



IRVINE UNIFIED SCHOOL DISTRICT

**Bid No. 2026/27-1FA
Lease of Relocatable Buildings**

**Bid Deadline/Opening:
May 13, 2026 at 11:00 am**

Contact: Tracy Franks
Facilities Planning Department
Irvine Unified School District
2015 Roosevelt, Irvine CA 92620
949-936-5318
Email: TracyFranks@iusd.org

Required Documents

****Please return this sheet with your bid documents****

Bid Documents Due at the Submission of the Due Date

- Bid Form
- Bid Form Pricing Sheet (all pages)
- D.I.R. Requirements for Contractors Working a Public Works Contract
- Bid Bond
- Designation of Subcontractors
- Equipment/Material Source Information
- Information Required of Bidder
- List of References
- Noncollusion Declaration
- Worker's Compensation Certificate
- Certification of Primary Participation Regarding Debarment, Suspension, and other Responsibility Matters
- Certification of Restriction on Lobbying

Other Forms not Required Until After Award

- Agreement
- Certificate of Liability Insurance, including an Additional Insured Endorsement, this is a separate document (Irvine must be named as an Additional Insured)
- Faithful Performance Bond
- Payment Bond
- Contractor's Certificate Regarding Non-Asbestos Containing Materials
- Certification of Participation of Disabled Veteran Business Enterprises
- Guarantee
- Drug-Free Workplace Certification
- Tobacco Use Policy
- Criminal Records Check Certification
- W-9

Table of Contents

NOTICE CALLING FOR BIDS
CALENDAR OF EVENTS
INFORMATION FOR BIDDERS
* BID FORM
* BID FORM PRICING SHEET
* D.I.R. REQUIREMENTS FOR CONTRACTORS WORKING IN A PUBLIC WORKS CONTRACT
* BID BOND FORM
* DESIGNATION OF SUBCONTRACTORS
* EQUIPMENT/MATERIAL SOURCE INFORMATION
* INFORMATION REQUIRED OF BIDDER
* NONCOLLUSION DECLARATION
* WORKER'S COMPENSATION CERTIFICATE
* CERTIFICATION OF PRIMARY PARTICIPANT REGARDING DEBARMENT,
SUSPENSION & OTHER RESPONSIBILITY MATTERS
* CERTIFICATE OF RESTRICTIONS LOBBYING
+ SAMPLE AGREEMENT
+ CERTIFICATE OF LIABILITY INSURANCE
+ FAITHFUL PERFORMANCE BOND
+ PAYMENT BOND
+ CONTRACTOR'S CERTIFICATE REGARDING NON-ASBESTOS CONTAINING
MATERIALS
+ DISABLED VETERAN BUSINESS ENTERPRISES (DVBE)
+ GUARANTEE
+ DRUG-FREE WORKPLACE CERTIFICATION
+ TOBACCO USE POLICY
+ NOTICE REGARDING CRIMINAL RECORDS CHECK
+ CRIMINAL RECORDS CHECK CERTIFICATION
+ W-9 FORM
CHANGE ORDER NO (ADDITIVE)
CHANGE ORDER NO (DEDUCTIVE)
GENERAL CONDITIONS
SPECIAL CONDITIONS
DRAWINGS

***IF THE ITEMS IDENTIFIED BY AN ASTERIK ARE NOT RETURNED AT THE TIME OF THE BID OPENING, THE BIDDER WILL BE DECLARED NON-RESPONSIVE.**

+ITEMS THAT SUCCESSFUL BIDDER MUST SUBMIT AFTER THE AWARD

NOTICE CALLING FOR BIDS

DISTRICT: IRVINE UNIFIED SCHOOL DISTRICT

BID DEADLINE: MAY 13, 2026 at 11:00 A.M.

PLACE OF RECEIPT: Irvine Unified School District
Facilities Planning Department
Attn: Tracy Franks
2015 Roosevelt, Building 7
Irvine, California 92620

NOTICE IS HEREBY GIVEN that the Irvine Unified School District of Orange County, California, acting by and through its Governing Board, hereinafter referred to as “District,” will receive up to, but not later than, the above-stated bid deadline, sealed bids at the place identified above for the award of a contracts for:

1. LEASE OF RELOCATABLE BUILDINGS, BID NO. 2026/27-1FA

2. PURCHASE OF RELOCATABLE & MODULAR BUILDINGS, BID NO. 2026/27-2FA

The DISTRICT is soliciting bids from qualified and experienced firms that can provide and install Division of State Architect (“DSA”) approved relocatable buildings in accordance with all requirements set forth in each bid identified above.

BID DOCUMENTS will be made available on **April 6, 2026** (as a download) at the following website: <https://iusd.org/business-services/facilities-planning-construction-services/bidder-information-public-notices> **Bidders will be responsible for reproducing all documents related to this bid.** All bids shall be made and presented on the forms provided in the bid documents.

Any request for information (RFI’s) regarding the interpretation of the bid documents must be received in writing, via e-mail, to TracyFranks@iusd.org **no later than 11:00 a.m. on April 21, 2026.**

In accordance with the provisions of Business and Professions Code Section 7028.15 and Public Contract Code Section 3300, the DISTRICT requires that the bidder possess a current Class **B** contractor’s license issued by the Contractors State License Board of the State of California, at the time the bid is submitted. Any bidder not so licensed at the time of the bid opening will be rejected as nonresponsive.

Bidders must meet the specified requirements regarding Disabled Veteran Business Enterprise (“DVBE”) Programs. Bidders may obtain information from the Office of Small Business & Disabled Veteran Business Enterprise Services (OSDS) at <http://www.dgs.ca.gov/pd/Programs/OSDS.aspx>.

It is each bidder’s sole responsibility to ensure its bid is timely delivered and received at the location designated as specified above. Any bid received at the designated location after the scheduled closing time for receipt of bids shall be returned to the bidder unopened.

Time is of the essence. The District reserves the right to reject any or all bids or to waive any irregularities or informalities in any bid or in the bidding process. The award of the Contract, if made by the District, will be by the action of the Governing Board. No bidder may withdraw any bid for a period of sixty (60) calendar days after the date set for the opening of the bids.

Irvine Unified School District
Governing Board

By: Tracy Franks
Supervisor, Facilities Purchasing

Advertise: OC Register
April 5, 2026 & April 12, 2026

CALENDAR OF EVENTS

EVENT	DETAILS	DATE
Bid Published	Orange County Register	April 5, 2026 April 12, 2026
Bid Posted	IUSD Website Facilities Planning & Construction Public Notice	April 6, 2026
Last Day to Submit Request for Information (RFI)/Questions	TracyFranks@iusd.org	on or before: 11:00 a.m. April 21, 2026
Issue Addendum in Response to RFI(s)	Upload to Website and E-Mail Participating Vendors	on or before: 11:00 a.m. April 24, 2026
Bid Opening/Deadline	Facilities Planning Department 2015 Roosevelt (Bldg. 7) Irvine, CA 92620	11:00 a.m. May 13, 2026
*Board of Education Action	Award of Contract	June 9, 2026

*Date is subject to change at the discretion of the District.

INFORMATION FOR BIDDERS

WARNING:

READ THIS DOCUMENT CAREFULLY.

**DO NOT ASSUME THAT IT IS THE SAME AS OTHER SIMILAR DOCUMENTS
YOU MAY HAVE SEEN, EVEN IF FROM THE SAME DISTRICT.**

1. Preparation of Bid Form. Bids shall be submitted on the prescribed Bid Form, Bid Form Pricing Sheet and completed in full. All bid items and statements shall be properly and legibly filled out. Numbers shall be stated both in words and in figures where so indicated, and where there is a conflict in the words and the figures, the words shall control over the numbers. The signatures of all persons shall be in longhand and in “blue” ink. Prices, wording and notations must be in ink or typewritten.

2. Form and Delivery of Bids. The bid must conform and be responsive to all bid documents and shall be made on the Bid Form and Bid Form Pricing Sheet provided, and the complete bid, together with any and all additional materials as required, shall be enclosed in a sealed envelope, addressed and hand delivered or mailed to **Irvine Unified School District, Facilities Planning Department, 2015 Roosevelt, Building 7, Irvine, CA 92620, Attn: Tracy Franks**, and must be received on or before the bid deadline (Public Contract Code Section 20112). The envelope shall be plainly marked in the upper left hand corner with the respondent's name, the proposal number and the date and time for the opening of proposals. **It is the bidder's sole responsibility to ensure that its bid is received prior to the bid deadline.** In accordance with Government Code Section 53068, any bid received after the scheduled closing time for receipt of bids shall be returned to the bidder unopened. At the time and place set forth for the opening of bids, the sealed bids will be opened and publicly read aloud.

3. Signature. Any signature required on bid documents must be signed in the name of the bidder and must bear the signature of the person or persons duly authorized to sign these documents. Where indicated, if bidder is a corporation, the legal name of the corporation shall first be set forth, together with two signatures: one from among the chairperson of the board, president or vice president and one from among the secretary, chief financial officer, or treasurer. Alternatively, the signature of other authorized officers or agents may be affixed, if duly authorized by the corporation. Such documents shall include the title of such signatories below the signature and shall bear the corporate seal. Where indicated, in the event that the bidder is a joint venture or partnership, there shall be submitted with the bid certifications signed by authorized officers of each of the parties to the joint venture or partnership, naming the individual who shall sign all necessary documents for the joint venture or partnership and, should the joint venture or partnership be the successful bidder, who shall act in all matters relative to the joint venture or partnership. If bidder is an individual, his/her signature shall be placed on such documents.

4. Modifications. Changes in or additions to any of the bid documents, alternative proposals, or any other modifications which are not specifically called for in the bid documents may result in the rejection of the bid as being nonresponsive. No oral, telephonic, facsimile or electronic modification of any of the bid documents will be considered.

5. Erasures, Inconsistent or Illegible Bids. The bid submitted must not contain any erasures, interlineations, or other corrections unless each such correction is authenticated by affixing the initials of the person(s) signing the bid in the margin immediately adjacent to the correction. In the event of inconsistency between words and numbers in the bid, words shall control numbers. In the event that any bid is unintelligible, illegible or ambiguous, the bid may be rejected as being nonresponsive.

6. Examination of Site and Bid Documents. At its own expense and prior to submitting its bid, each bidder shall examine all bid documents; visit the sites and determine the local conditions which may in any way affect the performance of the work; familiarize itself with all Federal, State and Local laws, ordinances, rules, regulations and codes affecting the performance of the work, including the cost of permits and licenses required for the work; determine the character, quality, and quantities of the work to be performed and the materials and equipment to be provided; and correlate its observations, investigations, and determinations with all requirements of the bid. The District shall not be liable for any loss sustained by the successful bidder resulting from any variance between the actual conditions and data given in the bid documents. Bidder agrees that the submission of bid shall be incontrovertible evidence that the bidder has complied with all the requirements of this provision of the Information for Bidders.

7. Withdrawal of Bids. Any bid may be withdrawn, either personally or by written request signed by the bidder, at any time prior to the scheduled closing time for receipt of bids. The bid security for a bid withdrawn prior to the scheduled closing time for receipt of bids, in accordance with this paragraph, shall be returned. No bidder may withdraw any bid for a period of sixty (60) calendar days after the date set for the opening of bids.

8. Interpretation of Project Documents. If any bidder is in doubt as to the true meaning of any part of the bid documents, or finds discrepancies in, or omissions from the bid documents, a written request for an interpretation or correction thereof must be submitted to Irvine Unified School District Supervisor of Facilities/Purchasing **within the timeframe stated in the Request for Information (RFI) deadline.** No requests shall be considered after this time. The bidder submitting the written request shall be responsible for its prompt delivery. Any interpretation or correction of the Project Documents will be made solely at DISTRICT's discretion and only by written addendum duly issued by the DISTRICT, and a copy of such addendum will be hand delivered or mailed or faxed to each bidder known to have received a set of the Project Documents. No person is authorized to make any oral interpretation of any provision in the Project Documents, nor shall any oral interpretation of Project Documents be binding on the DISTRICT. If there are discrepancies of any kind in the Project Documents, the interpretation of the DISTRICT shall prevail. **SUBMITTAL OF A BID WITHOUT A REQUEST FOR CLARIFICATIONS SHALL BE INCONTROVERTIBLE EVIDENCE THAT THE BIDDER HAS DETERMINED THAT THE PROJECT DOCUMENTS ARE ACCEPTABLE AND SUFFICIENT FOR BIDDING AND COMPLETING THE WORK; THAT BIDDER IS CAPABLE OF READING, FOLLOWING AND COMPLETING THE WORK IN ACCORDANCE WITH THE PROJECT DOCUMENTS; AND THAT BIDDER AGREES THAT THE PROJECT CAN AND WILL BE COMPLETED ACCORDING TO THE DISTRICT's TIMELINES AND ACCORDING TO THE PROGRESS SCHEDULE TO BE SUBMITTED BY THE SUCCESSFUL BIDDER INCORPORATING THE DISTRICT's TIMELINES FOR COMPLETION OF THE PROJECT.**

9. Bidders Interested in More Than One Bid. No person, firm or corporation shall be allowed to make, or file, or be interested in more than one bid for the same work unless alternate bids are specifically called for by the DISTRICT. A person, firm, or corporation that has submitted a subproposal to a bidder, or that has quoted prices of materials to a bidder, is not thereby disqualified from submitting a proposal or quoting prices to other bidders or submitting a bid on the Project.

10. Award of Contract. The DISTRICT reserves the right to reject any or all bids, or to waive any irregularities or informalities in any bids or in the bidding process. The award of the contract, if made by the DISTRICT, will be by action of the Governing Board and to the lowest responsive and responsible bidder. If two identical low bids are received from responsive and responsible bidders, the DISTRICT will determine which bid will be accepted pursuant to Public Contract Code Section 20117. In the event an award of the contract is made to a bidder, and such bidder fails or refuses to execute the Agreement and provide the required documents within five (5) working days after the notice of award of the contract to bidder, the DISTRICT may award the contract to the next lowest responsive and responsible bidder or reject all bidders. **The basis of award of contract will be on the base lease rate of the total of Line Item No. 1 through 12, cumulative totals of columns A, B, C, D, E, F, G, H and J only listed in the bid matrix.**

11. Alternate Bids. The Governing Board of the DISTRICT may call for alternate bids. Public Contract Code Section 20103.8. The Governing Board intends to award the contract to the lowest responsive and responsible bidder on the base bid without consideration of any of the additive and/or deductive items.

12. Agreement. The form of Agreement, which the successful bidder, as Contractor, will be required to execute, is included in the bid documents and should be carefully examined by the bidder. **The Agreement will be executed in two (2) original counterparts.** The complete Agreement consists of the following but not limited to the Notice Calling for Bids, Calendar of Events, Information For Bidders, Bid Form, Bid Form Pricing Sheet, D.I.R Requirements for Contractors Working in a Public Works Contract, Bid Bond Form, Designation of Subcontractors, Equipment/Material Source Information, Information Required of Bidders, Noncollusion Declaration, Worker's Compensation Certificate, Certification of Primary Participant Regarding Debarment, Suspension & Other Related Matters, Certificate of Lobbying, Sample Agreement, Certificate of Liability Insurance, Faithful Performance Bond, Payment Bond, Contractor's Certificate Regarding Non-Asbestos Containing Materials, Disable Veteran Business Enterprises (DVBE), Guarantee, Drug-Free Workplace Certification, Tobacco Use Policy, Notice Regarding Criminal Records Check, Criminal Records Check Certification, W-9 Form, Change Order NO (ADDITIVE), Change Order NO (DEDUCTIVE), General Conditions, Special Condition, Drawings, specifications, and all modifications, addenda and amendments, if any (hereinafter Bid Documents), thereof duly incorporated therein. All of above documents are intended to cooperate and be complementary so that any instructions or requirements called for in one and not mentioned in the other, or vice versa, are to be executed the same as if mentioned in all said documents. The intention of the documents is to include all labor, materials, equipment, transportation and services necessary for the proper delivery of all items called for in the Agreement.

13. Bonds. The Agreement, which the successful bidder will be required to execute, and the payment bond required in accordance with Civil Code Section 3247, are included in the Project Documents. The payment bond shall be in the amount not less than one hundred percent (100%) of the amount of the contract in accordance with Civil Code Section 3248. The successful bidder will

also be required to furnish a separate faithful performance bond in the amount of one hundred percent (100%) of the contract and in the form included in the Project Documents, which shall remain in full force and effect through the guarantee period as specified in the General Conditions. All bond premiums shall be at bidder's cost.

14. Competency of Bidders. In selecting the lowest responsive and responsible bidder, consideration will be given not only to the financial standing but also to the general competency of the bidder for the performance of the bid. By submitting a bid, each bidder agrees that the District, in determining the successful bidder and its eligibility for the award, may consider the bidder's experience and facilities, conduct and performance under other contracts, financial condition, reputation in the industry, and other factors, which could affect the bidder's performance of the contract. The District may also consider the qualifications and experience of persons and organizations proposed for those portions of the work. Operating costs, maintenance considerations, performance data and guarantees of materials and equipment may also be considered by the District. In this regard, the District may conduct such investigations as the District deems necessary to assist in the evaluation of any bid and to establish the responsibility, qualifications and financial ability of the bidder, proposed subcontractors, and other persons and organizations to do the work to the District's satisfaction within the prescribed time. The District reserves the right to reject the bid of any bidder who does not pass any such evaluation to the satisfaction of the District.

15. Designation of Subcontractors. Each bidder shall submit, on the form furnished with the Bid Documents, a list of the proposed subcontractors on this bid as required by the Subletting and Subcontracting Fair Practices Act (Public Contract Code Section 4100, et seq.). If alternate bids are called for and the bidder intends to use different or additional subcontractors, a separate list of subcontractors must be submitted for each such alternate bid. If the bidder fails to specify a subcontractor for any portion of the work in excess of one half (1/2) of one percent (1%) of the bidder's total bid, the bidder agrees that he/she is fully qualified to perform that work and agrees to perform that portion of the work. Violation of this requirement (including the procurement of a subcontractor for the Project if no subcontractor is specified) can result in the DISTRICT invoking the remedies of Public Contract Code Sections 4110 and 4111.

16. Insurance and Workers' Compensation. The successful bidder shall be required to furnish certificates and endorsements evidencing that the required insurance is in effect as set forth in the Agreement. District may request that such certificates and endorsements be completed on District provided forms. In accordance with the provisions of Section 3700 of the Labor Code, the successful bidder shall secure the payment of compensation to all employees. The successful bidder who has been awarded the contract shall sign and file with District prior to performing the work, the Workers' Compensation Certificate included as a part of the proposal documents. Labor Code section 1861.

a. Successful bidder shall, at bidder's sole cost and expense, maintain in full force and effect the following insurance coverages from a California licensed insurer with an A, VIII, or better rating from A.M. Best or an approved self-insurance program, sufficient to cover any claims, damages, liabilities, costs and expenses (including attorney fees) arising out of or in connection with bidder's fulfillment of the obligations under this bid:

i. Comprehensive General Liability Insurance, including bodily injury, property damage and contractual liability with minimum limits set by the DISTRICT. The policy may not contain an exclusion for sexual molestation or abuse coverage, may be waived by the District.

(a)	General Aggregate	\$2,000,000
(b)	Each Occurrence	\$1,000,000
(c)	Products/Completed Operations	\$1,000,000
(d)	Personal and Advertising Injury	\$1,000,000
(e)	Damage to Rented Premises	\$50,000
(f)	Medical Expense (any one person)	\$5,000

ii. Umbrella (excess) liability insurance coverage with a limit of \$3,000,000, unless waived by the DISTRICT. The policy may not contain an exclusion for sexual molestation or abuse coverage, may be waived by the District.

iii. Business Automobile Liability Insurance for owned, scheduled, non-owned, or hired automobiles with a combined single limit not less than \$1,000,000 per occurrence. (Required only if the bidder drives on behalf of the DISTRICT in the course of performing Services.)

iv. Professional Liability Insurance with a limit of \$1,000,000 per occurrence, unless waived by the DISTRICT and if applicable.

v. Workers' Compensation and Employers Liability Insurance in a form and amount covering bidder's full liability under the California Workers' Compensation Insurance and Safety Act and in accordance with applicable state and federal laws. The policy shall be endorsed with the insurer's waiver of rights of subrogation against the DISTRICT.

It should be expressly understood, however, that the coverage and limits referred to under i., ii., iii., and iv. above shall not in any way limit the liability of the bidder.

b. No later than five (5) days from execution of the Agreement by the DISTRICT and successful bidder, and prior to commencing the Services under this bid, bidder shall provide DISTRICT with certificates of insurance evidencing all coverages and endorsements required hereunder.

Successful bidder shall provide prior written notice to the DISTRICT thirty (30) days in advance of any non-renewal, cancellation, or modification of the required insurance. The certificates of insurance providing the coverages referred to in clauses i. and ii. above shall name DISTRICT, its Governing Board, officers, and employees, as additional insureds with appropriate endorsements. In addition, the certificates of insurance shall include a provision stating, "Such insurance as is afforded by this policy shall be primary, and any insurance carried by DISTRICT shall be excess and noncontributory." Failure to maintain the above-mentioned insurance coverages shall be cause for termination of the Agreement.

17. Contractor's License. If, at the time and date of the bid opening, bidder is not properly licensed to perform the Project in accordance with Division 3, Chapter 9, of the Business and Professions Code and the Project Documents, such bid will be rejected as nonresponsive. (Public Contract Code Section 3300) Pursuant to Business and Professions Code Section 7028.15, no payment shall be made for work or materials under the contract unless and until the Registrar of Contractors verifies to the DISTRICT that the bidder was properly licensed at the time the bid was submitted. Any bidder not so licensed is subject to penalties under the law and the contract will be considered void and DISTRICT shall have the right to bring an action against the unlicensed bidder awarded the contract for recovery of all compensation paid under the contract. (Business and Professions Code Section 7031(b) If the license classification specified hereinafter is that of a "specialty contractor" as defined in Section 7058 of the Business and Professions Code, the specialty contractor awarded the contract for this work shall construct a majority of the work, in accordance with the provisions of Business and Professions Code Section 7059. The bidder may not use the contractor license of a third party for this bid.

18. Anti-Discrimination. In connection with all work performed under this bid, there shall be no lawful discrimination against any prospective or active employee engaged in the work because of race, color, ancestry, national origin, religious creed, sex, age, marital status, physical disability, mental disability, or medical condition. The successful bidder agrees to comply with applicable Federal and State laws including, but not limited to, the California Fair Employment and Housing Act, beginning with Government Code Section 12900 and Labor Code Section 1735.

19. Hold Harmless/Indemnification and Insurance. The successful bidder awarded the contract will be required to defend, indemnify and hold harmless the District, the Governing Board, officers, agents, and employees and provide the required insurance as set forth in the Agreement.

20. Substitutions. Should the bidder wish to request any substitution for the materials, process, service, or equipment specified, the bidder shall be required to comply with Article 30 of the General Conditions.

21. Surety Qualifications for Bonds. Bidders shall ensure all surety companies have a minimum rating of "A-III," as rated by the current edition of Best's Key Rating Guide, published by A.M. Best Company, Oldwick, New Jersey 08858. Only California admitted surety insurers will be acceptable for the issuance of bonds. (Code of Civil Procedure Section 995.311) DISTRICT shall verify the status of the surety by one of the following ways: (1) printing out information from the website of the California Department of Insurance confirming the surety is an admitted surety insurer and attaching it to the bond, or (2) obtaining a certificate from the county clerk for the county in which the DISTRICT is located that confirms the surety is an admitted surety insurer and attaching it to the bond. Any admitted surety insurer who cannot satisfy the minimum rating specified above, but who satisfies the following requirements set forth in Code of Civil Procedure Section 995.660 shall be accepted and approved for the issuance of bonds:

(a) There must be on file in the office of the county clerk, for the county in which the DISTRICT is located, an unrevoked appointment, power of attorney, bylaws, or other instrument, duly certified by the proper authority and attested by the seal of the insurer authorizing the person who executed the bond to do so for and on behalf of the insurer within ten (10) calendar days of the

insurer's receipt of a request to submit such document from the DISTRICT, and an original or certified copy of the document must be submitted to the DISTRICT.

(b) A certified copy of the certificate of authority of the insurer issued by the Insurance Commissioner must be submitted to the DISTRICT within ten (10) calendar days of the insurer's receipt of a request to submit such document from the DISTRICT.

(c) A certificate from the clerk of the county that the certificate of authority of the insurer has not been surrendered, revoked, cancelled, annulled, or suspended, and in the event it has, whether renewed authority has been granted must be submitted to DISTRICT within ten (10) calendar days of the insurer's receipt of a request to submit such document from the DISTRICT.

(d) Copies of the insurer's most recent annual statement and quarterly statement filed with the California Department of Insurance must be submitted to the DISTRICT within ten (10) calendar days of the insurer's receipt of a request to submit the statements.

22. Liquidated Damages. All work must be completed within the time limits set forth in the Project Documents. It is agreed that damages for the failure to complete the Project described herein within the time limits required are impossible to ascertain. Should the work not be completed within the specified time for completion, the successful bidder awarded the contract shall be liable for liquidated damages, payable to the DISTRICT, in an amount identified in the Agreement for each calendar day of delay in completion. Such damages shall be deducted from any payments due or to become due to the successful bidder. Government Code Section 53069.85, Civil Code Section 1671. Damages for failure to provide required buildings within two weeks at a maximum shall result in a \$1000.00/day in liquidated damages.

23. Drug-Free Workplace Certification. Pursuant to Government Code Sections 8350, et seq., the successful bidder will be required to execute a Drug-Free Workplace Certification upon execution of the Agreement. The bidder will be required to take positive measures outlined in the certification in order to ensure the presence of a drug-free workplace. Failure to abide with the conditions set forth in the Drug-Free Workplace Act could result in penalties including termination of the Agreement or suspension of payment thereunder. The bidder will be required to take positive measures outlined in the certification in order to ensure the presence of a drug-free workplace. Failure to abide with the conditions set forth in the Drug-Free Workplace Act could result in penalties including termination of the Agreement or suspension of payment thereunder.

24. Noncollusion Declaration. In accordance with the provisions of Section 7106 of the Public Contract Code, each bid must be accompanied by a noncollusion declaration.

25. Change Orders. All change order requests must be submitted in the form set forth in the Project Documents and pursuant to Article 59 of the General Conditions. The amount of allowable charges submitted pursuant to a change order shall be limited to the charges allowed under Article 59 of the General Conditions. Indirect, consequential and incidental costs, project management costs, extended home office and field office overhead, administrative costs and profit and other charges not specifically authorized under Article 59 of the General Conditions will not be allowed.

26. Tobacco-Free Policy. The successful bidder shall agree to enforce a tobacco-free work site.

27. Criminal Records Check. The successful bidder will be required to comply with the applicable requirements of Education Code Section 45125.1 with respect to fingerprinting of employees and must complete the District's Criminal Records Check Certification.

28. Lead. Pursuant to the Lead-Safe Schools Protection Act (Education Code Sections 32240, et seq.) and other applicable law, the successful bidder shall not use lead-based paint, lead plumbing and solders, or other potential sources of lead contamination in the construction of any new school facility or the modernization or renovation of any existing school facility.

29. Disabled Veteran Business Enterprises. Each bidder must meet goals and requirements relating to three percent (3%) participation by Disabled Veteran Business Enterprises established by the DISTRICT, in accordance with the DISTRICT's policies and procedures. Bidders may obtain information from the Office of Small Business Certification and Resources (OSBCR) at <http://www.dgs.ca.gov/osbcr> or (916) 323-5478. The successful bidder shall be required to submit to the DISTRICT the DVBE Certification, which is included in the Bid Documents. Prior to, and as a condition precedent for final payment on the Project, the successful bidder shall provide appropriate documentation to the DISTRICT so that the DISTRICT can assess its success at meeting the DVBE participation goal.

30. Department of Industrial Relations (DIR) Registration - SB854. Per the California Department of Industrial Relations, no contractor or subcontractor may be awarded a contract for public work on a public works project, awarded on or after April 1, 2015, unless registered with the DIR pursuant to Labor Code section 1725.5. That would include a firm that subcontracts to perform services such as soils testing, surveying, and building/construction inspection, and anyone hired by the firm to perform those same services as an independent contractor. Please also note that Labor Code section 1725.5(a)(2)(A) requires workers' compensation coverage for any worker employed by a registered public works contractor unless that worker is separately registered with DIR as a public works contractor. For further information, please visit the DIR's website at <http://www.dir.ca.gov/Public-Works/SB854.html>.

31. State Public Works Enforcement. As required by Section 1773 of the California Labor Code, the California Department of Industrial Relations has determined the general prevailing rates of per diem wages for the locality in which the work is to be performed for the Project. Copies of these wage rate determinations, entitled Prevailing Wage Scale, are maintained at the Facilities Planning Department office located at 2015 Roosevelt, Irvine, CA 92620, and are available at the following website: www.dir.ca.gov. It shall be mandatory upon the successful bidder to whom the contract is awarded, and upon any subcontractor listed, to pay not less than the specified rates to all workers employed by them for the Project.

The successful bidder and any listed subcontractor(s) of this Project are subject to the oversight, monitoring and enforcement of prevailing wage requirements by the Department of Industrial Relations, Division of Labor Standards Enforcement, and will be required to submit certified payroll records to the Labor Commissioner.

No contractor or subcontractor may be listed on a bid proposal for a public works project (submitted on or after March 1, 2015) unless registered with the Department of Industrial Relations pursuant to Labor Code section 1725.5 [with limited exceptions from this requirement for bid purposes only under Labor Code section 1771.1(a)].

32. Project Phasing. The construction will start during the time period where school is in session, refer to the logistics plan for additional information. It is the contractor's responsibility to not impact the school's operation when delivering materials and accessing the dedicated construction area. Contractor is to avoid conflict with the school's start and finish times.

33. Bid Protest. Any bid protest must be in writing and received by the DISTRICT at the Facilities Planning Department office, 2015 Roosevelt, Irvine, CA 92620 before 5:00 p.m. no later than three (3) working days following the bid deadline and must comply with the following requirements:

- (a) Only a bidder who has actually submitted a Bid Proposal is able to submit a bid protest. Subcontractors are not eligible to submit bid protests. A bidder may not rely on the bid protest submitted by another bidder, but must timely pursue its own protest.
- (b) The bid protest must contain a complete written statement of the basis for the protest and all supporting documentation. Material submitted after the bid protest deadline will not be considered. The protest must refer to the specific portion(s) of the Bid Documents upon which the protest is based. The protest must include the name, address, and telephone number of the person representing the protesting bidder.
- (c) A copy of the bid protest and all supporting documents must also be transmitted in writing by the bid protest deadline to the bidder(s) that is/are the subject of the protest.
- (d) The bidder(s) that is/are the subject of the protest may submit a written response to the protest, provided the response is received by the DISTRICT before 5:00 p.m. no later than two (2) working days after the bid protest deadline or after receipt of the bid protest, whichever is sooner (the "Response Deadline"). The response must include all supporting documentation including the name, address, and telephone number of the person submitting the response. Material submitted after the Response Deadline will not be considered by the District.

The procedure and time limits set forth in this section are mandatory and are the protesting bidder's sole and exclusive remedy in the event of a bid protest. No exceptions to these time limits and procedures will be allowed and shall be strictly enforced by the District. Failure to comply with these procedures and time limits shall constitute a waiver of any right to further pursue a bid protest.

34. Term of Contract. The initial Contract Term will be for one (1) year and may be extended upon mutual consent of District and successful bidder for an additional four (4) one year periods in accordance with the provisions contained in the Education Code, Section 17596 (K-12). The maximum term of this Agreement is five (5) years.

35. Price Adjustment. The rates established in all schedules for Bid No. 2026/27-1FA shall be subject to adjustment once each year during the renewal period. Rate change request shall be provided in writing, to the District by May 1st of each year. On July 1st in each Agreement year, the rates will be adjusted upward or downward in an amount equal to the amount of the percentage change to the nearest one-tenth (1/10th) of a percent during the preceding twelve months in the Consumer Price Index (CPI) published by the Bureau of Labor Statistics, US Department of Labor, for the Los Angeles/Riverside/Orange County Area.

36. Debarment, Suspension, and Other Responsibility Matters. As required by Executive Order 12549, Debarment & Suspension, and implemented at 34 CFR Part 85, Bidder must certify that its principals are not presently debarred, suspended, proposed for debarment, declared ineligible, or voluntarily excluded from transactions with any federal department or agency. Submission of a signed bid in response to this solicitation is certification that Bidder is not currently debarred, suspended, proposed for debarment, declared ineligible, or voluntarily excluded from participation in this transaction by any state or federal department or agency. Submission is also agreement that Irvine Unified School District will be notified of any change in this status. Certification of Primary Participant regarding Debarment, Suspension, and other Responsibility Matters and Certification of Restriction on Lobbying must be completed and submitted at the time of the bid due date or the bidder may be declared as nonresponsive.

37. Lease Term. Due to the uncertainty of construction schedules and enrollment calculations, the DISTRICT may not be able to determine the exact lease term for which relocatable buildings will be needed once ordered. Further, once the buildings are ordered, delivered, and placed on a site, it is not financially practical to remove and replace them with newly leased buildings once the initial lease term has expired, if the buildings are still needed in the same location. The DISTRICT will determine the time frame that the buildings will be actually leased. The DISTRICT may extend or shorten the lease term as their need changes with the corresponding cost adjustments. As an example, the DISTRICT may believe it will need a relocatable building for 18 months. However, if the DISTRICT were to determine that the building is no longer needed at the 11-month milestone, an adjustment will be made, revising the lease term to eleven months with the corresponding cost adjustment. This will also apply to lease extensions.

The DISTRICT does not intend to execute the successful bidder's standard lease agreement or accept the terms and conditions in such agreement. Once the successful bidder is determined, the DISTRICT will negotiate a standard Lease Agreement with the successful bidder to be used for leases executed under the bid.

If the successful bidder has existing inventory in the DISTRICT, the DISTRICT has the option to utilize the existing inventory at the lease rate provided in the bid regardless of when the buildings were placed.

38. Lease Purchase Option. The DISTRICT will require bids for a lease/purchase of relocatable buildings. Bidders shall list the lump sum total cost of the leased/purchased relocatable building, including all financing, yearly payments, and buy-out expenses. There will be a \$1 buy-out/purchase option (at the DISTRICT's discretion) at the end of the lease term. Bidders shall submit the yearly payment schedule to support the \$1 Buy-Out/Lease Purchase Option listed on the bid matrix, item #5 and item #11.

CONTRACTOR NAME: _____

ADDRESS: _____

TELEPHONE: (____) _____ FAX: (____) _____

E-MAIL ADDRESS: _____

BID FORM AND REQUIRED DOCUMENTS ATTACHED HERETO

FOR

**LEASE OF RELOCATABLE BUILDINGS
BID NO. 2026/27-1FA**

FOR

**IRVINE UNIFIED SCHOOL DISTRICT
FACILITIES PLANNING DEPARTMENT
2015 ROOSEVELT, BUILDING 7
IRVINE, CA 92620**

BID FORM

Bidder Name: _____ **To: Irvine Unified School District, acting by and through the Governing Board herein, called the "District."**

1. The undersigned bidder, having become familiarized with all the following documents including but not limited to the Notice Calling for Bids, Calendar of Events, Information For Bidders, Bid Form, Bid Form Pricing Sheet, D.I.R Requirements for Contractors Working in a Public Works Contract, Bid Bond Form, Designation of Subcontractors, Equipment/Material Source Information, Information Required of Bidders, Noncollusion Declaration, Worker's Compensation Certificate, Certification of Primary Participant Regarding Debarment, Suspension & Other Related Matters, Certificate of Lobbying, Sample Agreement, Certificate of Liability Insurance, Faithful Performance Bond, Payment Bond, Contractor's Certificate Regarding Non-Asbestos Containing Materials, Disable Veteran Business Enterprises (DVBE), Guarantee, Drug-Free Workplace Certification, Tobacco Use Policy, Notice Regarding Criminal Records Check, Criminal Records Check Certification, W-9 Form, Change Order NO (ADDITIVE), Change Order NO (DEDUCTIVE), General Conditions, Special Condition, Drawings, specifications, and all modifications, addenda and amendments, if any (hereinafter Bid Documents), the local conditions affecting the performance of the work and the cost of the work at the place where the work is to be done, hereby proposes and agrees to be bound by all the terms and conditions of the Bid Documents and agrees to perform, within the time stipulated, the work, including all of its component parts, and everything required to be performed, and to provide and furnish and pay for any and all of the labor, materials, supplies, tools, equipment, and all applicable taxes, utility and transportation services necessary to perform the work and complete in a good workmanlike manner all of the work required in accordance with laws, codes, regulations, ordinances and any other legal requirements governing the work, in connection with the following:

**LEASE OF RELOCATABLE BUILDINGS
BID NO. 2026/27-1FA**

All in strict conformity with the Bid Documents, including Addenda Nos. ____, ____, ____, on file at the Facilities Planning Department office of the Irvine Unified School District for the sums as set forth in this Bid Form.

Each individual bid term shall be determined from reviewing the drawings and specifications and all portions of the Bid Documents, and shall include all items necessary to complete the work, including the assumption of all obligations, duties, and responsibilities necessary to the successful completion of the work, and the furnishing of all materials and equipment required to be incorporated in and form a permanent part of the work, and the furnishing of tools, equipment, supplies, transportation,

facilities, labor, superintendence, and services required to perform and complete the work, all as per the requirements of the Bid Documents, whether or not expressly listed or designated.

1. It is understood that the District reserves the right to reject any or all bids or to waive any irregularities or informalities in any bids or in the bidding process. Bidder agrees that this bid shall remain open and not be withdrawn for the period specified in the Information for Bidders.

2. The required list(s) of proposed subcontractors is attached hereto, and the undersigned represents and warrants that such list(s) is complete and in compliance with the Subletting and Subcontracting Fair Practices Act. Public Contract Code Sections 4100, et seq.

3. It is understood and agreed that if written notice of the award of a contract is mailed, faxed, or delivered to the bidder, the bidder will execute and deliver to the DISTRICT the Agreement and will also furnish and deliver to the DISTRICT the Faithful Performance Bond and a separate Payment Bond as specified, and certificates and endorsements of insurance, the Workers' Compensation Certificate, Drug-Free Work Place Certification, the Criminal Records Check Certification, Contractor's Certificate Regarding Non-Asbestos Containing Materials, and the Disabled Veteran Business Enterprises Certification, if applicable, within five (5) working days of the notice of award of the contract, or as otherwise requested in writing by the DISTRICT. It is understood that should bidder fail or refuse to return these documents as required by the DISTRICT, the bid security shall be forfeited to the DISTRICT. The bidder further agrees that the work shall be commenced by the bidder, if awarded the contract, on or before the fifth (5th) day after receiving the DISTRICT's Notice to Proceed, and shall be completed by the bidder in the time specified by the DISTRICT.

4. Communication conveying notice of award of the contract, requests for additional information or other correspondence should be addressed to the bidder stated below in Section 6.

5. The name(s) of all persons interested in the bid as principals are as follows:

<u>Name</u>	<u>Address</u>	<u>Phone/ Email</u>

6. In submitting this bid, the bidder offers and agrees that if the bid is accepted, it will assign to the DISTRICT all rights, title and interest in and to all causes of action it may have under Section 4 of the Clayton Act (15 U.S.C. Section 15) or under the Cartwright Act (Business & Professions Code Section 16700, et seq.) arising from purchases of goods, materials, or services by the bidder for sale to the DISTRICT pursuant to the bid. Such assignment shall be made and become effective at the time the DISTRICT tenders final payment under the contract. (Public Contract Code Section 7103.5; Government Code Section 4450, 4451 and 4552).

7. The undersigned hereby warrants that the bidder has all appropriate licenses, **License No.** _____, Class ____, at the time of the bid opening, that such licenses entitles bidder to provide the work, which such license will be in full force and effect throughout the duration of performance of this Project. Bidder shall be nonresponsive if the Bidder is not licensed as required by the DISTRICT at the time of the bid opening. Any and all subcontractors to be employed by the undersigned shall have appropriate licenses at the time of the bid opening.
8. The bidder hereby certifies that it is, and at all times during the performance of work hereunder shall be, in full compliance with the provisions of the Immigration Reform and Control Act of 1986 ("IRCA") in the hiring of its employees, and the bidder shall indemnify, hold harmless and defend the DISTRICT against any and all actions, proceedings, penalties or claims arising out of the bidder's failure to comply strictly with the IRCA.
9. It is understood and agreed that if requested by the DISTRICT, the bidder shall furnish a notarized financial statement, references, and other information required by the DISTRICT that is sufficiently comprehensive to permit an appraisal of bidder's ability to perform the work.
10. The undersigned hereby warrants that all work shall be completed within the calendar day timeframes set forth per Special Conditions and all other Contract Documents. Time is of the essence. The undersigned agrees that failure to complete the work within the time set forth herein will result in the imposition of liquidated damages, payable to the District, in an amount set forth in the Agreement for each consecutive calendar day of delay (Government Code Section 53069.85).
11. **Time is of the essence.**
12. The required Noncollusion Declaration is attached as required by Public Contract Code Section 7106. Bidder understands and agrees that failure to submit a completed and signed declaration will render the bidder automatically nonresponsive.
13. It is understood and agreed that all change order requests must be submitted in the form set forth in the Project Documents and pursuant to Article 59 of the General Conditions. The amount of allowable charges submitted pursuant to a change order shall be limited to the charges allowed under Article 59 of the General Conditions. Indirect, consequential and incidental costs, project management costs, extended home office and field office overhead, administrative costs and profit and other charges not specifically authorized under Article 59 of the General Conditions will not be allowed.
14. Failure to complete the Bid Form and Bid Form Pricing Sheet in its entirety will render a bidder nonresponsive.
15. Pursuant to Public Contract Code Sections 20118 and 20652, other public agencies in the State of California may procure identical items off this bid under the same terms and conditions. Public agencies in the State of California shall process their purchase orders and warrants directly to the successful bidder upon agreement by their District and the

successful bidder. Acceptance or rejection of this clause will not affect the outcome of this bid.

OPTION GRANTED: _____

OPTION NOT GRANTED: _____

**(Complete the Bid Pricing Sheets Attached Hereto)
Must be Included with Bid**

This Form Must be Submitted with Bid

ITEM		A 24' X 40' Classroom	B 36' X 40' Classroom	C 48' X 40' Classroom	D 12' X 40' Restroom (2 Door)	E 12' X 40' Restroom (3 Door)	F 12' X 40' Restroom (4 Door)	G 36' X 40' Science Classroom	H 24' X 40' Daycare w/Restroom	J 48' X 40' Daycare w/Restrooms
BASE LEASE RATE - 3 YEARS										
1	ANNUAL PAYMENT									
2	LUMP SUM PURCHASE AFTER 3 YR LEASE									
3	DELIVERY & SET-UP COSTS									
4	REMOVAL COSTS									
5	\$1 BUY-OUT/LEASE PURCHASE OPTION AFTER 3 YEAR LEASE									
6	EARLY TERMINATION FEE									

ITEM		A 24' X 40' Classroom	B 36' X 40' Classroom	C 48' X 40' Classroom	D 12' X 40' Restroom (2 Door)	E 12' X 40' Restroom (3 Door)	F 12' X 40' Restroom (4 Door)	G 36' X 40' Science Classroom	H 24' X 40' Daycare w/Restroom	J 48' X 40' Daycare w/Restrooms
BASE LEASE RATE - 5 YEARS										
7	ANNUAL PAYMENT									
8	LUMP SUM PURCHASE AFTER 5 YR LEASE									
9	DELIVERY & SET-UP COSTS									
10	REMOVAL COSTS									
11	\$1 BUY-OUT/LEASE PURCHASE OPTION AFTER 5 YEAR LEASE									
12	EARLY TERMINATION FEE									
1 THRU 12 CUMULATIVE TOTAL:										

NOTE: LEASED RELOCATABLE(S) TO BE BUILT NO LATER THAN 2011. ALL FINISHES TO BE IN GOOD WORKING CONDITION; SUBJECT TO DISTRICT REVIEW AND APPROVAL PRIOR TO SIGN-OFF.

Add Lines 1 thru 12, TOTAL OF ALL COLUMNS:

\$

**LEASE OF RELOCATABLE BUILDINGS
 BID PRICING SHEET - ADDITIVES**

ITEM #	ADDITIVES	UNIT	PRICE
1	Carpet upgrade Bentley	SY	
2	100 Lb. stiffened floor	N/A	
3	150 Lb. foundation system	N/A	
4	70 Lb. stiffened floor	N/A	
5	Additional metal ramp and landing with handrails	EA	
6	Cost per linear foot to extend metal ramp or landing and handrails	LF	
7	Interior non-rated 2x4 wall 16" OC from floor to roof	LF	
8	Interior gender neutral toilet room	EA	
9	Plumbed ADA sink and cabinet - 4 lf	EA	
10	10 gallon electric water heater	EA	
11	Instant flow tankless electric water heater	EA	
13	Drinking fountain interior wall mounted	EA	
14	Dual drinking fountain exterior wall mounted	EA	
15	Add for custom exterior colors for each module	EA	
16	Base cabinet - WIC #102 - 36L x 84H x 24D	EA	
17	Open upper cabinet - WIC #300 - 36L x 30H x 12D	EA	
18	Upper cabinet & doors - WIC #302 - 36L x 30H x 12D	EA	
19	Open tall storage cabinet - WIC #400 - 36L x 84H x 24D	EA	
20	Lockable tall storage cabinet - WIC #402 - 36L x 84H x 24D	EA	
21	Tall teacher cabinet - WIC #530 - 48L x 84H x 24D	EA	
22	Cubby storage - WIC #544 - 48L x 66H x 12D (48 cubicles)	EA	
23	Low book shelves - WIC #600 - 36L x 42H x 9d	EA	
24	Teaching wall (see drawings)	EA	
25	Science work station	EA	
26	8' x 4' XOX sliding aluminum window - 46% dual glazed	EA	
27	4' x 4' XO sliding aluminum window - 46% dual glazed	EA	

LEASE OF RELOCATABLE BUILDINGS
BID PRICING SHEET - ADDITIVES

ITEM #	ADDITIVES	UNIT	PRICE
28	Ceramic tile with thin set over ½" backing	SF	
29	Exterior door package (metal) - 3070	EA	
30	Wall 110v duplex receptacle with cover	EA	
31	Recessed duplex 110v floor receptacle with cover	EA	
32	Wall data outlet with ½" conduit stubbed into attic cavity	EA	
33	Signal termination box 6" x 6" x 6" with ¾" conduit stubbed above ceiling	EA	
34	200 amp panel – single phase	EA	
35	400 amp panel – single phase	EA	
36	220v – 30 amp circuit outlet	EA	
37	Dedicated computer circuit – 20 amp	EA	
38	Interior light switch	EA	
39	Exit light (high) with battery backup (wall mount)	EA	
40	Operable wall – Modernfold 900 Series floor supported 8'6" high STC 45	LF	
41	Add 3-1/2 ton wall mount HVAC unit	EA	
42	Add 4 ton wall mount HVAC unit	EA	
43	Add 5 ton wall mount HVAC unit	EA	
44	Add 3-1/2 ton wall mount HVAC unit – three phases	EA	
45	Add 4 ton wall mount HVAC unit – three phases	EA	
46	Add 5 ton wall mount HVAC unit – three phases	EA	
47	HVAC return chase wall	EA	
48	Supply register and 12' of ducting	EA	
49	Return register and 12' of ducting	EA	
50	4" building separations 9 includes front & rear metal close off and roof cap	EA	
51	Two foot (2') wood close off between building	EA	
52	Eye wash station with science sink	EA	
53	Mop sink – 28"x 28"	EA	
54	Exterior fluorescent light fixture	EA	

**LEASE OF RELOCATABLE BUILDINGS
BID PRICING SHEET - ADDITIVES**

ITEM #	ADDITIVES	UNIT	PRICE
55	12' X 40' Building Relocation	EA	
56	24' X 40' Building Relocation	EA	
57	Additional 12' x 40' Modules Relocation (Add to 24' x 40')	EA	
58	Acid proof epoxy science classroom counters	LF	
59	Acid proof epoxy science classroom sink with goose neck faucet	EA	
60	Science classroom gas turret	EA	
61	Add epoxy floor finish	SF	
62	Upgrade exterior wall to one (1) hour rated	SF	
63	Upgrade exterior wall to two (2) hour rated	SF	
64	Double exterior door with mullion and panic hardware	EA	
65	Floor drain – Zurn with trap primer	EA	
66	Water closet – Adult/Child HDC with grab bar	EA	
67	Urinal with flush valve	EA	
68	Lavatory sink	EA	
69	Shower HDC fiberglass	EA	
70	Vinyl composition tile (VCT)	SF	
71	Sheet vinyl floor	SF	
72	Wall mounted TV Brackets	EA	
73	Occupancy sensors	EA	
74	Gas piping (as relates to a science classroom)	LF	
75	Acid waste piping (as relates to a science classroom)	LF	
76	Armstrong 1 hour fire rated ceiling system	SF	
77	3 Ft Wide window (dual glaze) with wire glass	EA	
78	4 Ton single phase heat pump – 13 seer	EA	
79	Interior walls with sound insulation	SF	
80	Additional transportation rate beyond 100 miles up to 40' module, per 25 miles increments up to 200+miles	MILE	
81	Engineering and Design (per hour)	HR	

LEASE OF RELOCATABLE BUILDINGS
BID PRICING SHEET - ADDITIVES

ITEM #	ADDITIVES	UNIT	PRICE
82	Craning and rigging (four hour minimum) (per hour)	HR	
83	Equipment charges (minimum of 8 hours)	HR	
84	On-site prevailing wage labor rate (per hour)	HR	
85	Carpet Cleaning (per hour)	HR	
86	Final Cleaning (per hour)	HR	
87	Tack Panel 4' x 8' (each)	EA	
88	New Wood Foundation & Skirting Labor and Material (24' x 40' Classroom)	EA	
89	Labor and Material Rolling of Building (24' x 40' Classroom)	EA	
90	Interior/Exterior Touch-up Paint Labor and Material (per SF)	SF	

- End of Bid Pricing Sheets -

The undersigned hereby declares that all of the representatives of this bid are made under penalty of perjury under the laws of the State of California.

Individual Name: _____
Signed by: _____
Print Name: _____
Date: _____
Business Address: _____
Telephone: _____

Partnership Name: _____
Signed by: _____
Print Name: _____
Date: _____
Business Address: _____
Telephone: _____
Other Partner(s): _____

Corporation Name: _____
(a _____ Corporation)
Business Address: _____
Telephone _____
Signed by: _____, President Date: _____
Print Name: _____, President Date: _____
Signed by: _____, Secretary Date: _____
Print Name: _____, Secretary Date: _____

_____ !A corporation awarded the contract shall furnish evidence of its corporate existence and evidence that the officer signing the Agreement and bonds is duly authorized to do so.

Joint Venturer Name: _____

Signed by: _____

Print Name: _____

Date: _____

Business Address: _____

Telephone: _____

Other Parties *If an individual* Name: _____
to Joint Venturer

Signed by: _____

Print Name: _____

Date: _____

Doing Business as: _____

Business Address: _____

Telephone: _____

If a Partnership Name: _____

Signed by: _____

Print Name: _____

Date: _____

Business Address: _____

Telephone: _____

If a Corporation Name: _____
(a _____ Corporation)

Signed by: _____

Print Name: _____

Title: _____

Date: _____

Business Address: _____

Telephone: _____

**D.I.R. REQUIREMENTS FOR CONTRACTORS WORKING
ON A PUBLIC WORKS PROJECT**

Per the California Department of Industrial Relations, no contractor or subcontractor may be awarded a contract for public work on a public works project, awarded on or after April 1, 2015, unless registered with the DIR pursuant to Labor Code section 1725.5. That would include a firm that subcontracts to perform services such as soils testing, surveying, and building/construction inspection, and anyone hired by the firm to perform those same services as an independent contractor. Please also note that Labor Code section 1725.5(a)(2)(A) requires workers' compensation coverage for any worker employed by a registered public works contractor unless that worker is separately registered with DIR as a public works contractor.

The link below is provided to find information on how to register.

<http://www.dir.ca.gov/public-works/publicworks.html>

In addition, on all projects awarded on or after April 1, 2015, contractors and subcontractors, with a DIR classification, must furnish electronic certified payroll records (eCPR) to the Labor Commissioner in PDF format. eCPR registration is at <https://apps.dir.ca.gov/eCPR/DAS/altlogin> is required. Contractors and subcontractors must also supply the awarding agency with copies of certified payrolls.

Company Name: _____

DIR Registration Number: _____

California State Contractor's License Number: _____

Bid Bond No.: _____

BID BOND

KNOW ALL PERSONS BY THESE PRESENT, that we _____, as Principal, and _____, as Surety, a California admitted surety insurer, are held and firmly bound unto the **Irvine Unified School District**, hereinafter called the DISTRICT, in the sum of Ten Percent (10%) OF THE TOTAL AMOUNT OF THE BID of the Principal submitted to the said DISTRICT for the work described below for the payment of which sum in lawful money of the United States, well and truly to be made, we jointly and severally bind ourselves, our heirs, executors, administrators, successors and assigns.

The condition of this obligation is such that whereas the Principal has submitted the accompanying bid dated _____, 20____, for the **Lease of Relocatable Buildings, Bid No. 2026/27-1FA**.

NOW, THEREFORE, if the Principal shall not withdraw said bid within the period specified therein after the opening of the same, or, if no period be specified, within sixty (60) days after said opening; and if the Principal is awarded the contract, and shall within the period specified therefore, or, if no period be specified, within five (5) working days after the notice of award of the contract, or as otherwise requested in writing by the DISTRICT, enter into a written contract with the DISTRICT, in accordance with the bid as accepted and give bonds with good and sufficient surety or sureties, as may be required for the faithful performance and proper fulfillment of such contract and for the payment for labor and materials used for the performance of the contract, furnish certificates and endorsements evidencing the required insurance is in effect and furnish and deliver to the DISTRICT the Workers' Compensation Certificate, Drug-Free Work Place Certification, the Criminal Records Check Certification, Contractor's Certificate Regarding Non-Asbestos Containing Materials, and the Disabled Veteran Business Enterprises Certification, if applicable, then the above obligation shall be void and of no effect, otherwise the bond amount shall be forfeited to the DISTRICT.

Surety, for value received, hereby stipulates and agrees that no change, extension of time, alteration or addition to the terms of the contract or the call for bids, or to the work to be performed thereunder, or the specifications accompanying the same, shall in any way affect its obligation under this bond, and it does hereby waive notice of any such change, extension of time, alteration or addition to the terms of said contract or the call for bids, or to the work, or to the specifications

In the event suit is brought upon this bond by the DISTRICT and judgment is recovered, the Surety shall pay all costs incurred by the DISTRICT in such suit, including reasonable attorney's fees to be fixed by the court.

IN WITNESS HEREOF, the parties have executed this bond under their several seals this _____ day of _____, 20____, the name and corporate seal of each corporate party being hereto affixed and duly signed by its undersigned authorized representative.

(Corporate Seal of
Principal, if
Corporation)

Principal (Proper Name of Bidder)

By: _____
Signature

Print Name

Title

(Corporate Seal
of Surety)

Surety

(Attach Attorney-in-Fact Certificate
and Required Acknowledgements)

By: _____
Signature

Print Name

Title

Address

Telephone No.

Facsimile No.

DESIGNATION OF SUBCONTRACTORS

In compliance with the Subletting and Subcontracting Fair Practices Act (Public Contract Code Section 4100 et. seq.) and any amendments thereof, each bidder shall set forth below: (a) the name and the location of the place of business of each subcontractor who will perform work or labor or render service to the bidder (prime contractor) in or about the construction of the work or improvement to be performed under this contract or a subcontractor licensed by the State of California who, under subcontract to the bidder (prime contractor), specially fabricates and installs a portion of the work or improvement according to detailed drawings contained in the plans and specifications in an amount in excess of one-half of one percent of the bidder's (prime contractor's) total bid and (b) the portion of the work which will be done by each subcontractor. The bidder (prime contractor) shall list only one subcontractor for each such portion as is defined by the bidder (prime contractor) in this bid.

If a bidder (prime contractor) fails to specify a subcontractor or if a bidder (prime contractor) specifies more than one subcontractor for the same portion of work to be performed under the contract in excess of one-half of one percent of the bidder's (prime contractor's) total bid, bidder shall be deemed to have agreed that bidder is fully qualified to perform that portion, and that bidder alone shall perform that portion. Violation of this requirement (including the procurement of a subcontractor for the Project if no subcontractor is specified) can result in the DISTRICT invoking the remedies of Public Contract Code Sections 4110 and 4111.

No bidder (prime contractor) whose bid is accepted shall (a) substitute any subcontractor, (b) permit any subcontractor to be voluntarily assigned or transferred or allow it to be performed by anyone other than the original subcontractor listed in the original bid, or (c) sublet or subcontract any portion of the work in excess of one-half of one percent of the bidder's (prime contractor's) total bid as to which the original bid did not designate a subcontractor, except as authorized in the Subletting and Subcontracting Fair Practices Act. Subletting or subcontracting of any portion of the work in excess of one-half of one percent of the bidder's (prime contractor's) total bid as to which no subcontractor was designated in the original bid shall only be permitted in cases of public emergency or necessity, only after a finding reduced to writing as a public record of the DISTRICT awarding this contract setting forth the facts constituting the emergency or necessity.

Note: If alternate bids are called for and bidder intends to use different or additional subcontractors on the alternates, a separate list of subcontractors must be provided for each such alternate. Identify additional list of subcontractors by Alternate Bid No.

_____.

DESIGNATIONS OF SUBCONTRACTORS FORM

Type of Trade, Labor or Service	Subcontractor Name & License #, License Expiration Date (indicate if a DVBE participant)	Complete Physical Address (in its entirety) and Telephone No.
1.	_____ License # _____ DVBE: Y or N (circle one)	_____ _____ Telephone: _____
2.	_____ License # _____ DVBE: Y or N (circle one)	_____ _____ Telephone: _____
3.	_____ License # _____ DVBE: Y or N (circle one)	_____ _____ Telephone: _____
4.	_____ License # _____ DVBE: Y or N (circle one)	_____ _____ Telephone: _____
5.	_____ License # _____ DVBE: Y or N (circle one)	_____ _____ Telephone: _____

Bidder agrees that within twenty-four (24) hours of the bid opening, Bidder shall provide the DISTRICT with the license number (if applicable), expiration date of license, complete address and telephone numbers of each listed subcontractor if such information is not available at the time of the bid opening.

Dated: _____

_____ Name of Bidder

By: _____
(Signature of Bidder)

Print Name: _____

Address: _____

Telephone: _____

EQUIPMENT/MATERIAL SOURCE INFORMATION

The name of the manufacturer of each piece of equipment that will be installed in this work shall be set forth below. Only one manufacturer of each piece of equipment shall be listed. Bidder agrees that in the event any listed manufacturer is not specifically named in the Bid Documents, it will, prior to award, submit complete information satisfactory to the Architect that such manufacturer's equipment complies with all requirements of the Bid Documents. If, in the opinion of the Architect, the listed manufacturer's equipment does not comply with the Bid Documents, the bid may be rejected unless, prior to award, the bidder agrees in writing to supply approved equipment without a change in the bid price.

<u>Equipment/Material</u>	<u>Manufacturer</u>
_____	_____
_____	_____
_____	_____
_____	_____
_____	_____
_____	_____
_____	_____
_____	_____
_____	_____
_____	_____

INFORMATION REQUIRED OF BIDDER

The Bidder shall furnish all the following information. Bidder shall carefully read and answer all questions to ensure completeness and accuracy. Failure to comply with this requirement may cause rejection of the bid. Additional sheets may be attached if necessary. "You" or "your" as used herein refers to the bidder and any of its owners, officers, directors, shareholders, principals, responsible managing officer (RMO) or responsible managing employee (RME). DISTRICT has discretion to request additional information.

- (1) Bidder name and address (Post Office Box Number not sufficient):

- (2) Telephone: _____ Fax No.: _____
Electronic Mail: _____

- (3) Individual ___ Partnership ___ Corporation ___ Joint Venture ___ (check one)

- (4) Bidder's License No. _____ Class: _____
License Expiration Date _____
Name of License holder _____

- (5) Have you ever been licensed under a different name or different license number?
Yes ___ No ___ if "Yes," give name and license number.

- (6) Names and titles of all your owners, officers, principals, responsible managing officers and responsible managing employees:

Name	Title
_____	_____
_____	_____
_____	_____

- (7) Number of years in this type of work: _____

- (8) Person who inspected work site: _____
Name and Title: _____
Date of Inspection: _____

- (9) How many years of experience have you had in this type of work specific to schools? _____

- (10) How many years of experience have you had in this type of work? _____

(11) Have you ever been terminated from a school or public project prior to the completion of the project? Yes ___ No ___ if the answer is "Yes," give dates, names and addresses of school/public agency and details.

(12) Have you ever been barred from bidding on any school or public project? Yes ___ No ___ if the answer is "Yes," give dates, names and addresses of school/public agency and details.

(13) Have you ever defaulted on any school or public project that resulted in a claim to a surety? Yes ___ No ___ if the answer is "Yes," give dates, names and addresses of school/public agency and details. _____

(14) Have you been assessed damages (i.e., liquidated damages) for any public project in the past ten (10) years? Yes ___ No ___ if the answer is "Yes," give dates, names, and addresses of public agency and details. _____

(15) Have you ever brought any claim(s) against a public agency? Yes ___ No ___ if the answer is "Yes," please explain in detail name of public agency, nature of the claim and outcome.

(16) Have you ever failed to complete a school or public project in the last ten (10) years? Yes ___ No ___ if the answer is "Yes," provide name of public agency and details:

(17) Have you been in litigation, arbitration, or dispute of any kind on a question or questions relating to a public project during the past ten (10) years? Yes ___ No ___ If the answer is "Yes," provide name of public agency and details. _____

(18) List the names, addresses and telephone numbers of three Architects or Engineers whose jobs you have worked on in the past five (5) years.

<u>Name</u>	<u>Address</u>	<u>Telephone</u>
_____	_____ - _____	() _____
_____	_____	() _____
_____	_____	() _____

(19) Do you now or have you ever had any direct or indirect business, financial or other connection with any officer, employee or consultant of the DISTRICT or Architect?
Yes ___ No ___ if so, please elaborate.

(20) List at least five (5) of your most recent school projects.

- (1) _____
- (2) _____
- (3) _____
- (4) _____
- (5) _____

(21) Are you currently under contract for another project? Yes ___ No ___ if the answer is "Yes," please provide the following information:

(a) Project Number 1:

Name of Project: _____

Detailed Description: _____

Name of Project Owner: _____

Contract Amount: _____

Completion Date: _____

(b) Project Number 2:

Name of Project: _____

Detailed Description: _____

Name of Project Owner: _____

Contract Amount: _____

Completion Date: _____

(c) Project Number 3:

Name of Project: _____

Detailed Description: _____

Name of Project Owner: _____

Contract Amount: _____

Completion Date: _____

(d) Project Number 4:

Name of Project: _____

Detailed Description: _____

Name of Project Owner: _____

Contract Amount: _____

Completion Date: _____

(e) Project Number 5:

Name of Project: _____

Detailed Description: _____

Name of Project Owner: _____

Contract Amount: _____

Completion Date: _____

(22) Are there projects not listed above that will be undertaken during the duration of DISTRICT's Project? Yes ___ No ___ if the answer is "Yes," please provide the following information:

(a) Project Number 1:

Name of Project: _____

Detailed Description: _____

Name of Project Owner: _____

Contract Amount: _____

Completion Date: _____

(b) Project Number 2:

Name of Project: _____

Detailed Description: _____

Name of Project Owner: _____

Contract Amount: _____

Completion Date: _____

(c) Project Number 3:

Name of Project: _____

Detailed Description: _____

Name of Project Owner: _____

Contract Amount: _____

Completion Date: _____

(d) Project Number 4:

Name of Project: _____

Detailed Description: _____

Name of Project Owner: _____

Contract Amount: _____

Completion Date: _____

(e) Project Number 5:

Name of Project: _____

Detailed Description: _____

Name of Project Owner: _____

Contract Amount: _____

Completion Date: _____

LIST OF REFERENCES

Please provide references of school districts and/or any public agencies that bidder has contracted with to provide Lease of Relocatable Buildings.

1. Firm Name:	
Address:	
Telephone Number:	
Contact Person:	
Description of work:	

2. Firm Name:	
Address:	
Telephone Number:	
Contact Person:	
Description of work:	

3. Firm Name:	
Address:	
Telephone Number:	
Contact Person:	
Description of work:	

4. Firm Name:	
Address:	
Telephone Number:	
Contact Person:	
Description of work:	

**NONCOLLUSION DECLARATION TO BE EXECUTED BY
BIDDER AND SUBMITTED WITH BID**
(Public Contract Cod Section 7106)

The undersigned declares:

I am the _____ [Title] of _____ [Name of Company], the party making the foregoing bid.

The bid is not made in the interest of, or on behalf of, any undisclosed person, partnership, company, association, organization, or corporation. The bid is genuine and not collusive or sham. The bidder has not directly or indirectly induced or solicited any other bidder to put in a false or sham bid. The bidder has not directly or indirectly colluded, conspired, connived, or agreed with any bidder or anyone else to put in a sham bid, or to refrain from bidding. The bidder has not in any manner, directly or indirectly, sought by agreement, communication, or conference with anyone to fix the bid price of the bidder or any other bidder, or to fix any overhead, profit, or cost element of the bid price, or of that of any other bidder. All statements contained in the bid are true. The bidder has not, directly or indirectly, submitted his or her bid price or any breakdown thereof, or the contents thereof, or divulged information or data relative thereto, to any corporation, partnership, company, association, organization, bid depository, or to any member or agent thereof, to effectuate a collusive or sham bid, and has not paid, and will not pay, any person or entity for such purpose.

Any person executing this declaration on behalf of a bidder that is a corporation, partnership, joint venture, limited liability company, limited liability partnership, or any other entity, hereby represents that he or she has full power to execute, and does execute, this declaration on behalf of the bidder.

I declare under penalty of perjury under the laws of the State of California that the foregoing is true and correct and that this declaration is executed on _____ [Date], at _____ [City], _____ [State].

Signature

Print Name

WORKER'S COMPENSATION CERTIFICATE

Labor Code section 3700.

"Every employer except the state shall secure the payment of compensation in one or more of the following ways:

- (a) By being insured against liability to pay compensation in one or more insurers duly authorized to write compensation insurance in this state.
- (b) By securing from the Director of Industrial Relations a certificate of consent to self-insure either as an individual employer or as one employer in a group of employers, which may be given upon furnishing proof satisfactory to the Director of Industrial Relations of ability to self-insure and to pay any compensation that may become due to his or her employees.
- (c) For any county, city, city and county, municipal corporation, public district, public agency or any political subdivision of the state, including each member of a pooling arrangement under a joint exercise of powers agreement (but not the state itself), by securing from the Director of Industrial Relations a certificate of consent to self-insure against workers' compensation claims, which certificate may be given upon furnishing proof satisfactory to the director of ability to administer workers' compensation claims properly, and to pay workers' compensation claims that may become due to its employees. On or before March 31, 1979, a political subdivision of the state, which, on December 31, 1978, was uninsured for its liability to pay compensation, shall file a properly completed and executed application for a certificate of consent to self-insure against workers' compensation claims. The certificate shall be issued and be subject to the provisions of Section 3702."

I am aware of the provisions of Labor Code section 3700, which require every employer to be insured against liability for workers' compensation or to undertake self-insurance in accordance with the provisions of that code, and I will comply with such provisions before commencing the performance of the work of this contract.

Name of Contractor

By: _____
Signature

Print Name

Title

Date

(In accordance with Article 5 [commencing at Section 1860], Chapter 1, Part 7, Division 2 of the Labor Code, the above certificate must be signed and filed with the awarding body prior to performing any work under the Agreement.)

**CERTIFICATION OF PRIMARY PARTICIPANT
REGARDING DEBARMENT, SUSPENSION, AND OTHER
RESPONSIBILITY MATTERS**

The _____
Firm name/principal

certified to the best of its knowledge and belief, that it and its principals:

1. Are not presently debarred, suspended, proposed for debarment, declared ineligible, or voluntarily excluded from covered transactions by any federal department agency;
2. Have not within a three-year period preceding this proposal been convicted of a or had a civil judgment rendered against them for commission of fraud or a criminal offense in connection with obtaining, attempting to obtain, or performing a public (federal, state or local) transaction or contract under a public transaction; violation of federal or state antitrust or destruction of records, making false statements, or receiving stolen property;
3. Are not presently indicted for or otherwise criminally or civilly charged by a governmental entity (federal, state, or local), with commission of any of the offenses enumerated in paragraph (2) of this certification; and
4. Have not within a three-year period preceding this proposal had one or more public transactions (federal, state or local) terminated for cause of default.

If unable to certify to any of the statements in this certification, the participant shall attach an explanation to this certification.

THE PRIMARY PARTICIPANT _____
Firm name/principal

CERTIFIED OR AFFIRMS THE TRUTHFULNESS AND ACCURACY OF THE CONTENTS OF THE STATEMENTS SUBMITTED ON OR WITH THIS CERTIFICATION AND UNDERSTANDS THAT THE PROVISIONS OF 31 U.S.C. SECTION 3801 ET SEQ. ARE APPLICABLE THERETO.

Signature and Title of Authorized Official

CERTIFICATE OF RESTRICTIONS ON LOBBYING

I, _____, hereby certify on behalf (name of offeror) of _____ that:

(Firm Name)

1. No Federal appropriated funds have been paid, by or on behalf of the undersigned, to any person for influencing or attempting to influence an officer or employee of any agency, a Member of Congress, an officer or employee of Congress, or an employee of a Member of Congress in connection with the awarding of any Federal contract, the making of any Federal grant, the making of any Federal loan, the entering into of any cooperative agreement, and the extension, continuation, renewal, amendment, or modification of any Federal contract, grant, loan, or cooperative agreement.
2. If any funds, other than Federal appropriated funds, have been paid or will be paid to any person for influencing or attempting to influence an officer or employee of any agency, a Member of Congress, an officer or employee of Congress, or an employee of a Member of Congress in connection with this Federal contract, grant, loan, or cooperative agreement, the undersigned shall complete and submit the attached, Standard Form-LLL, "Disclosure of Lobbying Activities", in accordance with its instructions.
3. The undersigned shall require that the language of this certification be included in all subcontracts, and that all subcontracts shall certify and disclose accordingly.

This certification is a material representation of fact upon which reliance is placed when this transaction as made or entered into. Submission of this certification is a prerequisite for making or entering into this transaction imposed by section 1352, title 31, U.S. Code. Any person who fails to file the required certification shall be subject to civil penalty of not less than \$10,000 and not more than \$100,000 for each such failure.

Executed this _____ day of _____, 20____

By: _____
(Signature of authorized official)

(Title of authorized official)

AFTER AWARD

SAMPLE AGREEMENT AND REQUIRED DOCUMENTS ATTACHED HERETO

LEASE OF RELOCATABLE BUILDINGS
BID NO. 2026/27-1FA

SAMPLE

INDEPENDENT CONTRACTOR AGREEMENT

This AGREEMENT is hereby dated this XX day of Month, 20XX (the “Effective Date”) between the Irvine Unified School District (School Site), hereinafter referred to as “DISTRICT,” and Contractor’s Name, address, and phone number, hereinafter referred to as “CONTRACTOR.”

WHEREAS, DISTRICT is authorized by Section 53060 of the California Government Code to contract with and employ any persons for the furnishing of special Services and advice in financial, economic, accounting, engineering, legal or administrative matters, if such persons are specially trained and experienced and competent to perform the special Services required;

WHEREAS, DISTRICT is in need of such special services and advice; and

WHEREAS, CONTRACTOR is specially trained and experienced and competent to perform the special Services required by the DISTRICT, and such services are needed on a limited basis;

NOW, THEREFORE, the parties agree as follows:

1. Services to be provided by Contractor. Contractor shall provide XXXXXXXXXXXXXXXXXXXXX, hereinafter referred to as “Services”.
2. Term. Contractor shall commence providing Services under this Agreement on Month day, 20XX and will diligently perform as required and complete performance by Month day, 20XX.
3. Compensation. District agrees to pay the Contractor for Services satisfactorily rendered pursuant to this agreement a total fee not to exceed Amount In Words Dollars (\$XXXX.XX). DISTRICT shall pay Contractor within thirty (30) days of receipt of Contractor’s invoice detailing the services rendered.
4. Expenses. District shall not be liable to Contractor for any costs or expenses paid or incurred by CONTRACTOR in performing Services for District.
5. Independent Contractor. Contractor, in the performance of the Services pursuant to this Agreement, shall be and act as an independent contractor. Contractor understands and agrees that it and all of its employees shall not be considered officers, employees or agents of the District, and are not entitled to benefits of any kind or nature normally provided employees of the District and/or to which District’s employees are normally entitled, including, but not limited to, State Unemployment Compensation or Workers’ Compensation. Contractor assumes the full responsibility for the acts and/or omissions of its employees or agents as they relate to the Services to be provided under this Agreement. Contractor shall assume full responsibility for payment of all federal, state and local taxes or contributions, including unemployment insurance, social security and income taxes with respect to Contractor’s employees.

6. Materials. Contractor shall furnish, at its own expense, all labor, materials, equipment, supplies and other items necessary to complete the Services to be provided pursuant to this AGREEMENT. CONTRACTOR's Services will be performed in accordance with generally and currently accepted principles and practices of its profession.

7. Originality of Services/Intellectual Property. Contractor agrees that all ideas, technologies, formulae, procedures, processes and methods prepared for and submitted by Contractor to the District in connection with the Services set forth in this Agreement, shall be wholly original to Contractor and shall not be copied in whole or in part from any other source, except that submitted to Contractor by District as a basis for such Services. Contractor further agrees that all writings, materials, compositions, recordings, teleplays, and/or video productions prepared for, written for, or otherwise (hereinafter referred to as "Content") submitted by Contractor to the District and/or used in connection with the Services set forth in this Agreement, reflect the intellectual property of, and copyright interests held by District and shall not be copied or used in whole or in part by Contractor without District's express written permission. Contractor understands and agrees that all Content produced under this Agreement is the property of District and cannot be used without District's express written permission. Contractor acknowledges and agrees that District shall have all right, title and interest in said Content, including the right to secure and maintain the copyright, trademark and/or patent of said Content in the name of the District.

8. Termination. District may, at any time, with or without reason, terminate this Agreement and compensate Contractor only for Services satisfactorily rendered to the date of termination. Written notice by District shall be sufficient to stop further performance of Services by Contractor. Notice shall be deemed given when received by the Contractor or no later than three (3) days after the day of mailing, whichever is sooner.

District may terminate this Agreement upon giving of written notice of intention to terminate for cause. Cause shall include: (a) material violation of this Agreement by the Contractor; or (b) any act by Contractor exposing the District to liability to others for personal injury or property damage; or (c) Contractor is adjudged a bankrupt, Contractor makes a general assignment for the benefit of creditors or a receiver is appointed on account of Contractor's insolvency. Written notice by District shall contain the reasons for such intention to terminate and unless within ten (10) days after service of such notice the condition or violation shall cease, or satisfactory arrangements for the correction thereof be made, this Agreement shall upon the expiration of the ten (10) days cease and terminate. In the event of such termination, the District may secure the required Services from another contractor. If the cost to the District to secure the required Services from another contractor exceeds the cost of providing the Services pursuant to this Agreement, the excess cost shall be charged to and collected from the Contractor. The foregoing provisions are in addition to and not a limitation of any other rights or remedies available to District. Written notice by District shall be deemed given when received by the Contractor, or no later than three (3) days after the day of mailing, whichever is sooner.

9. Hold Harmless. Contractor agrees to and does hereby indemnify, hold harmless and defend the DISTRICT and its governing board, officers, employees and agents from every claim or demand made and every liability, loss, damage or expense, of any nature whatsoever, which may be incurred by reason of:

- (a) Liability for damages for: (1) death or bodily injury to person; (2) injury to, loss

or theft of property; or (3) any other loss, damage or expense arising out of (1) or (2) above, sustained by the Contractor or any person, firm or corporation employed by the CONTRACTOR, either directly or by independent contract, upon or in connection with the Services called for in this Agreement, however caused, except for liability for damages referred to above which result from the sole negligence or willful misconduct of the DISTRICT or its officers, employees or agents.

(b) Any injury to or death of any person(s), including the District’s officers, employees and agents, or damage to or loss of any property caused by any act, neglect, default, or omission of the Contractor, or any person, firm or corporation employed by the CONTRACTOR, either directly or by independent contract, arising out of, or in any way connected with, the Services covered by this Agreement, whether said injury or damage occurs either on or off District’s property, except for liability for damages which result from the sole negligence or willful misconduct of the District or its officers, employees or agents.

(c) Any liability for damages which may arise from the furnishing or use of any copyrighted or uncopyrighted matter or patented or unpatented invention under this AGREEMENT.

10. **Insurance.** Contractor shall insure Contractor’s activities in connection with the Services under this AGREEMENT and agrees to carry insurance to ensure Contractor’s ability to adhere to the indemnification requirements under this Agreement.

10.1 Contractor shall, at Contractor’s sole cost and expense, maintain in full force and effect the following insurance coverages from a California licensed insurer with an A, VIII, or better rating from A.M. Best or an approved self-insurance program, sufficient to cover any claims, damages, liabilities, costs and expenses (including attorney fees) arising out of or in connection with Contractor’s fulfillment of the obligations under this Agreement:

a. Comprehensive or Commercial General Liability Insurance, including bodily injury, property damage and contractual liability with minimum limits set by the District.

(1) General Aggregate	\$2,000,000
(2) Each Occurrence	\$1,000,000
(3) Products/Completed Operations	\$1,000,000
(4) Personal and Advertising Injury	\$1,000,000
(5) Damage to Rented Premises	\$50,000
(6) Medical Expense (any one person)	\$5,000

b. Sexual Abuse and Molestation liability coverage with minimum limits of \$1,000,000 per occurrence and \$2,000,000 aggregate, unless waived/reduced by the District.

c. Umbrella (excess) liability insurance coverage with a minimum limit of \$3,000,000, unless waived/reduced by the District. The policy shall follow

form to the general liability policy and shall not contain an exclusion for sexual molestation and abuse coverage.

d. Business Automobile Liability Insurance for owned, scheduled, non-owned, or hired automobiles with a combined single limit not less than \$1,000,000 per occurrence. (Required only if the Contractor drives on behalf of the District in the course of performing Services.)

e. Professional Liability Insurance with a limit of \$1,000,000 per occurrence, unless waived/reduced by the District.

f. Workers' Compensation and Employers Liability Insurance in a form and amount covering Contractor's full liability under the California Workers' Compensation Insurance and Safety Act and in accordance with applicable state and federal laws. The policy shall be endorsed with the insurer's waiver of rights of subrogation against the District.

It should be expressly understood, however, that the coverage and limits referred to under (a), (b), (c), (d) and (e) above shall not in any way limit the liability of the Contractor.

10.2 No later than ten (10) days from execution of this Agreement by the District and Contractor, and prior to commencing the Services under this Agreement, Contractor shall provide District with certificates of insurance evidencing all coverages and endorsements required hereunder.

Contractor shall provide prior written notice to the District thirty (30) days in advance of any non-renewal, cancellation, or modification of the required insurance. The certificates of insurance providing the coverages referred to in clauses (a) and (b) above shall name District, its Governing Board, officers, and employees, as additional insureds with appropriate endorsements. In addition, the certificates of insurance shall include a provision stating "Such insurance as is afforded by this policy shall be primary, and any insurance carried by District shall be excess and noncontributory." Failure to maintain the above mentioned insurance coverages shall be cause for termination of this Agreement.

11. Assignment. The obligations of the Contractor pursuant to this Agreement shall not be assigned by the Contractor.

1. 12. Compliance With Applicable Laws The Services completed herein must meet the approval of the District and shall be subject to the District's general right of inspection to secure the satisfactory completion thereof. Contractor agrees to comply with all federal, state and local laws, rules, regulations and ordinances that are now or may in the future become applicable to Contractor, Contractor's business, the Services, equipment and personnel engaged in Services covered by this Agreement or accruing out of the performance of such Services.

12.1 Fingerprinting. Education Code section 45125.1 requires that employees of a contractor under contract with a school district shall ensure that such employees who check, unless the District determines that the Contractor interact with students outside of

the immediate supervision and control of the student’s parent or guardian or a school district employee must be fingerprinted by the California Department of Justice for a criminal records summary. If a criminal records summary is required, the Contractor expressly agrees that Contractor and all of Contractor’s current and subsequent employees will submit or have submitted fingerprints in a manner required by the California Department of Justice, as set forth in Education Code section 45125.1. Contractor and/or Contractor’s current and subsequent employees shall not come in contact with students until the California Department of Justice has ascertained that the Contractor and/or Contractor’s employees have not been convicted of a violent felony as defined in Penal Code section 667.5(c) or a serious felony as defined in Penal Code section 1192.7(c). Contractor shall certify in writing Contractor’s compliance with Education Code section 45125.1 to the Governing Board of the District. Contractor’s certification shall be signed by Contractor under penalty of perjury under the laws of the State of California, and submitted to the District representative executing this Agreement. Contractor shall fulfill these requirements at its own expense. The District may require the Contractor and its current and subsequent employees to submit to additional criminal records checks at the District’s sole and absolute discretion.

The Services and scope of work defined in this Agreement

will (*Contractor **must complete Exhibit A** prior to rendering Services.*)

will not (*Exhibit A is not applicable.*)

require the Contractor to submit to fingerprinting.

Contractor’s Signature: _____

District Administrator’s Signature: _____

13. Permits/Licenses. Contractor and all Contractor’s employees or agents shall secure and maintain in force such permits and licenses as are required by law in connection with the furnishing of Services pursuant to this Agreement.

14. Employment With Public Agency. Contractor, if an employee of another public agency, agrees that Contractor will not receive salary or remuneration, other than vacation pay, as an employee of another public agency for the actual time in which Services are actually being performed pursuant to this Agreement.

15. Force Majeure. Neither party shall be deemed to be in violation of this Agreement if either is prevented from performing any of its obligations hereunder for any reason beyond its reasonable control, including but not limited to acts of God, natural disasters, earthquake, fire, flood, strikes, civil commotion, labor disputes, war, terrorism, infectious disease, and pandemics. If such an event continues for sixty (60) or more days, either party may terminate this Agreement by providing a written notification and shall not be liable to the other for failure to perform its obligation and any deposits or any pre-paid fees shall be refunded on a pro-rated basis.

16. Entire Agreement/Amendment. This Agreement and any exhibits attached hereto constitute the entire Agreement between the parties and supersedes any prior or contemporaneous understanding or agreement with respect to the Services contemplated, and may be amended only

by a written amendment executed by both parties to the Agreement. This Agreement incorporates by this reference, any exhibits, which are attached hereto and incorporated herein.

17. Nondiscrimination. Contractor agrees that Contractor will not engage in unlawful discrimination in employment of persons because of race, ethnicity, religion, nationality, disability, gender, sex, marital status, age, or other characteristics protected by federal or state laws.

18. Non Waiver. The failure of District or Contractor to seek redress for violation of, or to insist upon, the strict performance of any term or condition of this Agreement, shall not be deemed a waiver by that party of such term or condition, or prevent a subsequent similar act from again constituting a violation of such term or condition.

19. Notice. All notices or demands to be given under this Agreement by either party to the other shall be in writing and given either by: (a) personal service or (b) by U.S. Mail, mailed either by registered or certified mail, return receipt requested, with postage prepaid. Service shall be considered given when received if personally served or if mailed on the third day after deposit in any U.S. Post Office. The address to which notices or demands may be given by either party may be changed by written notice given in accordance with the notice provisions of this section. At the date of this Agreement, the addresses of the parties are as follows:

District:	Contractor:
Irvine Unified School District	Company Name
5050 Barranca Parkway	Address
Irvine, CA 92604	City, State, Zip
Attn: Asst. Superintendent, Business Services	Attn:

20. Severability. If any term, condition or provision of this Agreement is held by a court of competent jurisdiction to be invalid, void, or unenforceable, the remaining provisions will nevertheless continue in full force and effect, and shall not be affected, impaired or invalidated in any way.

21. Attorney Fees/Costs. Should litigation be necessary to enforce any terms or provisions of this Agreement, then each party shall bear its own litigation and collection expenses, witness fees, court costs, and attorneys' fees.

22. Headings. The headings contained in this Agreement are provided exclusively for reference and the convenience of the parties. No legal significance of any type shall be attached to the headings.

23. Counterparts. This Agreement may be signed and delivered in two (2) counterparts, each of which, when so signed and delivered, shall be an original, but such counterparts together shall constitute the one (1) instrument that is the Agreement, and the Agreement shall not be binding on any party until all Parties have signed it.

24. Authorized Signatures. The individual signing this Agreement warrants that he/she is authorized to do so. The parties understand and agree that a breach of this warranty shall constitute a breach of the Agreement and shall entitle the non-breaching party to all appropriate legal and equitable remedies against the breaching party.

25. Governing Law. The terms and conditions of this Agreement shall be governed by the

laws of the State of California with venue in Orange County, California. This Agreement is made in and shall be performed in Orange County, California.

This Agreement is hereby dated as of the Effective Date.

IRVINE UNIFIED SCHOOL DISTRICT

CONTRACTOR

By: _____

Name: John Fogarty

Title: Asst. Superintendent, Business Services
(a Board Authorized IUSD rep. will sign for IUSD)

District Board Approved:

By: _____

Name:

Title:

Taxpayer Identification No.:

EXHIBIT A

If required, Services shall not begin until Individual / Contractor returns this Certification.

NOTICE TO INDIVIDUALS / CONTRACTORS
REGARDING VALID CRIMINAL RECORDS SUMMARY
(EDUCATION CODE SECTION 45125.1)

Education Code Section 45125.1 provides that anyone who has a contract with a local education agency (school district) shall ensure that any individual / employee who interacts with students outside of the immediate supervision and control of the student’s parent or guardian or a District/school employee has a valid criminal records summary resulting from submission of the individual’s / employee’s fingerprints in a manner authorized by the Department of Justice (DOJ).

The DOJ shall ascertain whether the individual / employee whose fingerprints were submitted to it has been arrested or convicted of any crime insofar as that fact can be ascertained from information available to the DOJ.

The local education agency shall not permit an individual nor shall the contractor permit its employees to come in contact with any student until the DOJ has ascertained that the individual / employee has not been convicted of a violent felony as defined in Penal Code section 667.5(c) or serious felony as defined in Penal Code section 1192.7(c). The individual / contractor shall certify in writing to the governing board of the school district that he/she or its employees who may come in contact with any student has not been convicted of a violent or serious felony.



CERTIFICATION BY INDIVIDUAL / CONTRACTOR

Check one: Individual Contractor

To the Governing Board of Irvine Unified School District:

I, _____, am the _____, of _____
Name of Individual Title Name of Contractor, if applicable

and I am authorized to execute this Certification on behalf of myself or the Contractor.

1. I have carefully read and understand the Notice to Individuals / Contractors Regarding a Valid Criminal Records Summary required under Education Code Section 45125.1.
2. Due to the nature of the services that will be provided to the District, I / Contractor’s employees will or may have contact with students of the District outside of the immediate supervision and control of the student’s parent or guardian or District employee.

3. I have obtained and reviewed the valid Criminal Records Summary of myself / my employees who will be performing services for the District. If any subsequent/future employees will be performing services for the District, I will obtain and review the Valid Criminal Records Summary of these employees and submit an updated Certification to the District.

4. I, nor any of the employees who will be providing services to the District have been convicted of a violent felony as defined in Penal Code section 667.5(c) or serious felony as defined in Penal Code Section 1192.7(c), and this determination was made by a fingerprint check through the Department of Justice.

I declare under penalty of perjury, under the laws of the State of California, that the foregoing is true and correct.

Executed at _____, California on _____
Date

Signature

Typed or Printed Name

Title

Name of Contractor, if applicable

Address

Telephone Number

DISTRICT INSURANCE REQUIREMENT SAMPLES

Irvine Unified School District Insurance Requirements

All insurers must be duly licensed and admitted by the State of California.

Mandatory Requirements (unless District reduces or excludes coverage requirements)

1. Commercial General Liability insurance for bodily injury and property damage, including accidental death, in the combined single limit of not less than \$1,000,000 per occurrence (\$2,000,000 aggregate) and \$3,000,000 Excess/Umbrella liability.
 - e. Sexual Abuse/Molestation coverage must be included under General Liability or obtained in separate policies in an amount of not less than \$1,000,000 per occurrence (\$2,000,000 aggregate) and \$3,000,000 Excess/Umbrella liability.

Minimum Limits (if required by District)

1. Automobile Liability insurance for bodily injury and property damage in an amount of not less than \$1,000,000 per occurrence with no annual aggregate limit.
2. Workers' Compensation and Employer's Liability insurance in the amount of not less than \$1,000,000 per occurrence.
3. Professional Liability insurance in an amount of not less than \$1,000,000 per occurrence (\$2,000,000 aggregate). If Professional Liability policy is made on a claims-made basis, the vendor/consultant must purchase and maintain an extending reporting period (tail coverage) for one year, unless otherwise specified.

Additional Insured Endorsement Language

"Irvine Unified School District, its Board of Trustees, officers, agents, employees, and volunteers are named as additionally insured on this policy pursuant to written contract, agreement, or memorandum of understanding. Such insurance as is afforded by this policy shall be primary, and any insurance carried by District shall be excess and noncontributory."

Additional Insured Endorsements are required to accompany Certificates of Insurance. Certificate of Insurance shall provide thirty (30) day prior written notice of cancellation.

See sample certificate on the Irvine Unified School District website <http://www.iusd.org>.

Additional Required Documents

Certificates of Insurance must be accompanied by a list of all excluded coverages under the general liability and excess/umbrella liability policies. The exclusion policy document section may be emailed or faxed to Risk Management & Insurance. The general liability and excess/umbrella liability documents must list the corresponding policy numbers referenced on the Certificate of Insurance.

Questions may be directed to Risk Management & Insurance at:

Email: Insurance@iusd.org

Fax: (949) 936-5019

Revised: September 2018

SAMPLE

ACORD™ CERTIFICATE OF LIABILITY INSURANCE		DATE (MMDDYYYY) INSERT DATE
PRODUCER NAME & ADDRESS OF INSURANCE COMPANY	THIS CERTIFICATE IS ISSUED AS A MATTER OF INFORMATION ONLY AND CONFERS NO RIGHTS UPON THE CERTIFICATE HOLDER. THIS CERTIFICATE DOES NOT AMEND, EXTEND OR ALTER THE COVERAGE AFFORDED BY THE POLICIES BELOW.	
INSURED NAME & ADDRESS OF COMPANY/ORGANIZATION	INSURERS AFFORDING COVERAGE INSURER A: Name of Insurance Company INSURER B: Name of Insurance Company INSURER C: Name of Insurance Company INSURER D: Name of Insurance Company INSURER E: Name of Insurance Company	NAIC #

COVERAGES
 THE POLICIES OF INSURANCE LISTED BELOW HAVE BEEN ISSUED TO THE INSURED NAMED ABOVE FOR THE POLICY PERIOD INDICATED. NOTWITHSTANDING ANY REQUIREMENT, TERM OR CONDITION OF ANY CONTRACT OR OTHER DOCUMENT WITH RESPECT TO WHICH THIS CERTIFICATE MAY BE ISSUED OR MAY PERTAIN, THE INSURANCE AFFORDED BY THE POLICIES DESCRIBED HEREIN IS SUBJECT TO ALL THE TERMS, EXCLUSIONS AND CONDITIONS OF SUCH POLICIES. AGGREGATE LIMITS SHOWN MAY HAVE BEEN REDUCED BY PAID CLAIMS.

INSR	ADD'L	TYPE OF INSURANCE	POLICY NUMBER	POLICY EFFECTIVE DATE (MMDDYY)	POLICY EXPIRATION DATE (MMDDYY)	LIMITS
		<input checked="" type="checkbox"/> GENERAL LIABILITY <input checked="" type="checkbox"/> COMMERCIAL GENERAL LIABILITY <input type="checkbox"/> CLAIMS MADE <input checked="" type="checkbox"/> OCCUR GEN'L AGGREGATE LIMIT APPLIES PER: <input type="checkbox"/> POLICY <input type="checkbox"/> PROJ-JECT <input type="checkbox"/> LOC	MANDATORY REQUIREMENTS	Insert Date	Insert Date	EACH OCCURRENCE \$ 1,000,000 DAMAGE TO RENTED PREMISES (Ea occurr/ptoc) \$ 50,000 MED EXP (Any one person) \$ 5,000 PERSONAL & ADV INJURY \$ 1,000,000 GENERAL AGGREGATE \$ 2,000,000 PRODUCTS - COMP/OP AGG \$ 1,000,000
		<input checked="" type="checkbox"/> AUTOMOBILE LIABILITY <input checked="" type="checkbox"/> ANY AUTO <input type="checkbox"/> ALL OWNED AUTOS <input type="checkbox"/> SCHEDULED AUTOS <input type="checkbox"/> HIRED AUTOS <input type="checkbox"/> NON-OWNED AUTOS	REQUIRED IF APPLICABLE TO SERVICE	Insert Date	Insert Date	COMBINED SINGLE LIMIT (Ea accident) \$ 1,000,000 BODILY INJURY (Per person) \$ BODILY INJURY (Per accident) \$ PROPERTY DAMAGE (Per accident) \$
		<input type="checkbox"/> GARAGE LIABILITY <input type="checkbox"/> ANY AUTO				AUTO ONLY - EA ACCIDENT \$ OTHER THAN EA ACC \$ AUTO ONLY: AGG \$
		<input checked="" type="checkbox"/> EXCESS/UMBRELLA LIABILITY <input checked="" type="checkbox"/> OCCUR <input type="checkbox"/> CLAIMS MADE <input type="checkbox"/> DEDUCTIBLE <input type="checkbox"/> RETENTION \$	REQUIRED UNLESS REDUCED/WAIVED	Insert Date	Insert Date	EACH OCCURRENCE \$ 3,000,000 AGGREGATE \$ \$ \$
		WORKERS COMPENSATION AND EMPLOYERS' LIABILITY ANY PROPRIETOR/PARTNER/EXECUTIVE OFFICER/MEMBER EXCLUDED? If yes, describe under SPECIAL PROVISIONS below	REQUIRED UNLESS REDUCED/WAIVED	Insert Date	Insert Date	<input checked="" type="checkbox"/> WC/STAT/TPD/INTS <input type="checkbox"/> OTH-ER E.L. EACH ACCIDENT \$ 1,000,000 E.L. DISEASE - EA EMPLOYEE \$ 1,000,000 E.L. DISEASE - POLICY LIMIT \$ 1,000,000
		OTHER Professional Liability and/or Sexual Abuse/Molestation	MAY BE REQUIRED	Insert Date	Insert Date	\$ 1,000,000 per occurrence \$ 2,000,000 aggregate

DESCRIPTION OF OPERATIONS/LOCATIONS/VEHICLES/EXCLUSIONS ADDED BY ENDORSEMENT/SPECIAL PROVISIONS
 Irvine Unified School District, its Board of Trustees, officers, agents, employees, and volunteers are named as additionally insured on this policy pursuant to written contract, agreement, or memorandum of understanding. Such insurance as is afforded by this policy shall be primary, and any insurance carried by District shall be excess and noncontributory. Sexual Abuse/Molestation is not excluded from coverage under the general liability and excess/umbrella liability policies. (Provide brief description of services/dates).

CERTIFICATE HOLDER Irvine Unified School District 5050 Barranca Parkway Irvine, California 92604 Attention: Risk Management	CANCELLATION SHOULD ANY OF THE ABOVE DESCRIBED POLICIES BE CANCELLED BEFORE THE EXPIRATION DATE THEREOF, THE ISSUING INSURER WILL ENDEAVOR TO MAIL <u>30</u> DAYS WRITTEN NOTICE TO THE CERTIFICATE HOLDER NAMED TO THE LEFT, BUT FAILURE TO DO SO SHALL IMPOSE NO OBLIGATION OR LIABILITY OF ANY KIND UPON THE INSURER, ITS AGENTS OR REPRESENTATIVES. AUTHORIZED REPRESENTATIVE _____ <div style="text-align: right;">SIGNATURE REQUIRED</div>
--	--

ACORD 25 (2001/08)
 INS025 (01/08) 08a

© ACORD CORPORATION 1988
 Page 1 of 1

ENDORSEMENT

ADDITIONAL COVERED PARTY

COVERED PARTY
(INSERT INSURED NAME)

COVERAGE DOCUMENT
(INSERT POLICY NUMBER)

ADMINISTRATOR
(INSERT NAME OF ADMINISTRATOR)

Subject to all terms, conditions, exclusions, and endorsements, such additional covered party as is afforded by the coverage document shall also apply to the following entity but only as respects to liability arising from the actions and activities of the covered party described below.

Additional Covered Party:

Irvine Unified School District
5050 Barranca Parkway
Irvine, California 92604

Description of Activities:

Irvine Unified School District, its Board of Trustees, officers, agents, employees, and volunteers are named as additionally insured on this policy pursuant to written contract, agreement, or memorandum of understanding. Such insurance as is afforded by this policy shall be primary, and any insurance carried by District shall be excess and noncontributory.

Authorized Representative Signature
MUST APPEAR ON THE ENDORSEMENT PAGE

SAMPLE

FAITHFUL PERFORMANCE BOND

KNOW ALL MEN BY THESE PRESENTS:

THAT WHEREAS, the **IRVINE UNIFIED SCHOOL DISTRICT** (sometimes referred to hereinafter as “Obligee”) has awarded to _____ (hereinafter designated as the “Principal” or “Contractor”), an agreement for the work described as follows: **Lease of Relocatable Buildings, Bid No. 2026/27-1FA** (hereinafter referred to as the “Public Work”); and

WHEREAS, the work to be performed by the Contractor is more particularly set forth in that certain contract for said Public Work dated _____, (hereinafter referred to as the “Contract”), which Contract is incorporated herein by this reference; and

WHEREAS, the Contractor is required by said Contract to perform the terms thereof and to provide a bond both for the performance and guaranty thereof.

NOW, THEREFORE, we, _____, the undersigned Contractor, as Principal, and _____, a corporation organized and existing under the laws of the State of _____, and duly authorized to transact business under the laws of the State of California, as Surety, are held and firmly bound unto the IRVINE UNIFIED SCHOOL DISTRICT in the sum of _____ Dollars (\$ _____), said sum being not less than one hundred percent (100%) of the total amount payable by said Obligee under the terms of said Contract, for which amount well and truly to be made, we bind ourselves, our heirs, executors, administrators, successors, and assigns, jointly and severally, firmly by these presents.

THE CONDITION OF THIS OBLIGATION IS SUCH THAT, if the bounded Contractor, his or her heirs, executors, administrators, successors or assigns, shall in all things stand to and abide by, and well and truly keep and perform the covenants, conditions, and agreements in said Contract and any alteration thereof made as therein provided, on his or her part, to be kept and performed at the time and in the manner therein specified, and in all respects according to their intent and meaning; and shall faithfully fulfill guarantees of all materials and workmanship; and indemnify, defend and save harmless the Obligee, its officers and agents, as stipulated in said Contract, then this obligation shall become null and void; otherwise it shall be and remain in full force and effect.

The Surety, for value received, hereby stipulates and agrees that it shall not be exonerated or released from the obligation of this bond (either by total exoneration or pro tanto) by any change, extension of time, alteration in or addition to the terms of the contract or to the work to be performed there under or the specifications accompanying the same, nor by any change or modification to any terms of payment or extension of time for any payment pertaining or relating to any scheme of work of improvement under the contract. Surety also stipulates and agrees that it shall not be exonerated or released from the obligation of this bond (either by total exoneration or pro tanto) by any overpayment or underpayment by the Obligee that is based upon estimates approved by the Architect. The Surety stipulates and agrees that none of the aforementioned changes, modifications, alterations, additions, extension of time or actions shall in any way affect its obligation on this bond, and it does hereby waive notice of any such changes, modifications, alterations, additions or extension of time to the terms of the contract, or to the work, or the specifications as well notice of any other actions that result in the foregoing.

Whenever Principal shall be, and is declared by the Obligees to be, in default under the Contract, the Surety shall promptly either remedy the default, or shall promptly take over and complete the Contract through its agents or independent contractors, subject to acceptance and approval of such agents or independent contractors by Obligees as hereinafter set forth, in accordance with its terms and conditions and to pay and perform all obligations of Principal under the Contract, including, without limitation, all obligations with respect to warranties, guarantees and the payment of Liquidated Damages; or, at Obligees' sole discretion and election, Surety shall obtain a bid or bids for completing the Contract in accordance with its terms and conditions, and upon determination by Obligees of the lowest responsible bidder, arrange for a contract between such bidder and the Obligees and make available as Work progresses (even though there should be a default or succession of defaults under the contract or contracts of completion arranged under this paragraph) sufficient funds to pay the cost of completion less the "balance of the Contract Price" (as hereinafter defined), and to pay and perform all obligations of Principal under the Contract, including, without limitation, all obligations with respect to warranties, guarantees and the payment of Liquidated Damages. The term "balance of the Contract Price," as used in this paragraph, shall mean the total amount payable to Principal by the Obligees under the Contract and any modifications thereto, less the amount previously paid by the Obligees to the Principal, less any withholdings by the Obligees allowed under the Contract. Obligees shall not be required or obligated to accept a tender of a completion contractor from the Surety.

Surety expressly agrees that the Obligees may reject any agent or contractor, which may be proposed by Surety in fulfillment of its obligations in the event of default by the Principal. Unless otherwise agreed by Obligees, in its sole discretion, Surety shall not utilize Principal in completing the Contract nor shall Surety accept a bid from Principal for completion of the work in the event of default by the Principal.

No final settlement between the Obligees and the Contractor shall abridge the right of any beneficiary hereunder, whose claim may be unsatisfied.

The Surety shall remain responsible and liable for all patent and latent defects that arise out of or relate to the Contractor's failure and/or inability to properly complete the Public Work as required by the Contract and the Contract Documents. The obligation of the Surety hereunder shall continue so long as any obligation of the Contractor remains.

Contractor and Surety agree that if the Obligees is required to engage the services of an attorney in connection with enforcement of the bond, Contractor and Surety shall pay Obligees' reasonable attorneys' fees incurred, with or without suit, in addition to the above sum.

In the event suit is brought upon this bond by the Obligees and judgment is recovered, the Surety shall pay all costs incurred by the Obligees in such suit, including reasonable attorneys' fees to be fixed by the Court.

IN WITNESS WHEREOF, we have hereunto set our hands and seals this _____ day of _____, 20__.

PRINCIPAL/CONTRACTOR:

By: _____

SURETY:

By: _____

Attorney-in-Fact

The rate of premium on this bond is _____ per thousand.

The total amount of premium charged: \$_____ (This must be filled in by a corporate surety).

PAYMENT BOND

KNOW ALL MEN BY THESE PRESENTS:

THAT WHEREAS, the **IRVINE UNIFIED SCHOOL DISTRICT** (sometimes referred to hereinafter as “Obligee”) has awarded to _____ (hereinafter designated as the “Principal” or “Contractor”), an agreement for the work described as follows: **Lease of Relocatable Buildings, Bid No. 2026/27-1FA** (hereinafter referred to as the “Public Work”); and

WHEREAS, said Contractor is required to furnish a bond in connection with said Contract, and pursuant to California Civil Code section 9550;

NOW, THEREFORE, We, _____, the undersigned Contractor, as Principal; and _____, a corporation organized and existing under the laws of the State of _____, and duly authorized to transact business under the laws of the State of California, as Surety, are held and firmly bound unto the IRVINE UNIFIED SCHOOL DISTRICT and to any and all persons, companies, or corporations entitled by law to file stop notices under California Civil Code section 9100, or any person, company, or corporation entitled to make a claim on this bond, in the sum of _____ Dollars (\$ _____), such sum being not less than one hundred percent (100%) of the total amount payable by said Obligee under the terms of said Contract, for which payment will and truly to be made, we bind ourselves, our heirs, executors and administrators, successors and assigns, jointly and severally, firmly by these presents.

THE CONDITION OF THIS OBLIGATION IS SUCH that if said Principal, its heirs, executors, administrators, successors, or assigns, or subcontractor, shall fail to pay any person or persons named in Civil Code section 9100; or fail to pay for any materials, provisions, or other supplies, used in, upon, for, or about the performance of the work contracted to be done, or for any work or labor thereon of any kind, or for amounts due under the Unemployment Insurance Code, with respect to work or labor thereon of any kind; or shall fail to deduct, withhold, and pay over to the Employment Development Department, any amounts required to be deducted, withheld, and paid over by Unemployment Insurance Code section 13020 with respect to work and labor thereon of any kind, then said Surety will pay for the same, in an amount not exceeding the amount herein above set forth, and in the event suit is brought upon this bond, also will pay such reasonable attorneys’ fees as shall be fixed by the court, awarded and taxed as provided in California Civil Code section 9550 et seq.

This bond shall inure to the benefit of any person named in Civil Code section 9100 giving such person or his/her assigns a right of action in any suit brought upon this bond.

It is further stipulated and agreed that the Surety of this bond shall not be exonerated or released from the obligation of the bond by any change, extension of time for performance, addition, alteration or modification in, to, or of any contract, Plans, or specifications, or agreement pertaining or relating to any scheme or work of improvement herein above described; or pertaining or relating to the furnishing of labor, materials, or equipment therefor; nor by any change or modification of any terms of payment or extension of time for payment pertaining or relating to any scheme or work of improvement herein above described; nor by any rescission or attempted rescission of the contract, agreement or bond; nor by any conditions precedent or subsequent in the bond attempting to limit the right of recovery of claimants otherwise entitled to recover under any such contract or agreement or under the bond; nor by any fraud practiced by any person other than the claimant

seeking to recover on the bond; and that this bond be construed most strongly against the Surety and in favor of all persons for whose benefit such bond is given; and under no circumstances shall the Surety be released from liability to those for whose benefit such bond has been given, by reason of any breach of contract between the Obligee and the Contractor or on the part of any obligee named in such bond; that the sole condition of recovery shall be that the claimant is a person described in California Civil Code section 9100, and who has not been paid the full amount of his or her claim; and that the Surety does hereby waive notice of any such change, extension of time, addition, alteration or modification herein mentioned.

IN WITNESS WHEREOF this instrument has been duly executed by the Principal and Surety above named, on the _____ day of _____, 20____.

PRINCIPAL/CONTRACTOR:

By: _____

SURETY:

By: _____

Attorney-in-Fact

**CONTRACTOR'S CERTIFICATE REGARDING
NON-ASBESTOS CONTAINING MATERIALS**

Per Article 69 of the General Conditions.

Certification for _____. We hereby certify that no Asbestos, or Asbestos Containing Materials shall be used in this Project or in any tools, devices, clothing, or equipment used to affect the _____ which we have installed in the **Irvine Unified School District** under the **Purchase of Relocatable & Modular Buildings, Bid No. 2026/27-2FA**.

- (a) The Contractor further certifies that he/she has instructed his/her employees with respect to the above mentioned standards, hazards, risks and liabilities.
- (b) Asbestos and/or asbestos containing material shall be defined as all items containing but not limited to chrysotile, corcidolite, amosite, anthophyllite, tremolite and actinolite.
- (c) Any or all material containing greater than one-tenth of one percent (.1%) asbestos shall be defined as asbestos containing material.
- (d) Any disputes involving the question of whether or not material contains asbestos shall be settled by electron microscopy. The costs of any such tests shall be paid by the Contractor if the material is found to contain asbestos.
- (e) All work or materials found to contain asbestos or work or material installed with asbestos containing equipment will be immediately rejected and this work will be removed at no additional cost to the District.

Date

Name of Contractor

By: _____
Signature

Print Name

Title

**CERTIFICATION – PARTICIPATION OF
DISABLED VETERAN BUSINESS ENTERPRISES
IN ACCORDANCE WITH EDUCATION CODE 17076.11**

In accordance with Education Code Section 17076.11, the **Irvine Unified School District** has a participation goal for Disabled Veteran Business Enterprises of at least three percent (3%) per year of the overall dollar amount of funds allocated by the District by the State Allocation Board pursuant to the Leroy F. Greene School Facilities Act of 1998 for construction or modernization of school buildings and expended each year by the District. At the time of execution of the contract, the Contractor will provide a statement to the District of anticipated participation of Disabled Veteran Business Enterprises in the contract. Prior to, and as a condition precedent for final payment under the contract, the Contractor will provide appropriate documentation to the District identifying the amount paid to Disabled Veteran Business Enterprises pursuant to the contract, so that the District can assess its success at meeting this goal.

The Contractor may provide the anticipated participation of Disabled Veteran Business Enterprises in terms of percentage of its total contract or the dollar amount anticipated to be paid to Disabled Veteran Business Enterprises or by providing the names of the Disabled Veteran Business Enterprises that will participate in the contract. If there is a discrepancy between the anticipated goals and the actual goals at completion of the contract or a failure to meet the anticipated goal or dollar amounts, the District will require the Contractor to provide, at the completion of the contract, a detailed statement of the reason(s) for the discrepancy or failure to meet the anticipated goals or dollar amounts.

I certify that I have read the above and will comply with the anticipated participation of Disabled Veteran Business Enterprises in this contract.

Signature

Typed or Printed Name

Title

Company

Address

City, State, Zip

Telephone

Fax

E-mail

GUARANTEE

Guarantee for _____. We hereby guarantee that the _____,
which we have installed in _____

_____, has been done in accordance with the Project Documents and that the work as installed will fulfill the requirements included in the Project Documents. The undersigned agrees to repair or replace any or all of such work, together with any other adjacent work which may be displaced in connection with such repair or replacement, that may prove to be defective in workmanship or material within a period of one (1) year from the date of completion of the Project, ordinary wear and tear and unusual abuse or neglect excepted.

In the event of the undersigned's or undersigned surety's failure to commence and pursue with diligence said repairs or replacements within ten (10) calendar days after being notified in writing by the DISTRICT, the undersigned authorizes the DISTRICT to proceed to have said defects repaired or replaced and made good at the expense of the undersigned and surety who hereby agree to pay the costs and charges therefore immediately upon demand. (General Conditions Article 46(d))

Name of Contractor

Name of Subcontractor
(if work performed by a subcontractor)

By: _____
Signature of Contractor

By: _____
Signature of Subcontractor

Print Name

Print Name

Title

Title

Representatives to be contacted for service:

Name: _____

Address: _____

Telephone Number: _____

Contractor shall provide copy of this Guarantee to Contractor's surety.

DRUG-FREE WORKPLACE CERTIFICATION

This Drug-Free Workplace Certification is required pursuant to Government Code Sections 8350, et seq., the Drug-Free Workplace Act of 1990. The Drug-Free Workplace Act of 1990 requires that every person or organization awarded a contract for the procurement of any property or services from any State agency must certify that it will provide a drug-free workplace by doing certain specified acts. In addition, the Act provides that each contract awarded by a State agency may be subject to suspension of payments or termination of the contract and the contractor may be subject to debarment from future contracting, if the state agency determines that specified acts have occurred.

Pursuant to Government Code Section 8355, every person or organization awarded a contract from a State agency shall certify that it will provide a drug-free workplace by doing all of the following:

- a) Publishing a statement notifying employees that the unlawful manufacture, distribution, dispensation, possession or use of a controlled substance is prohibited in the person's or organization's workplace and specifying actions which will be taken against employees for violations of the prohibition
- b) Establishing a drug-free awareness program to inform employees about all of the following:
 - 1) The dangers of drug abuse in the workplace;
 - 2) The person's or organization's policy of maintain a drug-free workplace;
 - 3) The availability of drug counseling, rehabilitation and employee-assistance programs;
 - 4) The penalties that may be imposed upon employees for drug abuse violations;
- c) Requiring that each employee engaged in the performance of the contract be given a copy of the statement required by subdivision (a) and that, as a condition of employment on the contract, the employee agrees to abide by the terms of the statement.

I, the undersigned, agree to fulfill the terms and requirements of Government Code Section 8355 listed above and will publish a statement notifying employees concerning (a) the prohibition of controlled substance at the workplace, (b) establishing a drug-free awareness program, and (c) requiring that each employee engaged in the performance of the contract be given a copy of the statement required by Section 8355(a) and requiring that the employee agree to abide by the terms of that statement.

I also understand that if the DISTRICT determines that I have either (a) made a false certification herein, or (b) violated this certification by failing to carry out the requirements of Section 8355, that the contract awarded herein is subject to suspension of payments, termination, or both. I further understand that, should I violate the terms of the Drug-Free Workplace Act of 1990, I may be subject to debarment in accordance with the requirements of Section 8350, et seq.

I acknowledge that I am aware of the provisions of Government Code Section 8350, et seq. and hereby certify that I will adhere to the requirements of the Drug-Free Workplace Act of 1990.

Name of Contractor/Print

Signature

Title

Date

TOBACCO USE POLICY
IRVINE UNIFIED SCHOOL DISTRICT
Irvine, California

In the interest of public health, the Irvine Unified School District provides a tobacco-free environment. Smoking, or the use of any tobacco products are prohibited in the buildings, vehicles, and on any property owned, leased or contracted for, by the District. Failure to abide with this requirement could result in the termination of this contract.

I acknowledge that I am aware of the Tobacco Use Policy and hereby certify that I and my employees will adhere to the requirements of the policy.

Name of Bidder

Signature

Date

NOTICE REGARDING CRIMINAL RECORDS CHECK
EDUCATION CODE SECTION 45125.1

Education Code Section 45125.1 provides that if the employees of any entity that has a contract with a school district may have any contact with pupils, those employees shall submit or have submitted their fingerprints in a manner authorized by the Department of Justice together with a fee determined by the Department of Justice to be sufficient to reimburse the Department for its costs incurred in processing the application

The Department of Justice shall ascertain whether the individual whose fingerprints were submitted to it has been arrested or convicted of any crime insofar as that fact can be ascertained from information available to the Department. When the Department of Justice ascertains that an individual whose fingerprints were submitted to it has a pending criminal proceeding for a violent felony listed in Penal Code Section 1192.7(c), or has been convicted of such a felony, the Department shall notify the employer designated by the individual of the criminal information pertaining to the individual. The notification shall be delivered by telephone and shall be confirmed in writing and delivered to the employer by first-class mail.

The contractor shall not permit an employee to come in contact with pupils until the Department of Justice has ascertained that the employee has not been convicted of a violent or serious felony. The contractor shall certify in writing to the governing board of the school district that none of its employees who may come in contact with pupils have been convicted of a violent or serious felony.

Penal Code Section 667.5(c) lists the following “violent” felonies: murder; voluntary manslaughter; mayhem; rape; sodomy by force; oral copulation by force; lewd acts on a child under the age of 14 years; any felony punishable by death or imprisonment in the state prison for life; any felony in which the defendant inflicts great bodily injury on another; any robbery perpetrated in an inhabited dwelling; arson; penetration of a person’s genital or anal openings by foreign or unknown objects against the victim’s will; attempted murder; explosion or attempt to explode or ignite a destructive device or explosive with the intent to commit murder; kidnapping; continuous sexual abuse of a child; and carjacking.

Penal Code Section 1192.7 lists the following “serious” felonies: murder; voluntary manslaughter; mayhem; rape; sodomy by force; oral copulation by force; a lewd or lascivious act on a child under the age of 14 years; any felony punishable by death or imprisonment in the state prison for life; any felony in which the defendant personally inflicts great bodily injury on another, or in which the defendant personally uses a firearm; attempted murder; assault with intent to commit rape or robbery; assault with a deadly weapon on a peace officer; assault by a life prisoner on a noninmate; assault with a deadly weapon by an inmate; arson; exploding a destructive device with intent to injure or to murder, or explosion causing great bodily injury or mayhem; burglary of an inhabited dwelling; robbery or bank robbery; kidnapping; holding of a hostage by a person confined in a state prison; attempt to commit a felony punishable by death or imprisonment in the state prison for life; any felony in which the defendant personally uses a dangerous or deadly weapon; selling or furnishing specified controlled substances to a minor; penetration of genital or anal openings by foreign objects against the victim’s will; grand theft involving a firearm; carjacking; and a conspiracy to commit specified controlled substances offenses.

CERTIFICATION BY CONTRACTOR
CRIMINAL RECORDS CHECK
AB 1610, 1612 AND 2102

To the Governing Boards of Irvine Unified School District:

I, _____ certify that:
Name of Contractor

1. I have carefully read and understand the Notice Regarding Criminal Records Check (Education Code Section 45125.1) required by the passage of AB 1610, 1612 and 2102.
2. Due to the nature of the work I will be performing for the District, my employees may have contact with students of the District.
3. None of the employees who will be performing the work have been convicted of a violent or serious felony as defined in the Notice and in Penal Code Section 1192.7 and this determination was made by a fingerprint check through the Department of Justice.

I declare under penalty of perjury that the foregoing is true and correct.

Executed at _____, California on _____.
Date

Signature

Typed or printed name

Title

Address

Telephone

W-9 FORM

Current Version Available at: <http://www.irs.gov/pub/irs-pdf/fw9.pdf>

CHANGE ORDER NO.

(Additive)

PROJECT: **Lease of Relocatable Buildings, Bid No. 2026/27-1FA**

TO: _____

You are hereby directed to provide the extra work necessary to comply with this Change Order.

DESCRIPTION OF CHANGE:

COST (This cost shall not be exceeded.):

Original contract price: \$ _____
Change Order amount: \$ _____
New contract price: \$ _____

TIME FOR COMPLETION:

Original completion date: _____
Time for completion of
Change Order: _____
New completion date: _____

Contractor agrees to perform the above-described work in accordance with the above terms and in compliance with applicable sections of the Project Documents. The amount of the charges under this Change Order is limited to the charges allowed under Article 59 of the General Conditions. The adjustment in the contract sum, if any, and the adjustment in the contract time, if any, set out in this Change Order shall constitute the entire compensation and/or adjustment in the contract time due Contractor arising out of the change in the work covered by this Change Order, unless otherwise provided in this Change Order.

No additions or deletions to this Change Order shall be allowed, except with written permission of District. Contractor accepts the terms and conditions stated above as full and final settlement of any and all claims arising from this Change Order.

(continued on next page)

This Change Order is hereby agreed to, accepted and approved.

CONTRACTOR

DISTRICT

By: _____
Signature

By: _____
Signature

Print Name

Print Name

Title

Title

Date

Date

ARCHITECT

By: _____
Signature

Print Name

Title

Date

CHANGE ORDER NO.

(Deductive)

PROJECT: **Lease of Relocatable Buildings, Bid No. 2026/27-1FA**

TO: _____

You are hereby directed to comply with this Change Order.

DESCRIPTION OF CHANGE:

COST (This cost shall be deleted.):

Original contract price: \$ _____
Change Order amount: \$ _____
New contract price: \$ _____

TIME FOR COMPLETION:

Original completion date: _____
Time for completion of
Change Order: _____
New completion date: _____

Contractor agrees to deduct the above-described work in accordance with the above terms and in compliance with applicable sections of the Project Documents. Contractor agrees to the adjustment in the contract sum, if any, and the adjustment in the contract time, if any, set out in this Change Order.

No additions or deletions to this Change Order shall be allowed, except with written permission of District. Contractor accepts the terms and conditions stated above as full and final settlement of any and all claims arising from this Change Order.

(continued on next page)

This Change Order is hereby agreed to, accepted and approved.

CONTRACTOR

DISTRICT

By: _____
Signature

By: _____
Signature

Print Name

Print Name

Title

Title

Date

Date

ARCHITECT

By: _____
Signature

Print Name

Title

Date

GENERAL CONDITIONS (ATTACHED HERETO)

LEASE OF RELOCATABLE BUILDINGS, BID NO. 2026/27-1FA

TABLE OF CONTENTS TO THE GENERAL CONDITIONS

ARTICLE

1. DEFINITIONS
2. STATUS OF CONTRACTOR
3. CHANGE IN NAME AND NATURE OF CONTRACTOR'S LEGAL ENTITY
4. CONTRACTOR'S SUPERVISION, PROSECUTION AND PROGRESS
5. SUBCONTRACTORS
6. PROHIBITED INTERESTS
7. DISTRICT'S INSPECTOR
8. ARCHITECT'S STATUS
9. NOTICE OF TAXABLE POSSESSORY INTEREST
10. ASSIGNMENT OF ANTITRUST ACTIONS
11. OTHER CONTRACTS
12. OCCUPANCY
13. DISTRICT'S RIGHT TO TERMINATE AGREEMENT
14. BONDS
15. - NOT USED -
16. FIRE INSURANCE
17. PUBLIC LIABILITY AND PROPERTY DAMAGE INSURANCE
18. WORKERS' COMPENSATION INSURANCE
19. PROOF OF CARRIAGE OF INSURANCE
20. DRAWINGS AND SPECIFICATIONS
21. OWNERSHIP OF DRAWINGS
22. DETAIL DRAWINGS AND INSTRUCTIONS
23. SHOP DRAWINGS
24. LAYOUT AND FIELD ENGINEERING
25. SOILS INVESTIGATION REPORT
26. TESTS AND INSPECTIONS
27. TRENCHES
28. DOCUMENTS ON WORK
29. STATE AUDIT
30. SUBSTITUTIONS
31. SAMPLES
32. PROGRESS SCHEDULE
33. MATERIALS AND WORK
34. INTEGRATION OF WORK
35. OBTAINING OF PERMITS, LICENSES AND EASEMENTS
36. SURVEYS
37. EXISTING UTILITY LINES; REMOVAL, RESTORATION
38. WORK TO COMPLY WITH APPLICABLE LAWS AND REGULATIONS
39. ACCESS TO WORK
40. PAYMENTS BY CONTRACTOR

41. INSPECTOR'S FIELD OFFICE
42. UTILITIES
43. SANITARY FACILITIES
44. CLEANING UP
45. PATENTS, ROYALTIES, AND INDEMNITIES
46. GUARANTEE
47. DUTY TO PROVIDE FIT WORKERS
48. WAGE RATES, TRAVEL AND SUBSISTENCE
49. HOURS OF WORK
50. PAYROLL RECORDS
51. APPRENTICES
52. LABOR - FIRST AID
53. PROTECTION OF PERSONS AND PROPERTY
54. NON-DISCRIMINATION
55. SCHEDULE OF VALUES AND PERIODICAL ESTIMATES
56. CONTRACTOR CLAIMS
57. DISPUTES - ARCHITECT'S DECISIONS
58. PAYMENTS
59. CHANGES AND EXTRA WORK
60. COMPLETION
61. ADJUSTMENTS TO CONTRACT PRICE
62. CORRECTION OF WORK
63. EXTENSION OF TIME - LIQUIDATED DAMAGES
64. PAYMENTS WITHHELD
65. TAXES
66. NO ASSIGNMENT
67. NOTICE
68. NO WAIVER
69. NON-UTILIZATION OF ASBESTOS MATERIAL
70. LEAD
71. CRIMINAL RECORDS CHECK
72. DISABLED VETERAN BUSINESS ENTERPRISES
73. TOBACCO FREE POLICY
74. GOVERNING LAW
75. - NOT USED -

GENERAL CONDITIONS

ARTICLE 1. DEFINITIONS

- (a) Action of the Governing Board is a vote of a majority of the members in a lawful meeting.
- (b) Addenda are the changes in plans, specifications, drawings, and/or Project Documents which have been authorized in writing by the DISTRICT or ARCHITECT, and which alter, explain, or clarify the Project Documents prior to the bid deadline.
- (c) Approval means written authorization by ARCHITECT or DISTRICT.
- (d) Agreement includes collectively all Project Documents.
- (e) Project Documents includes collectively, to wit: Notice Calling for Bids, Calendar of Events, Information For Bidders, Bid Form, Bid Form Pricing Sheet, D.I.R Requirements for Contractors Working in a Public Works Contract, Bid Bond Form, Designation of Subcontractors, Equipment/Material Source Information, Information Required of Bidders, Noncollusion Declaration, Worker's Compensation Certificate, Certification of Primary Participant Regarding Debarment, Suspension & Other Related Matters, Certificate of Lobbying, Sample Agreement, Certificate of Liability Insurance, Faithful Performance Bond, Payment Bond, Contractor's Certificate Regarding Non-Asbestos Containing Materials, Disable Veteran Business Enterprises (DVBE), Guarantee, Drug-Free Workplace Certification, Tobacco Use Policy, Notice Regarding Criminal Records Check, Criminal Records Check Certification, W-9 Form, Change Order NO (ADDITIVE), Change Order NO (DEDUCTIVE), General Conditions, Special Condition, Drawings, specifications, and all modifications, addenda and amendments, if any (hereinafter Bid Documents), thereof duly incorporated therein. The Project Documents are complementary, and what is called for by any one shall be as binding as if called for by all.
- (f) CONTRACTOR or DISTRICT are those mentioned as such in the Agreement. They are treated throughout the Project Documents as if they are of singular number and neuter gender.
- (g) DISTRICT is the Governing Board or its duly authorized representative.
- (h) Locality in which the work is performed means the county and city in which the work is done.
- (i) Project is the planned undertaking as provided for in the Project Documents by DISTRICT and CONTRACTOR.
- (j) Provide shall include "provide complete in place," that is, "furnish and install."
- (k) Safety Orders are those issued by the Division of Industrial Safety and OSHA safety and health standards for construction.
- (l) Standards, Rules, and Regulations referred to are recognized printed standards and shall be considered as one and a part of these specifications within limits specified.
- (m) Subcontractor, as used herein, includes those having a direct contractual relationship with CONTRACTOR and one who furnishes material worked to a special design according to

plans, drawings, and specifications, but does not include one who merely furnishes material not so worked.

(n) Surety is the person, firm, or corporation that executes as a California admitted surety insurer, the CONTRACTOR's Bid Security, faithful performance bond and payment bond.

(o) Work of the CONTRACTOR or subcontractor includes labor or materials (including, without limitation, equipment and appliances) or both, incorporated in, or to be incorporated in the Project.

(p) Workers include laborer, worker, or mechanic.

ARTICLE 2. STATUS OF CONTRACTOR

(a) CONTRACTOR is and shall at all times be deemed to be an independent contractor and shall be wholly responsible for the manner in which it performs the services required of it by the terms of the Project Documents. Nothing herein contained shall be construed as creating the relationship of employer and employee, or principal and agent, between the DISTRICT and CONTRACTOR or any of CONTRACTOR's agents or employees. CONTRACTOR assumes exclusively the responsibility for the acts of its employees as they relate to the services to be provided during the course and scope of their employment. CONTRACTOR, its agents and employees shall not be entitled to any rights or privileges of DISTRICT employees and shall not be considered in any manner to be DISTRICT employees. DISTRICT shall be permitted to monitor the activities of the CONTRACTOR to determine compliance with the terms of the Project Documents.

(b) Contractors are required by law to be licensed and regulated by the Contractors' State License Board. Any CONTRACTOR not so licensed is subject to penalties under the law, and the contract will be considered void pursuant to Section 7028.7 of the Business and Professions Code. Any questions concerning a contractor may be referred to the Registrar, Contractors' State License Board, 9821 Business Park Drive, P. O. Box 26000, Sacramento, CA 95826.

ARTICLE 3. CHANGE IN NAME AND NATURE OF CONTRACTOR'S LEGAL ENTITY

Before CONTRACTOR makes any change in the name or legal nature of the CONTRACTOR's entity, CONTRACTOR shall first notify the DISTRICT in writing and cooperate with DISTRICT in making such changes as the DISTRICT may request in the Project Documents.

ARTICLE 4. CONTRACTOR'S SUPERVISION, PROSECUTION AND PROGRESS

(a) During progress of the work, CONTRACTOR shall keep on the work site a competent superintendent satisfactory to DISTRICT. Before commencing the work herein, CONTRACTOR shall give written notice to DISTRICT and ARCHITECT of the name, qualifications and experience of such superintendent. If Superintendent is found unsatisfactory by DISTRICT, CONTRACTOR shall replace the Superintendent with one acceptable to the DISTRICT. Superintendent shall not be changed except with written consent of DISTRICT, unless a superintendent proves to be unsatisfactory to CONTRACTOR and ceases to be in its employ, in which case, CONTRACTOR shall notify DISTRICT and ARCHITECT in writing and replace said Superintendent with one acceptable to the DISTRICT. Superintendent shall represent CONTRACTOR and all directions given to Superintendent shall be as binding as if given to CONTRACTOR.

(b) CONTRACTOR shall supervise and direct the work competently and efficiently, devoting such attention thereto and applying such skills as may be necessary to perform the work in

accordance with the Project Documents. CONTRACTOR shall carefully study and compare all plans, drawings, specifications, and other instructions and shall at once report to ARCHITECT any error, inconsistency or omission, which CONTRACTOR or its employees may discover. The CONTRACTOR represents itself to DISTRICT as a skilled, knowledgeable, and experienced CONTRACTOR. The CONTRACTOR shall carefully study and compare the Project Documents with each other, and shall at once report to the ARCHITECT any errors, inconsistencies, or omissions discovered. The CONTRACTOR shall be liable to the DISTRICT for damage resulting from errors, inconsistencies, or omissions in the Project Documents that the CONTRACTOR recognized and which CONTRACTOR knowingly failed to report and which a similarly skilled, knowledgeable, and experienced contractor would have discovered.

(c) The CONTRACTOR shall verify all indicated dimensions before ordering materials or equipment, or before performing work. The CONTRACTOR shall take field measurements, verify field conditions, and shall carefully compare such field measurements and conditions and other information known to the CONTRACTOR with the Project Documents before commencing work. Errors, inconsistencies or omissions discovered shall be reported to the DISTRICT at once. Upon commencement of any item of work, the CONTRACTOR shall be responsible for dimensions related to such item of work and shall make any corrections necessary to make work properly fit at no additional cost to DISTRICT. This responsibility for verification of dimensions is a non-delegable duty and may not be delegated to subcontractors or agents.

(d) Omissions from the plans, drawings or specifications, or the misdescription of details of work which are manifestly necessary to carry out the intent of the plans, drawings and specifications, or which are customarily performed, shall not relieve the CONTRACTOR from performing such omitted or misdescribed work, but they shall be performed as if fully and correctly set forth and described in the plans, drawings and specifications.

(e) The CONTRACTOR shall be solely responsible for the means, methods, techniques, sequences, and procedures of construction. The CONTRACTOR shall be responsible to see that the finished work complies accurately with the Project Documents.

ARTICLE 5. SUBCONTRACTORS

(a) CONTRACTOR agrees to bind every subcontractor by terms of the Project Documents as far as such terms are applicable to subcontractor's work. If CONTRACTOR shall subcontract any part of the work, CONTRACTOR shall be as fully responsible to DISTRICT for acts and omissions of any subcontractor and of persons either directly or indirectly employed by any subcontractor, as it is for acts and omissions of persons directly employed by CONTRACTOR. Nothing contained in Project Documents shall create any contractual relation between any subcontractor and DISTRICT, nor shall the contract documents be construed to be for the benefit of any subcontractor.

(b) DISTRICT's consent to any subcontractor shall not in any way relieve CONTRACTOR of any obligations under the Project Documents and no such consent shall be deemed to waive any provision of any Project Document.

(c) CONTRACTOR must submit with its bid, a Designation of Subcontractors pursuant to the Subletting and Subcontracting Fair Practices Act. If CONTRACTOR specifies more than one subcontractor for the same portion of work or fails to specify a subcontractor, and such portion of the work exceeds one-half of one percent of the total bid, CONTRACTOR agrees that it is fully qualified to perform and shall perform such work itself, unless CONTRACTOR provides for substitution or addition of subcontractors. Substitution or addition of subcontractors shall be

permitted only as authorized under the Subletting and Subcontracting Fair Practices Act, Public Contract Code Section 4100, et. seq.

(d) In accordance with Business and Professions Code Section 7059, if CONTRACTOR is designated as a "specialty contractor" (as defined in Section 7058 of the Public Contract Code), all of the work to be performed outside of the CONTRACTOR's license specialty shall be performed by a licensed subcontractor in compliance with the Subletting and Subcontracting Fair Practices Act, Public Contract Code Section 4100, et seq.

(e) A copy of each subcontract, if in writing, or, if not in writing, then a written statement signed by the CONTRACTOR giving the name of the subcontractor and the terms and conditions of such subcontract, shall be filed with the DISTRICT before the subcontractor begins work. Each subcontract shall contain a reference to the Agreement between the DISTRICT and the CONTRACTOR and the terms of that Agreement and all parts of the Project Documents shall be made a part of such subcontract insofar as applicable to the work covered thereby. Each subcontract will provide for termination in accordance with Article 13 of these General Conditions. Each subcontract shall provide for its annulment by the CONTRACTOR at the order of the ARCHITECT if in the ARCHITECT'S opinion the subcontractor fails to comply with the requirements of the Project Documents insofar as the same may be applicable to this work. Nothing herein contained shall relieve the CONTRACTOR of any liability or obligation hereunder.

ARTICLE 6. PROHIBITED INTERESTS

No official of DISTRICT who is authorized in such capacity and on behalf of DISTRICT to negotiate, make, accept, or approve, or to take part in negotiating, making, accepting or approving any architectural, engineering, inspection, construction or material supply contract or any subcontract in connection with construction of the Project, shall become directly or indirectly interested financially in this Project or in any part thereof. No officer, employee, architect, attorney, engineer or inspector of or for DISTRICT who is authorized in such capacity and on behalf of DISTRICT to exercise any executive, supervisory or other similar functions in connection with construction of Project shall become directly or indirectly interested financially in this Project or in any part thereof. CONTRACTOR shall receive no compensation and shall repay DISTRICT for any compensation received by CONTRACTOR hereunder, should CONTRACTOR aid, abet or knowingly participate in violation of this Article 6.

ARTICLE 7. DISTRICT'S INSPECTOR

(a) One or more Inspector(s), including special inspectors, as required, will be employed by DISTRICT and will be assigned to the Project.

(b) No work shall be performed by the CONTRACTOR solely upon the instructions or comments by the Inspector. The Inspector has no authority to interpret the Project Documents or order extra work and any extra work performed without the written instruction of the DISTRICT shall be at CONTRACTOR's sole cost and expense and there will be no delay damages incurred by DISTRICT for such work.

(c) No work shall be carried on except with the knowledge and under the inspection of said Inspector(s). He/she shall have free access to any or all parts of work at any time. CONTRACTOR shall furnish Inspector reasonable opportunities for obtaining such information as may be necessary to keep Inspector fully informed respecting progress and manner of work and character of materials. Inspection of work shall not relieve CONTRACTOR from any obligation to fulfill the Project Documents. Inspector or ARCHITECT shall have authority to stop work

whenever provisions of Project Documents are not being complied with and such noncompliance is discovered. CONTRACTOR shall instruct its employees accordingly.

(d) CONTRACTOR understands and agrees that the Inspector for the Project may also serve concurrently as inspector for other DISTRICT projects and may not therefore be available on site during the entire workday. It shall be the responsibility of CONTRACTOR to notify the Inspector not less than twenty-four (24) hours in advance of materials and equipment deliveries and required inspections.

ARTICLE 8. ARCHITECT'S STATUS

(a) The ARCHITECT shall be the DISTRICT's representative during construction and shall observe the progress and quality of the work on behalf of the DISTRICT. ARCHITECT shall have the authority to act on behalf of DISTRICT only to the extent expressly provided in the Project Documents. ARCHITECT shall have authority to stop work whenever such stoppage may be necessary in ARCHITECT'S reasonable opinion to ensure the proper execution of the Project Documents.

(b) The ARCHITECT shall be, in the first instance, the judge of the performance of the work. ARCHITECT shall exercise authority under the Project Documents to enforce CONTRACTOR's faithful performance.

(c) The ARCHITECT shall have all authority and responsibility established by law. The ARCHITECT has the authority to enforce compliance with the Project Documents and the CONTRACTOR shall promptly comply with instructions from the ARCHITECT or an authorized representative of the ARCHITECT.

(d) On all questions related to the quantities, the acceptability of material, equipment or workmanship, the execution, progress or sequence of work, the interpretation of plans, specifications or drawings, and the acceptable performance of the CONTRACTOR pursuant to the decision of the ARCHITECT shall govern and shall be precedent to any payment unless otherwise ordered by the Governing Board. The progress and completion of the work shall not be impaired or delayed by virtue of any question or dispute arising out of or related to the foregoing matters and the instructions of the ARCHITECT relating thereto.

(e) General supervision and direction of the work by the ARCHITECT shall in no way imply that the ARCHITECT or his or her representatives are in any way responsible for the safety of the CONTRACTOR or its employees or that the ARCHITECT or his or her representatives will maintain supervision over the CONTRACTOR's construction methods or personnel other than to ensure that the quality of the finished work is in accordance with the Project Documents.

ARTICLE 9. NOTICE OF TAXABLE POSSESSORY INTEREST

The terms of the Agreement may result in the creation of a possessory interest. If such a possessory interest is vested in a private party to the Agreement, the private party may be subjected to the payment of property taxes levied on such interest.

ARTICLE 10. ASSIGNMENT OF ANTITRUST ACTIONS

Public Contract Code Section 7103.5 provides:

In entering into a public works contract or a subcontract to supply goods, services, or materials pursuant to a public works contract, the contractor or subcontractor offers and agrees to assign to the awarding body (DISTRICT) all rights, title, and interest in and to all causes of action it may have under Section 4 of the Clayton Act (15 U.S.C. Section 15) or under the Cartwright Act (Chapter 2 (commencing with Section 16700) of Part 2 of Division 7 of the Business and Professions Code), arising from purchases of goods, services, or materials pursuant to the public works contract or the subcontract. This assignment shall be made and become effective at the time the awarding body tenders final payment to the contractor, without further acknowledgment by the parties.

CONTRACTOR, for itself and all subcontractors, agrees to assign to DISTRICT all rights, title, and interest in and to all such causes of action CONTRACTOR and all subcontractors may have under the Agreement. This assignment shall become effective at the time DISTRICT tenders final payment to the CONTRACTOR and CONTRACTOR shall require assignments from all subcontractors to comply herewith.

ARTICLE 11. OTHER CONTRACTS

(a) DISTRICT reserves the right to let other contracts in connection with this work. CONTRACTOR shall afford other contractors reasonable opportunity for introduction and storage of their materials and execution of their work and shall properly connect and coordinate its work with such other contractors.

(b) If any part of CONTRACTOR's work depends for proper execution or results upon work of any other contractor, the CONTRACTOR shall inspect and promptly report to ARCHITECT in writing any defects in such work that render it unsuitable for such proper execution and results. CONTRACTOR will be held accountable for damages to DISTRICT for that work which it failed to inspect or should have inspected. CONTRACTOR's failure to inspect and report shall constitute its acceptance of other contractor's work as fit and proper for reception of its work, except as to defects which may develop in other contractors' work after execution of CONTRACTOR's work.

(c) To ensure proper execution of its subsequent work, CONTRACTOR shall measure and inspect work already in place and shall at once report to the ARCHITECT in writing any discrepancy between executed work and Project Documents.

(d) CONTRACTOR shall ascertain to its own satisfaction the scope of the Project and nature of any other contracts that have been or may be awarded by DISTRICT in prosecution of the Project to the end that CONTRACTOR may perform this Agreement in the light of such other contracts, if any.

(e) Nothing herein contained shall be interpreted as granting to CONTRACTOR exclusive occupancy at site of Project. CONTRACTOR shall not cause any unnecessary hindrance or delay to any other contractor working on Project. If simultaneous execution of any contract for Project is likely to cause interference with performance of some other contract or contracts, DISTRICT shall decide which contractor shall cease work temporarily and which contractor shall continue or whether work can be coordinated so that contractors may proceed simultaneously.

(f) DISTRICT shall not be responsible for any damages suffered or extra costs incurred by CONTRACTOR resulting directly or indirectly from award or performance or attempted performance of any other contract or contracts on Project, or caused by any decision or omission of DISTRICT respecting the order of precedence in performance of contracts.

ARTICLE 12. OCCUPANCY

DISTRICT reserves the right to occupy buildings and/or portions of the site at any time before completion, and such occupancy shall not constitute final acceptance of any part of work covered by this Agreement, nor shall such occupancy extend the date specified for completion of the work. Beneficial occupancy of building(s) does not commence any warranty period nor shall it entitle CONTRACTOR to any additional compensation due to such occupancy.

ARTICLE 13. DISTRICT'S RIGHT TO TERMINATE AGREEMENT

(a) Termination for Cause. If the CONTRACTOR refuses or fails to complete the work or any separable part thereof with such diligence as will insure its completion within the time specified or any extension thereof, or fails to complete said work within such time, or if the CONTRACTOR should file a petition for relief as a debtor, or should relief be ordered against CONTRACTOR as a debtor under Title 11 of the United States Code, or if CONTRACTOR should make a general assignment for the benefit of its creditors, or if a receiver should be appointed on account of its insolvency, or if it should refuse or should fail to supply enough properly skilled workers or proper equipment, tools, and materials in the necessary quantity and quality to complete the work in the time specified, or if CONTRACTOR should fail to make prompt payment to subcontractors for materials or labor, or disregard laws or ordinances or instructions of DISTRICT, or if CONTRACTOR or its subcontractors should otherwise be guilty of a violation of any provision of this Agreement, then CONTRACTOR shall be deemed to be in default of the Agreement and DISTRICT may, without prejudice to any other right or remedy, serve written notice upon CONTRACTOR and its surety of DISTRICT's intention to terminate this Agreement, such notice to contain the reasons for such intention to terminate, and unless within ten (10) calendar days after the service of such notice such condition shall cease or such violation shall cease, or arrangements satisfactory to DISTRICT for the correction thereof be made and corrective action commenced in a diligent and workmanlike manner and pursued to satisfactory completion, this Agreement shall upon the expiration of said ten (10) calendar days, cease and terminate. In such case, CONTRACTOR shall be excluded from the worksite and not be entitled to receive any further payment until work is finished to DISTRICT's satisfaction.

(b) In the event of any such termination, surety shall have the right to take over and perform this Agreement, provided, however, that if surety within five (5) calendar days after service upon it of said notice of termination does not give DISTRICT written notice of its intention to take over and perform this Agreement or does not commence performance thereof within ten (10) calendar days after date of serving such notice of termination by DISTRICT on surety, DISTRICT may take over the work and prosecute same to completion by any means determined by DISTRICT including hiring another contractor for the account and at the expense of CONTRACTOR, and CONTRACTOR and its surety shall be liable to DISTRICT for any excess cost or other damages occasioned by the DISTRICT thereby. Time is of the essence in this Agreement. If the DISTRICT takes over the work as hereinabove provided, the DISTRICT may, without liability for so doing, take possession of and utilize in completing the work such materials, supplies, equipment and other property belonging to the CONTRACTOR as may be on the site of the work and necessary therefore.

(c) The expense of finishing the work, including compensation for additional architectural, managerial, and administrative services, shall be a charge against CONTRACTOR and CONTRACTOR agrees that the charge may be deducted from any money due or becoming due to CONTRACTOR from DISTRICT or CONTRACTOR shall pay the charge to the DISTRICT. Expense incurred by DISTRICT as herein provided, and damage incurred through CONTRACTOR's default, shall be certified to DISTRICT by ARCHITECT. The surety shall become liable for payment should CONTRACTOR fail to pay in full any cost incurred by the DISTRICT.

(d) Nonappropriation of Funds/Insufficient Funds. In the event that sufficient funds are not appropriated to complete the Project or the DISTRICT determines that sufficient funds are not available to complete the Project, DISTRICT may terminate or suspend the completion of the Project at any time by giving written notice to the CONTRACTOR. In the event that the DISTRICT exercises this option, the DISTRICT shall pay for any and all work and materials completed or delivered onto the site, and the value of any and all work then in progress and orders actually placed which cannot be canceled up to the date of notice of termination. The value of work and materials paid for shall include a factor of fifteen percent (15%) for the CONTRACTOR's overhead and profit and there shall be no other costs or expenses paid to CONTRACTOR. All work, materials and orders paid for pursuant to this provision shall become the property of the DISTRICT. DISTRICT may, without cause, order CONTRACTOR in writing to suspend, delay or interrupt the Project in whole or in part for such period of time as DISTRICT may determine. Adjustment shall be made for increases in the cost of performance of the Agreement caused by suspense, delay or interruption.

(e) The foregoing provisions are in addition to and not a limitation of any other rights or remedies available to the DISTRICT.

ARTICLE 14. BONDS

Unless otherwise specified in Special Conditions, CONTRACTOR shall furnish a surety bond in an amount equal to one hundred percent (100%) of total quotation price on each separate purchase order issued exceeding twenty-five thousand dollars (\$25,000) as security for faithful performance of this Agreement and shall furnish a separate bond in an amount of one hundred

percent (100%) of the total quotation price on each separate purchase order issued exceeding twenty-five thousand dollars (\$25,000) as security for payment to persons performing labor and furnishing materials in connection with this Project. Bonds shall be in the form set forth in these Project Documents.

ARTICLE 15. NOT USED

ARTICLE 16. FIRE INSURANCE

CONTRACTOR will procure at CONTRACTOR's own expense and before commencement of any work under this Agreement, fire insurance on the Project. Amount of fire insurance shall be sufficient to protect against loss or damage in full until work is accepted by DISTRICT. CONTRACTOR shall submit proof of insurance and shall provide endorsements on forms provided by the DISTRICT or on forms approved by the DISTRICT.

ARTICLE 17. PUBLIC LIABILITY AND PROPERTY DAMAGE INSURANCE

(a) CONTRACTOR shall take out and maintain during the life of this Agreement such public liability and property damage insurance as shall protect CONTRACTOR and DISTRICT from all claims for personal injury, including accidental death, to any person (including, as to DISTRICT, injury or death to CONTRACTOR's or subcontractor's employees), as well as from all claims for property damage arising from operations under this Agreement, in amounts as set forth in the Agreement.

(b) CONTRACTOR shall require its subcontractors, if any, to take out and maintain similar public liability and property damage insurance in like amounts or insure the activities of its subcontractors in CONTRACTOR's own policy.

(c) CONTRACTOR, during the progress of the work and until final acceptance of the work by DISTRICT upon completion of the entire Agreement, shall maintain Builder's Risk/ "All Risk," course-of-construction insurance in an amount not less than as set forth in the Agreement. Coverage is to provide extended coverage and insurance against vandalism, malicious mischief, perils of fire, sprinkler leakage, civil authority, sonic boom, earthquake, collapse, flood, wind, lightning, smoke, riot, debris removal (including demolition), and reasonable compensation for ARCHITECT's services and expenses required as a result of such insured loss upon the entire work which is the subject of the Project Documents, including completed work and work in progress to the full insurable amount thereof. The risk of damage to the work due to the perils covered by the Builder's Risk/"All Risk" Insurance, as well as any other hazards which might result in damage to the work, is that of CONTRACTOR and the surety, and no claims for such loss or damage shall be recognized by DISTRICT nor will such loss or damage excuse the complete and satisfactory performance of the Agreement by CONTRACTOR.

(d) CONTRACTOR shall submit proof of insurance and shall provide endorsements on the forms provided by the DISTRICT or on forms approved by the DISTRICT. Such insurance shall be issued by admitted surety insurers under the same conditions as required for bonds on the Project.

ARTICLE 18. WORKERS' COMPENSATION INSURANCE

(a) In accordance with the provisions of Section 3700 of the Labor Code, the CONTRACTOR and every subcontractor shall be required to secure the payment of compensation to its employees.

(b) The CONTRACTOR shall provide, during the life of the Agreement, workers' compensation insurance for all of its employees engaged in work under this Agreement, on or at the site of the Project, and, in case any of its work is sublet, the CONTRACTOR shall require the subcontractor similarly to provide workers' compensation insurance for all the latter's employees. Any class of employee or employees not covered by a subcontractor's insurance shall be covered by the CONTRACTOR's insurance. In case any class of employees engaged in work under this Agreement, on or at the site of the Project, is not protected under the workers' compensation statute, the CONTRACTOR shall provide or shall cause a subcontractor to provide, adequate insurance coverage for the protection of such employees not otherwise protected before subcontractor commences work. The CONTRACTOR shall file with the DISTRICT certificates of its insurance protecting workers and a thirty (30) day notice shall be provided to DISTRICT before the cancellation or reduction of any policy of CONTRACTOR or subcontractor. CONTRACTOR shall submit proof of insurance and shall provide endorsements on the forms provided by the DISTRICT or on forms approved by the DISTRICT. Such endorsements shall be submitted concurrently with the Project Documents.

ARTICLE 19. PROOF OF CARRIAGE OF INSURANCE

(a) CONTRACTOR shall not commence work nor shall it allow any subcontractor to commence work under this Agreement until all required insurance certificates and endorsements from admitted surety insurers have been obtained and delivered in duplicate to and approved by DISTRICT. Such insurance shall be issued by admitted surety insurers under the same conditions as required for bonds on the Project. CONTRACTOR shall provide proof of insurance on DISTRICT approved forms without revisions.

(b) Certificates and insurance policies shall include the following:

(1) A clause stating:

"This policy shall not be canceled or reduced in required limits of liability or amount of insurance until notice has been mailed to DISTRICT stating date of cancellation or reduction. Date of cancellation or reduction may not be less than thirty (30) days after date of mailing notice."

(2) Language stating in particular those insured, extent of insurance, location and operation to which insurance applies, expiration date, to whom cancellation and reduction notice will be sent, and length of notice period.

(3) Statement that the DISTRICT is an additional insured under the policy described and that such insurance policy shall be primary to any insurance or self-insurance maintained by the DISTRICT.

(c) In case of CONTRACTOR's failure to provide insurance as required by the Agreement, the DISTRICT may, at DISTRICT's option, take out and maintain at the expense of the CONTRACTOR, such insurance in the name of CONTRACTOR, or subcontractor, as the DISTRICT may deem proper and may deduct the cost of taking out and maintaining such insurance from any sums which are due or to become due to the CONTRACTOR under this Agreement.

ARTICLE 20. DRAWINGS AND SPECIFICATIONS

(a) Drawings and Specifications are intended to delineate and describe the Project and its component parts to such a degree as will enable skilled and competent contractors to intelligently bid upon the work, and to carry said work to a successful conclusion.

(b) Drawings and Specifications are intended to comply with all laws, ordinances, rules and regulations of constituted authorities having jurisdiction, and where referred to in the Project Documents, said laws, ordinances, rules and regulations shall be considered as a part of the Agreement within the limits specified. The CONTRACTOR shall bear all expenses of correcting work done contrary to said laws, ordinances, rules and regulations and if the CONTRACTOR performed same (1) without first consulting the ARCHITECT for further instructions regarding said work, or (2) disregarded the ARCHITECT'S instructions regarding said work.

(c) Questions regarding interpretation of drawings and specifications shall be clarified by the ARCHITECT. Before commencing any portion of the work, CONTRACTOR shall carefully examine all drawings and specifications and other information given to CONTRACTOR. CONTRACTOR shall immediately notify ARCHITECT and DISTRICT in writing of any perceived or alleged error, inconsistency, ambiguity, or lack of detail or explanation in the drawings and specifications. If CONTRACTOR or its subcontractors, material or equipment suppliers, or any of their officers, agents, and employees performs, permits, or causes the performance of any work under the Project Documents, which it knows or should have known to be in error, inconsistent, or ambiguous, or not sufficiently detailed or explained, CONTRACTOR shall bear any and all costs arising therefrom including, without limitation, the cost of correction thereof. In the event ARCHITECT determines that CONTRACTOR's requests for clarification or interpretation are not justified or do not reflect adequate competent supervision or knowledge by the CONTRACTOR or his/her subcontractors, CONTRACTOR shall be required to pay ARCHITECT's reasonable and customary fees in processing and responding to such requests. Should the CONTRACTOR commence work or any part thereof without seeking clarification, CONTRACTOR waives any claim for extra work or damages as a result of any ambiguity, conflict or lack of information.

(d) Figured dimensions on drawings shall govern, but work not dimensioned shall be as directed. Work not particularly shown or specified shall be the same as similar parts that are shown or specified. Large-scale drawings shall take precedence over smaller scale drawings as to shape and details of construction. Specifications shall govern as to materials, workmanship, and installation procedures. Drawings and specifications are intended to be fully cooperative and to agree. If CONTRACTOR observes that drawings and specifications are in conflict, CONTRACTOR shall promptly notify the ARCHITECT in writing, and any necessary changes shall be adjusted as provided in the Article entitled "Changes and Extra Work;" provided, however, that the specification calling for the higher quality material or workmanship shall prevail without additional cost to DISTRICT.

(e) Materials or work described in words which so applied has a well-known technical or trade meaning shall be deemed to refer to such recognized standards.

(f) It is not the intention of the Agreement to go into detailed descriptions of any materials and/or methods commonly known to the trade under "trade name" or "trade term." The mere mention or notation of such "trade name" or "trade term" shall be considered a sufficient notice to CONTRACTOR that it will be required to complete the work so named with all its incidental and accessory items according to the best practices of the trade.

(g) The naming of any material and/or equipment shall mean furnishing and installing of same, including all incidental and accessory items thereto and/or labor necessary to achieve full and complete functioning of the material and/or equipment as per best practices of the trade(s) involved, unless specifically noted otherwise.

(h) ARCHITECT will furnish to CONTRACTOR one (1) complete set of blue-line prints for posting of changes. Additional blue-line prints shall be provided by ARCHITECT upon payment by CONTRACTOR. During the construction period, CONTRACTOR shall maintain the set of blue-line prints in a satisfactory record condition, and shall thoroughly and neatly post, as they occur, all additions, deletions, corrections and/or revisions in the actual construction of the Project. The record drawings must be posted monthly and be current prior to each submission of each certificate of payment.

ARTICLE 21. OWNERSHIP OF DRAWINGS

All plans, drawings, designs, specifications, and other incidental architectural and engineering work or materials and other Project Documents and copies thereof furnished by DISTRICT are DISTRICT's property. They are not to be used in other work and are to be returned to DISTRICT on request at completion of work, and may be used by DISTRICT as it may require, without any additional costs to DISTRICT.

ARTICLE 22. DETAIL DRAWINGS AND INSTRUCTIONS

(a) In case of ambiguity, conflict, or lack of information, ARCHITECT shall furnish additional instructions by means of drawings or otherwise, necessary for proper execution of work. All such drawings and instructions shall be consistent with Project Documents, true developments thereof, and reasonably inferable therefrom. Such additional instructions shall be furnished with reasonable promptness, provided that CONTRACTOR informs the ARCHITECT of the relationship of the request to the critical path of construction.

(b) Work shall be executed in conformity therewith and CONTRACTOR shall do no work without proper drawings and instructions.

(c) The ARCHITECT will furnish necessary additional details to more fully explain the work, which details shall be considered as part of the Project Documents.

(d) Should any details be more elaborate, in the opinion of the CONTRACTOR, than scale drawings and specifications warrant, CONTRACTOR shall give written notice thereof to the ARCHITECT within five (5) days of the receipt of same. In case no notice is given to the ARCHITECT within five (5) days, it will be assumed the details are reasonable development of the scale drawings. In case notice is given, then it will be considered, and if found justified, the ARCHITECT will either modify the drawings or shall recommend to DISTRICT a change order for the extra work involved.

(e) All parts of the described and shown construction shall be of the best quality of their respective kinds and the CONTRACTOR is hereby advised to use all diligence to become fully

involved as to the required construction and finish, and in no case to proceed with the different parts of the work without obtaining first from the ARCHITECT such directions and/or drawings as may be necessary for the proper performance of the work.

(f) If it is found at any time, before or after completion of the work, that the CONTRACTOR has varied from the drawings and/or specifications, in materials, quality, form or finish, or in the amount or value of the materials and labor used, the ARCHITECT shall make a recommendation: (1) that all such improper work should be removed, remade and replaced, and all work disturbed by these changes be made good at the CONTRACTOR's expense; or (2) that the DISTRICT deduct from any amount due CONTRACTOR, the sum of money equivalent to the difference in value between the work performed and that called for by the drawings and specifications. ARCHITECT shall determine such difference in value. The DISTRICT, at its option, may pursue either recommendation made by the ARCHITECT.

ARTICLE 23. SHOP DRAWINGS

(a) CONTRACTOR shall check and verify all field measurements and shall submit to ARCHITECT within ten (10) business days of the date specified on the Notice to Proceed six (6) copies, checked and approved by CONTRACTOR, of all shop or setting list drawings, schedules, and materials list required for the work of various trades. ARCHITECT shall review such drawings, schedules and materials list only for conformance with design concept of Project and compliance with information given in Project Documents, and return as approved or disapproved with guidance as to required corrections within ten (10) business days. CONTRACTOR shall make any corrections required by ARCHITECT, file six (6) corrected copies with ARCHITECT, and furnish such other copies as may be needed for construction within three (3) business days. ARCHITECT'S approval of such drawings, schedules, or materials list shall not relieve CONTRACTOR from responsibility for deviations unless CONTRACTOR has in writing called ARCHITECT'S attention to such deviations at time of submission and secured ARCHITECT'S written approval, nor shall it relieve CONTRACTOR from responsibility for errors in shop drawings or schedules.

(b) All submittals of shop drawings, catalog cuts, data sheets, schedules and material lists shall be complete and shall conform to contract drawings and specifications.

(c) The term "shop drawing" as used herein shall be understood to include, but not be limited to, detail design calculations, fabrication and installation drawings, lists, graphs and operating instructions.

(d) Shop drawings shall be submitted at a time sufficiently early to allow review of same by the Division of State Architect (DSA) if required, and the ARCHITECT, and to accommodate the rate of construction progress required under the Project Documents. CONTRACTOR will be required to pay ARCHITECT's reasonable and customary fees in order to expedite review of shop drawings, which are not submitted in a timely fashion.

(e) All shop drawing submittals shall be accompanied by an accurately completed transmittal form using the format bound herein. Any shop drawing submittal not accompanied by such a form, or where all applicable items on the form are not completed, will be returned for resubmittal. The CONTRACTOR may authorize a material or equipment supplier to deal directly with the ARCHITECT with regard to shop drawings, however, ultimate responsibility for the accuracy and completeness of the information contained in the submittal shall remain with the CONTRACTOR.

(f) Normally, a separate transmittal form shall be used for each specific item or class of material or equipment for which a submittal is required. Transmittal of shop drawings on various

items using a single transmittal form will be permitted only when the items taken together constitute a manufacturer's "package" or are so functionally related that expediency indicates review of the group or package as a whole. At its option, the CONTRACTOR or Supplier may obtain from the ARCHITECT quantities of the shop drawing transmittal form at reproduction cost.

- (g) CONTRACTOR's review and approval of shop drawings shall include the following stamp:
"The CONTRACTOR has reviewed and approved not only the field dimensions but the construction criteria and has also made written notation regarding any information in the shop drawings that does not conform to the Project Documents. This shop drawing has been coordinated with all other shop drawings received to date by CONTRACTOR and this duty of coordination has not been delegated to subcontractors, material suppliers, the ARCHITECT, or the engineers on this project.

Signature of CONTRACTOR"

- (h) Within ten (10) business days after receipt of shop drawings, the ARCHITECT will return one or more prints of each drawing to CONTRACTOR with his or her comments noted thereon. The CONTRACTOR shall make a complete and acceptable submittal to the ARCHITECT by the second submission of drawings. The DISTRICT shall withhold funds due the CONTRACTOR to cover additional costs of the ARCHITECT'S review beyond the second submission and any other costs incurred by DISTRICT.

- (i) If prints of the shop drawing are returned to the CONTRACTOR marked "NO EXCEPTIONS TAKEN," formal revision of said drawing will not be required. If prints of the drawing are returned to the CONTRACTOR marked "MAKE CORRECTIONS NOTED," formal resubmittal of said drawings will not be required. If prints of the drawing are returned to the CONTRACTOR marked "REVISE AND RESUBMIT," the CONTRACTOR shall revise said drawing and shall resubmit six (6) copies of the revised drawing to the ARCHITECT. If prints of the drawing are returned to the CONTRACTOR marked "REJECTED RESUBMIT," the CONTRACTOR shall resubmit six (6) new copies of the drawing to the ARCHITECT.

- (j) Fabrication of an item shall not be commenced before the ARCHITECT has reviewed the pertinent shop drawings and returned copies to the CONTRACTOR marked with "NO EXCEPTIONS TAKEN," or "MAKE CORRECTIONS NOTED." Revisions indicated on shop drawings shall be considered as changes necessary to meet the requirements of the Project Documents and shall not be taken as the basis of claims for extra work. The review of such drawings by the ARCHITECT will be limited to checking for general agreement with the Project Documents, and shall in no way relieve the CONTRACTOR of responsibility for errors or omissions contained therein, nor shall such review operate to waive or modify any provision contained in the Project Documents. Fabricating dimensions, quantities of material, applicable code requirements, and other contract requirements shall be the CONTRACTOR's responsibility.

- (k) No work represented by required shop drawings shall be purchased or commenced until the applicable submittal has been approved. The work shall conform to the approved shop drawings and all other requirements of the Project Documents. The CONTRACTOR shall not proceed with any related work, which may be affected by the work covered under shop drawings until the applicable shop drawings have been approved, particularly where piping, machinery, and equipment and the required arrangements and clearances are involved.

(l) Except where the preparation of a shop drawing is dependent upon the approval of a prior shop drawing, all shop drawings pertaining to the same class or portion of the work shall be submitted simultaneously.

(m) Calculations of a structural nature must be approved by the Division of State Architect.

(n) THE CONTRACTOR SHALL HAVE NO CLAIM FOR DAMAGES OR EXTENSION OF TIME DUE TO ANY DELAY RESULTING FROM THE CONTRACTOR HAVING TO MAKE THE REQUIRED REVISIONS TO SHOP DRAWINGS UNLESS REVIEW BY THE ARCHITECT OF SAID DRAWINGS IS DELAYED BEYOND THE TIME PROVIDED HEREINBEFORE AND THE CONTRACTOR CAN ESTABLISH THAT THE ARCHITECT'S DELAY IN REVIEW ACTUALLY RESULTED IN A DELAY IN THE CONTRACTOR CONSTRUCTION SCHEDULE. CONTRACTOR SHALL NOT BE ENTITLED TO ANY CLAIM FOR DAMAGES RESULTING FROM DSA REVIEW EXTENDING BEYOND FIFTEEN (15) CALENDAR DAYS AFTER SUBMITTAL. HOWEVER, DISTRICT MAY CONSIDER AN EXTENSION OF TIME DUE TO ANY DELAY CAUSED BY DSA REVIEW.

ARTICLE 24. LAYOUT AND FIELD ENGINEERING

All field engineering required for laying out of this work and establishing grades for earthwork operations shall be furnished by CONTRACTOR at its expense. The DISTRICT will provide field survey as indicated in Article 36

ARTICLE 25. SOILS INVESTIGATION REPORT

(a) When a soils investigation report has been obtained from test holes at the site, such report is available for the CONTRACTOR's use in preparing its bid and work under this Agreement. Such report shall not be part of the Agreement. Any information obtained from such report or any information given on drawings as to surface and subsurface soil condition or to elevations of existing grades or elevations of underlying rock is approximate only, is not guaranteed and does not form a part of the Agreement. CONTRACTOR is required to make a visual examination of site and must make whatever test CONTRACTOR deems appropriate to determine surface and subsurface soil conditions. If, during the course of work under this Agreement, CONTRACTOR encounters subsurface or latent conditions which differ materially from those indicated in the soils investigation report, then CONTRACTOR shall notify the DISTRICT within five (5) working days of discovery of the condition.

WARNING: DISTRICT DOES NOT WARRANT THE SOILS AT THE PROJECT SITE NOR ANY INFORMATION CONTAINED IN ANY SOILS REPORT. SOILS INVESTIGATION REPORT IS PROVIDED FOR CONTRACTOR'S INFORMATION ONLY. CONTRACTOR HAS CONDUCTED AN INDEPENDENT INVESTIGATION OF THE PROJECT SITE AND THE SOILS CONDITIONS OF THE SITE. DISTRICT DOES NOT WARRANT THE SOILS CONDITIONS OF THE SITE AND CONTRACTOR IS FULLY RESPONSIBLE TO ASCERTAIN SITE CONDITIONS FOR THE PURPOSES OF DETERMINING CONSTRUCTION MEANS AND METHODS PRIOR TO COMMENCING CONSTRUCTION.

(b) CONTRACTOR agrees that no claim against DISTRICT will be made by CONTRACTOR for damages and hereby waives any rights to damages in the event that during progress of work CONTRACTOR encounters subsurface or latent conditions at the worksite materially different from those shown on drawings or indicated in specifications.

ARTICLE 26. TESTS AND INSPECTIONS

- (a) Tests and inspections will comply with California Code of Regulations and with all other laws, ordinances, rules, regulations, or orders of public authorities having jurisdiction over the Project.
- (b) If the Agreement, DISTRICT's instructions, laws, ordinances, or any public authority require any work to be specially tested or approved, CONTRACTOR shall give notice in accordance with such authority of its readiness for observation or inspection at least two (2) working days prior to being tested or covered up. If inspection is by authority other than DISTRICT, CONTRACTOR shall inform the DISTRICT's Inspector of the date fixed for such inspection. Required certificates of inspection shall be secured by CONTRACTOR. Observations by DISTRICT's Inspector shall be promptly made, and where practicable, at source of supply. If any work should be covered up without approval or consent of DISTRICT's Inspector, it must be uncovered for examination and satisfactorily reconstructed at CONTRACTOR's expense in compliance with the Agreement. Costs of tests, inspections and any materials found to be not in compliance with the Agreement shall be paid for by CONTRACTOR. Other costs for test and inspection shall be paid by the DISTRICT.

ARTICLE 27. TRENCHES

- (a) CONTRACTOR shall provide adequate sheeting, shoring, and bracing, or equivalent method, for the protection of life and limb in trenches and open excavation, which conform to applicable safety standards.
- (b) If this Agreement involves the excavation of any trench or trenches five (5) feet or more in depth, and the Project cost is in excess of \$25,000, the CONTRACTOR shall, in advance of excavation, submit to the DISTRICT for acceptance or to whomever DISTRICT designates which may include a registered civil or structural engineer employed by the DISTRICT to whom authority to accept has been delegated, a detailed plan showing the design of shoring, bracing, sloping or other provisions to be made for worker protection from the hazard of caving ground during the excavation of such trench or trenches. If such plan varies from the Shoring System Standards established by the Construction Safety Orders of the Division of Industrial Safety, the plan shall be prepared by a registered civil or structural engineer employed by the CONTRACTOR, and all costs therefore shall be included in the price named in the Agreement for completion of the work as set forth in the Project Documents. In no case shall such plan be less effective than that required by the Construction Safety Orders. No excavation of such trench or trenches shall be commenced until said plan has been accepted by CAL-OSHA and a CAL-OSHA permit for such plan delivered to the DISTRICT. Labor Code Section 6500 and 6705; Health and Safety Code Section 17922.5)
- (c) If this Agreement involves the digging of trenches or excavations that extend deeper than four feet below the surface, the following shall apply pursuant to Public Contract Code section 7104:

(1) The CONTRACTOR shall promptly, and before the following conditions are disturbed, notify the DISTRICT, in writing, of any:

(i) Material that the CONTRACTOR believes may be material that is hazardous waste, as defined in Section 25117 of the Health and Safety Code, that is required to be removed to a Class I, Class II, or Class III disposal site in accordance with provisions of existing law.

(ii) Subsurface or latent physical conditions at the site different from those indicated.

(iii) Unknown physical conditions at the site of any unusual nature, different materially from those ordinarily encountered and generally recognized as inherent in work of the character provided for in the contract.

(2) The DISTRICT shall promptly investigate the conditions, and if it finds that the conditions do materially so differ, or do involve hazardous waste, and cause a decrease or increase in the CONTRACTOR's cost of, or the time required for, performance of any part of the work shall issue a change order under the procedures described in the Project Documents.

(3) In the event a dispute arises between the DISTRICT and the CONTRACTOR, whether the conditions materially differ or involve hazardous waste, or cause a decrease or increase in the CONTRACTOR's cost of, or time required for, performance of any part of the work, the CONTRACTOR shall not be excused from any scheduled completion date provided for by the Project Documents, but shall proceed with all the work to be performed under the Project Documents. The CONTRACTOR shall retain any and all rights provided either by contract or by law, which pertain to the resolution of disputes and protests between the contracting parties.

ARTICLE 28. DOCUMENTS ON WORK

CONTRACTOR shall keep on the job site at all times one legible copy of all Project Documents, including addenda and change orders, and all approved drawings, plans, schedules and specifications. Said Documents shall be kept in good order and available to ARCHITECT, ARCHITECT's representatives, and all authorities having jurisdiction. CONTRACTOR shall be acquainted with and comply with all California Code of Regulations provisions relating to conditions on this Project.

ARTICLE 29. STATE AUDIT

Pursuant to and in accordance with the provisions of Government Code Section 8546.7, or any amendments thereto, all books, records and files of the DISTRICT, the CONTRACTOR, or any subcontractor connected with the performance of this Agreement involving the expenditure of public funds in excess of Ten Thousand Dollars (\$10,000.00), including, but not limited to, the costs of administration of the Agreement, shall be subject to the examination and audit of the State Auditor at the request of the DISTRICT or as part of any audit of the DISTRICT for a period of three (3) years after final payment is made under this Agreement .

ARTICLE 30. SUBSTITUTIONS

(a) Prior to Bid Opening. Should the bidder wish to request prior to bid opening, any substitution for the materials, process, service or equipment specified, the bidder shall submit a written request at least ten (10) working days before the bid opening date and hour. If the substituted item is acceptable, the DISTRICT will approve it in an Addendum issued to all bidders of record. Requests received less than ten (10) working days prior to bid opening will not be considered. DISTRICT shall only consider substitution requests from the bidder submitting the bid for the project.

(b) After Bid Opening and Prior to Award of Contract. If the bidder clearly indicates in its bid that it is proposing to use an “equal” product, the brand name or trade name, if any, of a proposed substitute item shall be inserted in the space provided in the bid or shall be otherwise clearly identified in the bid. If the bidder fails to indicate an “equal” product, its bid shall be considered as offering the material, process, service or equipment referred to by the brand name or trade name specified. It is expressly understood and agreed to by the bidder that the DISTRICT reserves the right to reject any such proposed substituted item. It is further expressly understood and agreed by bidder that in the event the DISTRICT rejects a proposed “equal” item, the bidder will then supply the material, process, service or equipment designated by brand name or trade name or a substitute therefore which meets with the approval of the DISTRICT.

With respect to all proposed substitutions of “equal” items, the bidder shall submit all pertinent and appropriate data substantiating its request for substitutions within five (5) days prior to the award of the contract. DISTRICT shall only consider substitution requests from the bidder submitting the bid for the Project. The DISTRICT is not responsible for locating or securing any information, which is not included in such substantiating data. The burden of proof as to the quality or suitability of proposed substituted items shall be borne by the bidder. The DISTRICT shall be the sole judge as to the quality and suitability of proposed substituted items, and decisions of the DISTRICT shall be final and conclusive. Unless extended by the mutual agreement of the parties, the DISTRICT shall notify the successful bidder of the decision concerning the proposed substitution of “equal” items prior to the award of the contract. In addition, such decisions by the DISTRICT shall be in writing, and no proposed substituted item shall be deemed approved unless the DISTRICT has so indicated in writing. These time limitations shall be complied with strictly, and in no case will an extension of time for completion be granted because of the bidder’s failure to request the substitution of an item at the times and in the manner set forth herein.

(c) Whenever in specifications any materials, process, service or equipment is indicated or specified by brand name, trade name, proprietary name or by name of manufacturer, such specification shall be deemed to be used for the purpose of facilitating description of material, process, service or equipment desired and shall be deemed to be followed by the words “or equal,” and CONTRACTOR may, unless otherwise stated, offer any material, process, service, or equipment which shall be substantially equal or better in every respect to that so indicated or specified subject to DISTRICT or ARCHITECT approval.

(d) If material, process, service, or equipment offered by CONTRACTOR is not, in opinion of ARCHITECT, or DISTRICT, substantially equal or better in every respect to that specified, then CONTRACTOR shall furnish the material, process, service, or equipment specified. Burden of proof as to equality of any material, process, service, or equipment shall rest with CONTRACTOR. Provision authorizing submission of "or equal" substantiating data shall not in any way authorize an extension of time for performance of this Agreement nor shall DISTRICT or ARCHITECT authorize the submission of "or equal" substantiating data within thirty (30) days of the filing of the Notice of Completion on the Project.

(e) In the event CONTRACTOR furnishes material, process, service or equipment other than what was specified by the DISTRICT and which has been accepted by the DISTRICT and which later is defective, then CONTRACTOR at its sole cost and expense shall furnish the DISTRICT specified material, process, service or equipment or fully replace with new the defective material process, service or equipment at DISTRICT's discretion.

(f) In the event CONTRACTOR furnishes material, process service, or equipment more expensive than that specified, difference in cost of such material, process, service, or equipment so furnished shall be borne by CONTRACTOR. Any engineering, design fees, or approval agencies' fees required to make adjustments in material or work of all trades directly or indirectly affected by the approved substituted items shall be borne entirely by CONTRACTOR. Any difference in cost between an approved substitution which is lower in cost than the originally specified item shall be refunded or credited by CONTRACTOR to DISTRICT.

(g) Price, fitness and quality being equal with regard to supplies, the District may prefer supplies grown, manufactured, or produced in California and next prefer supplies partially manufactured grown, or produced in California provided the bids of said suppliers or the prices quoted by them do not exceed by more than 5% of the lowest bids/prices quoted by out of state suppliers, the major portion of the manufacture of the supplies is not done outside of California and the public good will be served thereby. (Government Code section 4330-4334)

ARTICLE 31. SAMPLES

(a) CONTRACTOR shall furnish for approval, within ten (10) business days following award of contract, all samples as required in specifications together with catalogs and supporting data required by ARCHITECT. This provision shall not authorize any extension of time for performance of the work. ARCHITECT shall review such samples, as to conformance with design concept of work and for compliance with information given in Project Documents and approve or disapprove same within ten (10) working days from receipt of same.

(b) Unless specified otherwise, sampling, preparation of samples and tests shall be in accordance with the latest standards of the American Society for Testing and Materials.

(c) Samples shall, upon demand of ARCHITECT or DISTRICT, be submitted for tests or examinations and considered before incorporation of same into the work. CONTRACTOR shall be solely responsible for delays due to samples not being submitted in time to allow for tests. Acceptance or rejection will be expressed in writing. Work shall be equal to approved samples in

every respect. Samples, which are of value after testing, will remain the property of the CONTRACTOR.

ARTICLE 32. PROGRESS SCHEDULE

(a) Within five (5) calendar days after being awarded the contract, CONTRACTOR shall submit a progress schedule for DISTRICT's approval. The schedule shall indicate the beginning and completion dates of all phases of construction and shall use the "critical path method" (commonly called CPM) or equivalent scheduling methodology for the value reporting, planning and scheduling, of all work required under the Project Documents. The schedule will separately identify those milestones or events that must be completed before other portions of the work can be accomplished.

(b) The scheduling is necessary for the DISTRICT's adequate monitoring of the progress of the work and shall be prepared in accordance with the time frame described in Article 4 of the Agreement. The DISTRICT may disapprove such a schedule and require modification to it if, in the opinion of the ARCHITECT or DISTRICT, adherence to the progress schedule will cause the work not to be completed in accordance with the Agreement. CONTRACTOR shall adhere to any such modifications required by the DISTRICT.

(c) CONTRACTOR will exchange scheduling information with subcontractors and suppliers. CONTRACTOR will order work, equipment and materials with sufficient lead-time to avoid interruption of the work.

(d) The CONTRACTOR shall submit to DISTRICT a monthly schedule to reflect the actual sequence of the work which shall be totally separate and apart from the original progress schedule.

(e) The CONTRACTOR shall also, if requested by the ARCHITECT or DISTRICT, provide revised schedules within ten (10) calendar days if, at any time, the ARCHITECT or DISTRICT, consider the completion date to be in jeopardy. The revised schedule shall be designed to show how the CONTRACTOR intends to accomplish the work to meet the original completion date. The form and method employed by the CONTRACTOR shall be the same as for the original progress schedule. The CONTRACTOR shall modify any portions of the schedule that become infeasible because of "activities behind schedule" or for any other valid reason. CONTRACTOR will provide documents and justification for any schedule changes. An activity that cannot be completed by its original completion date shall be deemed to be behind schedule.

(f) CONTRACTOR shall submit a revised schedule within ten (10) consecutive calendar days of CONTRACTOR's request for any extension of time. Failure to submit such schedule will result in CONTRACTOR waiving his/her right to obtain any extension of time.

(g) IT IS AGREED THAT THE DISTRICT OWNS THE "FLOAT" ON THIS PROJECT. IF CONTRACTOR SUBMITS A REVISED SCHEDULE SHOWING AN EARLIER COMPLETION DATE FOR THE PROJECT, DISTRICT'S ACCEPTANCE OF THIS REVISED SCHEDULE SHALL NOT ENTITLE CONTRACTOR TO ANY DELAY CLAIM OR DISRUPTION DAMAGES OR ANY OTHER DAMAGES DUE TO ANY SUCH REVISED SCHEDULE. NOTHING PROVIDED HEREIN

SHALL BE CONSTRUED AS A DIRECT, INDIRECT OR IMPLICIT ACCELERATION ORDER TO THE CONTRACTOR.

(h) CONTRACTOR agrees that failure to timely submit the progress schedule, the monthly schedule or any revised progress schedule requested by the ARCHITECT or the DISTRICT may result in delay in payment to CONTRACTOR.

ARTICLE 33. MATERIALS AND WORK

(a) Except as otherwise specifically stated in this Agreement, CONTRACTOR shall provide and pay for all materials, supplies, tools, equipment, labor transportation, superintendence, temporary constructions of every nature, and all other services and facilities of every nature whatsoever necessary to execute and complete the Project within specified time.

(b) Unless otherwise specified, all materials shall be new and the best of their respective kinds and grades as noted or specified, and workmanship shall be of good quality.

(c) Materials shall be furnished in ample quantities and at such times as to insure uninterrupted progress of work and shall be stored properly and protected as required. DISTRICT has no obligation to pay for any prefabricated material stored offsite until delivered and installed to the jobsite and inspected and approved by the inspector of record.

(d) CONTRACTOR shall, after issuance of the Notice to Proceed by DISTRICT, place orders for materials and/or equipment as specified so that delivery of same may be made without delays to the work. CONTRACTOR shall, upon demand from the ARCHITECT, furnish to the ARCHITECT documentary evidence showing that orders have been placed.

(e) DISTRICT reserves the right, for any neglect in not complying with the above instructions, to place orders for such materials and/or equipment as it may deem advisable in order that the work may be completed at the date specified in the Agreement, and all expenses incidental to the procuring of said materials and/or equipment shall be paid for by the CONTRACTOR.

(f) No materials, supplies, or equipment for work under this Agreement shall be purchased subject to any chattel mortgage or under a conditional sale or other agreement by which an interest therein or in any part thereof is retained by seller or supplier. CONTRACTOR warrants good title to all material, supplies, and equipment installed or incorporated in work and agrees upon completion of all work to deliver premises, together with all improvements and appurtenances constructed or placed thereon by it, to DISTRICT free from any claims, liens, or charges. CONTRACTOR further agrees that neither it nor any person, firm, or corporation furnishing any materials or labor for any work covered by this Agreement shall have any right to lien upon premises or any improvement or appurtenance thereon, except that CONTRACTOR may install metering devices or other equipment of utility companies or of political subdivisions, title to which is commonly retained by utility company or political subdivision. In the event of installation of any such metering device or equipment, CONTRACTOR shall advise DISTRICT as to owner thereof.

(g) Nothing contained in this Article 33, however, shall defeat or impair the rights of persons furnishing material or labor under any bond given by CONTRACTOR for their protection or any

rights under any law permitting such persons to look to funds due CONTRACTOR in hand of DISTRICT, and this provision shall be inserted in all subcontracts and material contracts and notice of its provisions shall be given to all persons furnishing materials or labor when no formal contract is entered into for such materials or labor.

(h) The title to new materials and/or equipment and attendant liability for its protection and safety, shall remain in the CONTRACTOR until incorporated in the work and accepted by the DISTRICT; no part of said materials and/or equipment shall be removed from its place of onsite/offsite storage except for immediate installation in the work; and CONTRACTOR shall keep an accurate inventory of all said materials and/or equipment in a manner satisfactory to the DISTRICT or its authorized representative.

ARTICLE 34. INTEGRATION OF WORK

(a) CONTRACTOR shall do all cutting, fitting, patching, and preparation of work as required to make its several parts come together properly, and fit it to receive or be received by work of other contractors or existing conditions showing upon, or reasonably implied by, the drawings and specifications, and shall follow all directions given by the Architect.

(b) All costs caused by defective or ill-timed work shall be borne by CONTRACTOR.

(c) CONTRACTOR shall not endanger any work by cutting, excavating, or otherwise altering work and shall not cut or alter work of any other contractor without the written consent of the ARCHITECT. CONTRACTOR shall be solely responsible for protecting existing work on adjacent properties and shall obtain all required permits for shoring and excavations near property lines.

(d) When modifying existing work or installing new work adjacent to existing work, CONTRACTOR shall match, as closely as conditions of site and materials will allow, the finishes, textures, and colors of the original work, refinishing existing work as required, at no additional cost to DISTRICT.

(e) CONTRACTOR is aware that this Project may be split into several phases. If the Project is split into phases, then CONTRACTOR has made allowances for any delays or damages, which may arise from coordination with contractors for other phases. If any delays should arise from a contractor working on a different phase, CONTRACTOR's sole remedy for damages, including delay damages, shall be against the contractor who caused such damage and not the DISTRICT. CONTRACTOR shall provide access to contractors for other phases as necessary to prevent delays and damages to contractors working on other phases of construction.

ARTICLE 35. OBTAINING OF PERMITS, LICENSES AND EASEMENTS

(a) Permits, licenses, and certificates necessary for prosecution of work, shall be secured and paid for by CONTRACTOR, unless otherwise specified. All such permits, licenses, and certificates shall be delivered to the ARCHITECT before demand is made for the certificate of final payment. CONTRACTOR shall, and shall require subcontractors to, maintain contractors' licenses in effect as required by law.

(b) Easements for permanent structures or permanent changes in existing facilities shall be secured and paid for by DISTRICT, unless otherwise specified.

- (c) Permits and charges for installation, and inspection thereof, of utility services by serving utilities shall be secured and paid for by DISTRICT.

ARTICLE 36. SURVEYS

All required controls, line certifications, grade certifications and surveys to determine rough grading, finish grades, building corners and structures, water lines (domestic, fire and reclaimed), sewer lines, storm drain lines, catch basins, curb inlets, gas lines, electrical lines, curb, gutter, sidewalks, concrete flat work, planters tree wells, site improvements, site light pole bases, property lines, etc. will be supplied by DISTRICT. CONTRACTOR to supply “grade checkers” and other similar engineering control customary to the scope of work. Refer to Supplemental Conditions (if applicable) and Project Specifications for further clarification.

ARTICLE 37. EXISTING UTILITY LINES; REMOVAL, RESTORATION

- (a) Pursuant to Government Code Section 4215, the DISTRICT assumes the responsibility for removal, relocation, and protection of utilities located on the construction site at the time of commencement of construction under this Agreement with respect to any such utility facilities, which are not identified in the plans and specifications.

The CONTRACTOR shall not be assessed for liquidated damages for delay in completion of the Project caused by failure of the DISTRICT to provide for removal or relocation of such utility facilities. If the CONTRACTOR, while performing work under this Agreement, discovers utility facilities not identified by the DISTRICT in the plans or specifications, CONTRACTOR shall immediately notify the DISTRICT and the utility in writing. CONTRACTOR shall be compensated according to the provisions governing changes in the work.

- (b) This Article 37 shall not be construed to preclude assessment against the CONTRACTOR for any other delays in completion of the work. Nothing in this Article shall be deemed to require the DISTRICT to indicate the presence of existing service laterals or appurtenances whenever the presence of such utilities on the construction site can be inferred from the presence of other visible facilities, such as buildings, meter junction boxes, on or adjacent to the site of the construction.

- (c) As part of the work to be performed, CONTRACTOR shall provide the notices and proceed in accordance with Government Code Sections 4216.2, 4216.3 and 4216.4, and pay all fees charged pursuant to Government Code Section 4216, et seq.

ARTICLE 38. WORK TO COMPLY WITH APPLICABLE LAWS AND REGULATIONS

- (a) CONTRACTOR shall give all notices and comply with all laws, ordinances, rules, and regulations applicable to the work as indicated and specified.

- (b) If CONTRACTOR observes that drawings or specifications are at variance therewith, CONTRACTOR shall promptly notify ARCHITECT in writing and any changes deemed necessary by the ARCHITECT shall be adjusted as provided for changes in work. If CONTRACTOR performs any work which it knew, or through exercise of reasonable care should have known, to be contrary to such laws, ordinances, rules or regulations, and without such notice to ARCHITECT, CONTRACTOR shall bear all costs arising therefrom. Where plans, drawings or specifications state that materials, processes, or procedures must be approved by the Division of State Architect, State Fire Marshall, or other body or agency, CONTRACTOR shall be responsible for satisfying requirements of such bodies or agencies.

ARTICLE 39. ACCESS TO WORK

DISTRICT and its representatives shall at all times have access to work wherever it is in preparation or progress. CONTRACTOR shall provide safe and proper facilities for such access so that DISTRICT's representatives may perform their functions.

ARTICLE 40. PAYMENTS BY CONTRACTOR

CONTRACTOR shall pay:

- (1) For all transportation and utility services not later than the 20th day of the calendar month following that in which such services are rendered;
- (2) For all materials, tools, and other expendable equipment to the extent of ninety five percent (95%) of cost thereof, not later than the 20th day of the calendar month following that in which such materials, tools, and equipment are delivered at site of Project and balance of cost thereof not later than the 30th day following completion of that part of work in or on which such materials, tools, and equipment are incorporated or used; and
- (3) To each of its subcontractors, not later than the 5th day following each payment to CONTRACTOR the respective amounts allowed CONTRACTOR on account of work performed by respective subcontractor to the extent of such subcontractor's interest therein.
- (4) Within seven (7) days from the time that all or any portion of the retentions are received by CONTRACTOR from DISTRICT, to each of its subcontractors from whom retention has been withheld, each subcontractor's share of the retention received. However, if a retention payment received by CONTRACTOR is specifically designated for a particular subcontractor, payment of the retention shall be made to the designated subcontractor, if the payment is consistent with the terms of the subcontract. CONTRACTOR may withhold from a subcontractor its portion of the retentions if a bona fide dispute exists between the subcontractor and the CONTRACTOR. The amount withheld from the retention shall not exceed one hundred fifty percent (150%) of the estimated value of the disputed amount.

ARTICLE 41. INSPECTOR'S FIELD OFFICE

Inspector office to be provided by the District.

ARTICLE 42. UTILITIES

- (a) All utilities, including but not limited to electricity, water, gas, and telephone used on work shall be furnished and paid for by CONTRACTOR. CONTRACTOR shall furnish and install necessary temporary distribution systems, including meters, if necessary, from distribution points to points on site where utility is necessary to carry on the work. When it is necessary to interrupt any existing utility service to make connections, a minimum of forty-eight (48) hours advance notice shall be given to the DISTRICT and ARCHITECT. Interruptions in utility services shall be of the shortest possible duration for the work at hand and shall be approved by the DISTRICT and

the ARCHITECT. In the event any utility service is interrupted without the required forty-eight (48) hours' notice, then CONTRACTOR shall be liable for all damage suffered by DISTRICT due to the interruption. Upon completion of work, CONTRACTOR shall remove all temporary distribution systems.

(b) CONTRACTOR may, with written permission of DISTRICT, use DISTRICT's existing utilities by making prearranged payments to DISTRICT for utilities used by CONTRACTOR for the Project.

ARTICLE 43. SANITARY FACILITIES

The DISTRICT shall provide sanitary temporary toilet facilities in no fewer numbers than required by law and such additional facilities as may be directed by the Inspector for the use of all workers. The toilet facilities shall be maintained in a sanitary condition at all times and shall be left at the site until removal is directed by the Inspector. Use of toilet facilities in the work under construction shall not be permitted.

ARTICLE 44. CLEANING UP

CONTRACTOR at all times shall keep work site free from debris such as waste, rubbish, and excess materials and equipment caused by this work. CONTRACTOR shall not leave debris under, in, or about the work site, but shall promptly remove same. Upon completion of work, CONTRACTOR shall clean interior and exterior of building, including fixtures, equipment, walls, floors, ceilings, roofs, window sills and ledges, horizontal projections, and any areas where debris has collected. CONTRACTOR shall clean and polish all glass, plumbing fixtures, and finish hardware and similar finish surfaces and equipment and remove temporary fencing, barricades, planking, sanitary facilities and similar temporary facilities from site. If CONTRACTOR fails to clean up, the DISTRICT shall do so and the cost thereof shall be charged to the CONTRACTOR and deducted from any progress payment due.

ARTICLE 45. PATENTS, ROYALTIES, AND INDEMNITIES

The CONTRACTOR shall hold and save the DISTRICT and its governing board, officers, agents, and employees harmless from liability of any nature or kind, including cost and expense, for or on account of any patented or unpatented invention, process, article, or appliance manufactured or used in the performance of this Agreement, including its use by the DISTRICT, unless otherwise specifically provided in the Project Documents, and unless such liability arises from the sole negligence, or active negligence, or willful misconduct of the DISTRICT.

ARTICLE 46. GUARANTEE

(a) CONTRACTOR warrants that the work (which includes any equipment furnished by CONTRACTOR as part of the materials) shall: (a) be free from defects in workmanship and material; (b) be free from defects in any design performed by CONTRACTOR; (c) be new, and conform and perform to the requirements stated in the specifications and where detail requirements are not so stated, shall conform to applicable industry standards; and (d) be suitable for the use stated in the specifications.

(b) The warranty period for discovery of defective work shall commence on the date stamped on the Notice of Completion verifying County recordation and continue for the period set forth in the specifications or for one year if not so specified. If, during the warranty period, the work is not available for use due to defective work, such time of unavailability shall not be counted as part

of the warranty period. The warranty period for corrected defective work shall continue for a duration equivalent to the original warranty period.

(c) District shall give CONTRACTOR prompt written notice after discovery of any defective work. CONTRACTOR shall correct any such defective work, as well as any damage to any other part of the work resulting from such defective work, and provide repair, replacement, or reimbursement, at its sole expense, in a manner approved by the DISTRICT and with due diligence and dispatch as required to make the work ready for use by DISTRICT, ordinary wear and tear, unusual abuse or neglect excepted. Such corrections shall include, but not be limited to, any necessary adjustments, modifications, changes of design (unless of DISTRICT's design), removal, repair, replacement or reinstallation, and shall include all necessary parts, materials, tools, equipment, transportation charges and labor as may be necessary, and cost of removal and replacement of work shall be performed at a time and in such a manner so as to minimize the disruption to DISTRICT's use of the work.

(d) In the event of failure of CONTRACTOR or Surety to commence and pursue with diligence said repairs or replacements within ten (10) calendar days after being notified in writing, DISTRICT is hereby authorized to proceed to have defects repaired or replaced and made good at expense of CONTRACTOR and Surety who hereby agree to pay costs and charges therefore immediately on demand.

(e) If, in the opinion of the DISTRICT, defective work creates a dangerous condition or requires immediate correction or attention to prevent further loss to the DISTRICT or to prevent interruption of operations of the DISTRICT, the DISTRICT will attempt to give the written notice required by this Article. If the CONTRACTOR or Surety cannot be contacted or neither complies with the DISTRICT's requirements for correction within a reasonable time as determined by the DISTRICT, the DISTRICT may, notwithstanding the provisions of this Article, proceed to make such correction or provide such attention and the costs of such correction or attention shall be charged against the CONTRACTOR and Surety. Such action by the DISTRICT will not relieve the CONTRACTOR and Surety of the guarantees provided in this Article or elsewhere in the Project Documents.

(f) This Article does not in any way limit the guarantees on any items for which a longer guarantee is specified or on any items for which a manufacturer gives a guarantee for a longer period. CONTRACTOR shall furnish to DISTRICT all appropriate guarantee or warranty certificates upon completion of the Project or upon request by DISTRICT.

(g) All guarantees required under this Article shall be in writing on the Guarantee form included in the Project Documents.

(h) CONTRACTOR shall provide to DISTRICT instruction manuals for all items which require same.

(i) Nothing herein shall limit any other rights or remedies available to DISTRICT.

(j) The DISTRICT may collect its reasonable costs and attorneys' fees in any action to enforce this Article.

ARTICLE 47. DUTY TO PROVIDE FIT WORKERS

(a) CONTRACTOR and subcontractors shall at all times enforce strict discipline and good order among their employees and shall not employ on work any unfit person or anyone not skilled

in work assigned to such person. It shall be the responsibility of CONTRACTOR to ensure compliance with this Article.

(b) Any person in the employ of the CONTRACTOR or subcontractors whom DISTRICT or ARCHITECT may deem incompetent, unfit, troublesome or otherwise undesirable shall be excluded from the work site and shall not again be employed on it except with written consent of DISTRICT.

ARTICLE 48. WAGE RATES, TRAVEL AND SUBSISTENCE

(a) Pursuant to the provisions of Article 2 (commencing at Section 1770), Chapter 1, Part 7, Division 2 of the Labor Code, the governing board of DISTRICT has obtained the general prevailing rate of per diem wages and the general prevailing rate for holiday and overtime work in the locality in which this public work is to be performed for each craft, classification or type of worker needed for this Project from the Director of the Department of Industrial Relations ("Director.") These rates are on file with the Clerk of the DISTRICT's governing board and copies will be made available to any interested party on request. CONTRACTOR shall post a copy of such wage rates at the work site. Labor Code Section 1773.2. The rates are available on the Internet at www.dir.ca.gov "Statistics & Research."

(b) Holiday and overtime work, when permitted by law, shall be paid for at a rate of at least one and one-half times the above-specified rate of per diem wages, unless otherwise specified. Holidays shall be defined in the Collective Bargaining Agreement applicable to each particular craft, classification or type of worker employed.

(a) CONTRACTOR shall pay and shall cause to be paid each worker engaged in work on the Project not less than the general prevailing rate of per diem wages determined by the Director, regardless of any contractual relationship, which may be alleged to exist between the CONTRACTOR or any subcontractor and such workers.

(d) CONTRACTOR shall pay and shall cause to be paid to each worker needed to execute the work on the Project travel and subsistence payments, as such travel and subsistence payments are defined in the applicable collective bargaining agreements filed with the Department of Industrial Relations in accordance with Labor Code Section 1773.8.

(e) If during the period this bid is required to remain open, the Director of Industrial Relations determines that there has been a change in any prevailing rate of per diem wages in the locality in which this public work is to be performed, such change shall not alter the wage rates in the Notice Calling for Bids or the contract subsequently awarded.

(f) Pursuant to Labor Code Section 1775, CONTRACTOR shall as a penalty to the DISTRICT, forfeit two hundred (\$200) maximum for each calendar day, or portion thereof, for each worker paid less than the prevailing rate of per diem wages, determined by the Director, for such craft or classification in which such worker is employed for any public work done under the Agreement by CONTRACTOR or by any subcontractor under it. The amount of the penalty shall be determined by the Labor Commission and shall be based on consideration of the CONTRACTOR's mistake, inadvertence or neglect in failing to pay the correct prevailing rate of per diem wage, or the previous record of the CONTRACTOR in meeting his or her prevailing rate of per diem wage obligations, or the CONTRACTOR's willful failure to pay the correct prevailing rate of per diem wages. A mistake, inadvertence or neglect in failing to pay the correct prevailing rate of per diem wage is not excusable if the CONTRACTOR had knowledge of his or her obligations under this

part. The difference between such prevailing rate of per diem wage and the amount paid to each worker for each calendar day or portion thereof for which each worker was paid less than the prevailing rate of per diem wage shall be paid to each worker by the CONTRACTOR.

(g) Any worker employed to perform work on the Project, which work is not covered by any craft or classification listed in the general prevailing rate of per diem wages determined by the Director shall be paid not less than the minimum rate of wages specified therein for the craft or classification which most nearly corresponds to work to be performed by them, and such minimum wage rate shall be retroactive to time of initial employment of such person in such craft or classification.

(h) Pursuant to Labor Code Section 1773.1, per diem wages are deemed to include employer payments for health and welfare, pension, vacation, travel time, and subsistence pay as provided for in Labor Code Section 1773.8.

(i) CONTRACTOR shall post at appropriate conspicuous points on the site of the Project, a schedule showing all determined minimum wage rates and all authorized deductions, if any, from unpaid wages actually earned.

ARTICLE 49. HOURS OF WORK

(a) As provided in Article 3, (commencing at Section 1810), Chapter 1, Part 7, Division 2 of the Labor Code, eight (8) hours of labor shall constitute a legal day's work. The time of service of any worker employed at any time by the CONTRACTOR or by any subcontractor on any subcontract under this Agreement upon the work or upon any part of the work contemplated by this Agreement shall be limited and restricted by the Agreement to eight (8) hours per day, and forty (40) hours during any one week, except as hereinafter provided. Notwithstanding the provisions hereinabove set forth, work performed by employees of CONTRACTOR in excess of eight (8) hours per day and forty (40) hours during any one week, shall be permitted upon this public work upon compensation for all hours worked in excess of eight (8) hours per day at not less than one and one-half times the basic rate of pay.

(b) The CONTRACTOR shall keep and shall cause each subcontractor to keep an accurate record showing the name of and actual hours worked each calendar day and each calendar week by each worker employed by CONTRACTOR in connection with the work or any part of the work contemplated by this Agreement. The record shall be kept open at all reasonable hours to the inspection of the DISTRICT and to the Division of Labor Standards Enforcement, Department of Industrial Relations.

(c) Pursuant to Labor Code Section 1813, the CONTRACTOR shall pay to the DISTRICT a penalty of Twenty-Five Dollars (\$25) for each worker employed in the execution of this Contract by the CONTRACTOR or by any subcontractor for each calendar day during which such worker is required or permitted to work more than eight (8) hours in any one calendar day and 40 hours in any one calendar week in violation of the provisions of Article 3 (commencing at Section 1810), Chapter 1, Part 7, Division 2 of the Labor Code.

(d) Any work necessary to be performed after regular working hours, or on Sundays or other holidays shall be performed without additional expense to DISTRICT.

ARTICLE 50. PAYROLL RECORDS

(a) Pursuant to the provisions of Labor Code Section 1776, the CONTRACTOR shall keep and shall cause each subcontractor performing any portion of the work under this Agreement to

keep an accurate payroll record, showing the name, address, social security number, work classification, straight time and overtime hours worked each day and week, and the actual per diem wages paid to each journeyman, apprentice, worker, or other employee employed by CONTRACTOR in connection with the work.

(b) The payroll records enumerated under subdivision (a) shall be certified and shall be available for inspection at all reasonable hours at the principal office of the CONTRACTOR on the following basis:

(1) A certified copy of an employee's payroll record shall be made available for inspection or furnished to the employee or his or her authorized representative on request.

(2) A certified copy of all payroll records enumerated in subdivision (a) shall be made available for inspection or furnished upon request to a representative of the DISTRICT, the Division of Labor Standards Enforcement, and the Division of Apprenticeship Standards of the Department of Industrial Relations.

(3) A certified copy of all payroll records enumerated in subdivision (a) shall be made available for inspection upon request by the public or copies thereof made; provided, however, that a request by the public shall be made through either the District, the Division of Apprenticeship Standards, or the Division of Labor Standards Enforcement. If the requested payroll records have not been provided pursuant to paragraph (2), the requesting party shall, prior to being provided the records, reimburse the costs of preparation by the CONTRACTOR, subcontractors, and the entity through which the request was made. The public shall not be given access to the records at the principal office of the CONTRACTOR.

(4) The form of certification shall be as follows:

I, _____ (Name-print), the undersigned, am _____ (position in business) with the authority to act for and on behalf of _____ (Name of business and/or CONTRACTOR), certify under penalty of perjury that the records or copies thereof submitted and consisting of _____ (description, number of pages) are the originals or true, full and correct copies of the originals which depict the payroll record(s) of the actual disbursements by way of cash, check, or whatever form to the individual or individuals named.

Dated: _____ Signature: _____

(c) Contractor shall file a certified copy of the payroll records enumerated in subdivision (a) with the entity that requested the records within ten (10) days after receipt of a written request. In the event that the CONTRACTOR fails to comply within the 10-day period, the CONTRACTOR shall, as a penalty to the DISTRICT, forfeit Twenty-Five Dollars (\$25) for each calendar day, or portion thereof, for each worker, until strict compliance is effectuated. Upon the request of the Division of Apprenticeship Standards or the Division of Labor Standards Enforcement, these penalties shall be withheld from progress payments then due. Labor Code Section 1776(g).

(d) Any copy of payroll records made available for inspection as copies and furnished upon request to the public by the DISTRICT, the Division of Apprenticeship Standards, or the Division of Labor Standards Enforcement shall be marked or obliterated in such a manner as to prevent

disclosure of an individual's name, address, and social security number. The name and address of the CONTRACTOR shall not be marked or obliterated.

(e) The CONTRACTOR shall inform the DISTRICT of the location of the payroll records enumerated under subdivision (a), including the street address, city and county, and shall, within five (5) working days, provide a written notice of a change of location and address.

(f) It shall be the responsibility of the CONTRACTOR to ensure compliance with the provisions of this Article 50 and the provisions of Labor Code Section 1776.

ARTICLE 51. APPRENTICES

(a) The CONTRACTOR acknowledges and agrees that, if this Agreement involves a dollar amount greater than or a number of working days greater than that specified in Labor Code Section 1777.5, this Agreement is governed by the provisions of Labor Code Section 1777.5. It shall be the responsibility of the CONTRACTOR to ensure compliance with this Article 51 and with Labor Code Section 1777.5 for all apprenticing occupations.

(b) Apprentices of any crafts or trades may be employed and, when required by Labor Code Section 1777.5, shall be employed provided they are properly registered in full compliance with the provisions of the Labor Code.

(c) Every such apprentice shall be paid the standard wage paid to apprentices under the regulations of the craft or trade at which he or she is employed, and shall be employed only at the work of the craft or trade to which he or she is registered.

(d) Only apprentices, as defined in Section 3077, who are in training under apprenticeship standards and written apprentice agreements under Chapter 4 (commencing at Section 3070), Division 3 of the Labor Code, are eligible to be employed on public works. The employment and training of each apprenticeship shall be in accordance with the provisions of the apprenticeship standards and apprentice agreements under which he or she is training.

(e) Pursuant to Labor Code Section 1777.5, the CONTRACTOR and any subcontractors employing workers in any apprenticeship craft or trade in performing any work under this Agreement shall employ apprentices in at least the ratio set forth in Section 1777.5 and apply to the applicable joint apprenticeship committee for a certificate approving the CONTRACTOR or subcontractor under the applicable apprenticeship standards for the employment and training of apprentices.

(f) Every contractor and subcontractor shall submit contract award information to the applicable joint apprenticeship committee, which shall include an estimate of journeyman hours to be performed under the Agreement, the number of apprentices to be employed and the approximate dates the apprentices will be employed.

(g) If the CONTRACTOR or subcontractor willfully fails to comply with Labor Code Section 1777.5, then, upon a determination of noncompliance by the Chief of the Division of Apprenticeship Standards, the CONTRACTOR or subcontractor shall be subject to the penalties imposed under Labor Code Section 1777.7. Interpretation and enforcement of these provisions shall be in accordance with the rules and procedures of the California Apprenticeship Council.

(h) The CONTRACTOR and all subcontractors shall comply with Labor Code Section 1777.6, which section forbids certain discriminatory practices in the employment of apprentices.

(i) CONTRACTOR shall become fully acquainted with the law regarding apprentices prior to commencement of the work. Special attention is directed to Sections 1777.5, 1777.6, and 1777.7 of the Labor Code, and Title 8, California Code of Regulations, Section 200, et seq. Questions may be directed to the State Division of Apprenticeship Standards, 455 Golden Gate Avenue, 8th Floor, San Francisco, California 94102, (415) 703-4920.

ARTICLE 52. LABOR - FIRST AID

The CONTRACTOR shall maintain emergency first aid treatment for CONTRACTOR's workers on the Project, which complies with the Federal Occupational Safety and Health Act of 1970 (29 U.S.C.A., Sec. 651, et seq.).

ARTICLE 53. PROTECTION OF PERSONS AND PROPERTY

(a) The CONTRACTOR shall be responsible for all damages to persons or property that occur as a result of its fault or negligence in connection with the prosecution of this Agreement and shall take all necessary measures and be responsible for the proper care and protection of all materials delivered and work performed until completion and final acceptance by the DISTRICT. CONTRACTOR shall provide such heat, covering, and enclosures as are necessary to protect all work, materials, equipment, appliances, and tools against damage by weather conditions. All work shall be solely at the CONTRACTOR's risk with the exception of damage to the work caused by "acts of God" as defined in Public Contract Code Section 7105.

(b) CONTRACTOR shall take, and require subcontractors to take, all necessary precautions for safety of workers and shall comply with all applicable federal, state, local and other safety laws, standards, orders, rules, regulations, and building codes to prevent accidents or injury to persons on, about, or adjacent to the work site and to provide a safe and healthful place of employment. CONTRACTOR shall furnish, erect and properly maintain at all times, as directed by DISTRICT or ARCHITECT or required by conditions and progress of work, all necessary safety devices, safeguards, construction canopies, signs audible devices for protection of the blind, safety rails, belts and nets, barriers, lights, and watchmen for protection of workers and the public and shall post danger signs warning against hazards created by such features in the course of construction. CONTRACTOR shall designate a responsible employee, whose duty shall be to post information regarding protection and obligations of workers and other notices required under occupational safety and health laws, to comply with reporting and other occupational safety requirements, and to protect the life, safety and health of workers. Name and position of person so designated shall be reported in writing to DISTRICT by CONTRACTOR. CONTRACTOR shall correct any violations of safety laws, standards, orders, rules, or regulations. Upon the issuance of a citation or notice of violation by the Division of Occupational Safety and Health, such violation shall be corrected immediately by the CONTRACTOR at CONTRACTOR's expense.

(c) In an emergency affecting safety of person or of work or of adjoining property, CONTRACTOR, without special instruction or authorization from ARCHITECT or DISTRICT, is hereby permitted to act, at its discretion, to prevent such threatened loss or injury; and CONTRACTOR shall so act if so authorized or instructed by Architect or DISTRICT. Any compensation claimed by CONTRACTOR on account of emergency work shall be determined by written agreement with the DISTRICT.

(d) CONTRACTOR shall take adequate precautions to protect existing roads, sidewalks, curbs, pavements, utilities, adjoining property and structures (including, without limitation, protection from settlement or loss of lateral support), and to avoid damage thereto, and repair any damage thereto caused by construction operations.

- (e) CONTRACTOR shall (unless waived by the DISTRICT in writing):
- (1) When performing new construction on existing sites, become informed and take into specific account the maturity of the students on the site; perform work which may interfere with school routine before or after school hours; enclose working area with a substantial barricade; not allow any unauthorized individuals on the site; require all workers on the Project to be conspicuously identified either by a firm logo on their clothing or prominent identification badge and arrange work to cause a minimum amount of inconvenience and danger to students and faculty in their regular school activities.
 - (2) Provide substantial barricades around any shrubs or trees indicated to be preserved.
 - (3) Deliver materials to building area over route designated by ARCHITECT.
 - (4) When directed by DISTRICT, take preventive measures to eliminate objectionable dust.
 - (5) Enforce all instructions of DISTRICT and ARCHITECT regarding signs, advertising, fires, and smoking and require that all workers comply with all regulations while on construction site.
 - (6) Take care to prevent disturbing or covering any survey markers, monuments, or other devices marking property boundaries or corners. If such markers are disturbed by accident, they shall be replaced by an approved civil engineer at no cost to the DISTRICT.

ARTICLE 54. NON-DISCRIMINATION

In the performance of the terms of this Agreement, CONTRACTOR agrees that it will not engage in nor permit such subcontractor as it may employ to engage in unlawful discrimination in employment of persons because of the race, religious creed, color, national origin, ancestry, physical handicap, medical condition, marital status, age or sex of such persons.

ARTICLE 55. SCHEDULE OF VALUES AND PERIODICAL ESTIMATES

- (a) CONTRACTOR shall furnish on form(s) approved by DISTRICT:
- (1) Within ten (10) calendar days of award of contract a detailed schedule of values giving complete breakdown of contract price for each component of the Project or site which shall include all subcontractor/supplier agreements showing dollar amounts of these agreements to justify the schedule of values; and
 - (2) A periodical itemized estimate of work done for purpose of making partial payments thereon. Change order work shall be clearly identified on a separate schedule of values.
 - (3) Within ten (10) calendar days of request of DISTRICT, a schedule of estimated monthly payments which shall be due CONTRACTOR under the Agreement.
- (b) Values employed in making up any of these schedules are subject to the ARCHITECT's written approval and will be used only for determining basis of partial payments and will not be considered as fixing a basis for additions to or deductions from contract price.

ARTICLE 56. CONTRACTOR CLAIMS

If the CONTRACTOR shall claim compensation for any damage sustained by reason of the acts of the DISTRICT or its agents, CONTRACTOR shall, within five (5) calendar days after sustaining of such damage, make to the ARCHITECT a written statement of the damage sustained. On or before the 15th day of the month succeeding that in which such damage shall have been sustained the CONTRACTOR shall file with the DISTRICT an itemized statement of the details and amount of such damage, and unless such statement shall be made as thus required, CONTRACTOR's claims for compensation shall be forfeited and invalidated and it shall not be entitled to consideration for payment on account of any such damage.

ARTICLE 57. DISPUTES - ARCHITECT'S DECISIONS

(a) The ARCHITECT shall, within a reasonable time, make decisions on all matters relating to the CONTRACTOR's execution and progress of the work. The decisions of the ARCHITECT shall not be binding, but shall be advisory only on the CONTRACTOR for the purpose of CONTRACTOR's obligation to proceed with the work.

(b) Except for tort claims, all claims by the CONTRACTOR for a time extension, payment of money or damages arising from work done by, or on behalf of, the CONTRACTOR pursuant to the Agreement and payment of which is not otherwise expressly provided for or the claimant is not otherwise entitled to, or as to the amount of payment which is disputed by the DISTRICT of Three Hundred Seventy Five Thousand Dollars (\$375,000) or less shall be subject to the settlement procedures set forth in Public Contract Code Section 20104, et seq. which provisions are incorporated herein by reference.

(c) In the event of a dispute between the parties as to performance of the work, the interpretation of this Agreement or payment or nonpayment for work performed or not performed, the parties shall attempt to resolve the dispute. Pending resolution of the dispute, CONTRACTOR agrees to continue the work diligently to completion. If the dispute is not resolved, CONTRACTOR agrees it will neither rescind the Agreement nor stop the progress of the work, but CONTRACTOR's sole remedy shall be to submit such controversy to determination by a court of the State of California, in Orange County, having competent jurisdiction of the dispute, after the Project has been completed, and not before.

ARTICLE 58. PAYMENTS

(a) Unless otherwise specified in writing, each month within thirty (30) days after receipt by the DISTRICT of the monthly progress schedule and an undisputed, properly submitted payment request from CONTRACTOR which has been certified for payment by the Architect, there shall be paid to CONTRACTOR a sum equal to ninety five percent (95%) of value of work performed and of materials delivered to the jobsite and inspected and approved by the inspector of record and subject to or under the control of the DISTRICT and unused up to the last day of the previous month, less aggregate previous payments. Public Contract Code Section 20104.50 Monthly payments shall be made only on the basis of monthly estimates, which shall be prepared by CONTRACTOR on a form approved by DISTRICT and filed before the fifth day of the month during which payment is to be made. Work completed as estimated shall be an estimate only and no inaccuracy or error in said estimate shall operate to release CONTRACTOR or Surety from any damages arising from such work or from enforcing each and every provision of this Agreement, and DISTRICT shall have the right subsequently to correct any error made in any estimate for payment. CONTRACTOR SHALL NOT BE ENTITLED TO HAVE ANY PAYMENT ESTIMATES PROCESSED OR BE ENTITLED TO HAVE ANY PAYMENT FOR WORK PERFORMED SO LONG

AS ANY LAWFUL OR PROPER DIRECTION CONCERNING WORK, OR ANY PORTION THEREOF, GIVEN BY THE DISTRICT OR ARCHITECT SHALL REMAIN UNCOMPLIED WITH BY THE CONTRACTOR. CONTRACTOR AGREES TO THE FIVE PERCENT (5%) RETENTION ON ALL PROGRESS PAYMENTS. Public Contract Code Section 9203.

(b) DISTRICT has discretion to require from the CONTRACTOR any of the following information with the application for payment: (i) certified payroll covering the period of the prior application for payment; (ii) unconditional waivers and releases from all subcontractors/suppliers for which payment was requested under the prior application for payment; and/or (iii) receipts or bills of sale for any items. CONTRACTOR agrees that payment may be contingent upon District receiving any one or more of these documents.

(c) Before payment is made hereunder, a certificate in writing shall be obtained from the ARCHITECT stating that the work for which the payment is demanded has been performed in accordance with the terms of the Project Documents and that the amount stated in the certificate is due under the terms of the Project Documents, which certificate shall be attached to and made a part of the claim made and filed with the DISTRICT, provided that if the ARCHITECT shall, within three (3) days after written demand therefore, fail to deliver such certificate to the DISTRICT, the CONTRACTOR may file its claim with the DISTRICT without said certificate, but together with such claim shall be filed a statement that demand was made for such certificate and that the same was refused. Thereupon, the DISTRICT will either allow said claim as presented or shall, by an order entered on the minutes of said DISTRICT state the reasons for refusing to allow said claim. It is understood, moreover, that the certificate of the ARCHITECT shall not be conclusive upon the DISTRICT, but advisory only.

(d) Upon receipt of CONTRACTOR's payment request, DISTRICT shall review the payment request as soon as practicable after receipt for determining that the payment request is proper. Any payment request determined not to be proper shall be returned to the CONTRACTOR as soon as practicable but not later than seven (7) days after receipt and shall be accompanied by a document setting forth in writing the reasons(s) why the payment request was not proper. Public Contract Code Section 20104.50

(e) NO PAYMENT BY DISTRICT HEREUNDER SHALL BE INTERPRETED SO AS TO IMPLY THAT DISTRICT HAS INSPECTED, APPROVED, OR ACCEPTED ANY PART OF THE WORK.

(f) Unless otherwise provided, on or before making request for final payment of the undisputed amount due under the Agreement, CONTRACTOR shall submit to DISTRICT, in writing a summary of all claims for compensation under or arising out of this Agreement which were timely filed. The acceptance by CONTRACTOR of the payment of the final amount shall constitute a waiver of all claims against DISTRICT under or arising out of this Agreement, except those previously made, in a timely manner and in writing, and identified by CONTRACTOR as unsettled at the time of CONTRACTOR's final request for payment.

(g) CONTRACTOR shall pay each of its subcontractors from whom retention has been withheld each subcontractor's share of the retention received within seven (7) days from the time that all or any portion of the retention are received by the CONTRACTOR subject to any limitations set forth in Public Contract Code Section 7107(e).

(h) The final payment of the five percent (5%) retention of the value of the work done under this Agreement, if unencumbered, shall be made thirty-five (35) days after recording by the DISTRICT of the Notice of Completion at the County Recorder's Office. APPROVAL OF

COMPLETION OF THE PROJECT WILL BE MADE ONLY BY ACTION OF THE GOVERNING BOARD OF DISTRICT. Public Contract Code Section 7107.

ARTICLE 59. CHANGES AND EXTRA WORK

(a) DISTRICT may, as provided by law and without affecting the validity of this Agreement, order changes, modifications, deletions and extra work by issuance of written change orders from time to time during the progress of the Project, contract sum being adjusted accordingly. All such work shall be executed under conditions of the original Agreement except that any extension of time caused thereby shall be adjusted at time of ordering such change. DISTRICT has discretion to order changes on a "time and material" basis with adjustments to time made after CONTRACTOR has justified through documentation the impact on the critical path of the Project.

(b) Notwithstanding any other provision in the Project Documents, the adjustment in the contract sum, if any, and the adjustment in the contract time, if any, set out in a change order shall constitute the entire compensation and/or adjustment in the contract time due CONTRACTOR arising out of the change in the work covered by the change order unless otherwise provided in the change order. The amount of the compensation due CONTRACTOR shall be calculated pursuant to subparagraph (e) of this Article 59. The entire compensation shall not include any additional charges not set forth in subparagraph (e) and shall not include delay damages (due to processing of a change order, refusal to sign a change order) indirect, consequential, and incidental costs including any project management costs, extended home office and field office overhead, administrative costs and profit other than those amounts authorized under subparagraph (e) of this Article 59.

(c) In giving instructions, ARCHITECT shall have authority to make minor changes in work, not involving change in cost, and not inconsistent with purposes of the Project. The DISTRICT's Assistant Superintendent of Business Services may authorize changes in work involving a change in cost that does not exceed Fifteen Thousand Dollars (\$15,000). Otherwise, except in an emergency endangering life or property, no extra work or change shall be made unless in pursuance of a written order from DISTRICT, authorized by action of the governing board, and no claim for addition to contract sum shall be valid unless so ordered.

(d) If the ARCHITECT determines that work required to be done constitutes extra work outside the scope of the Agreement, the ARCHITECT shall send a request for a detailed proposal to the CONTRACTOR. CONTRACTOR will respond with a detailed proposal within five (5) calendar days of receipt of the Request for Proposal which shall include a complete itemized cost breakdown of all labor and materials showing actual quantities, hours, unit prices, and the wage rates required for the change. If the change order involves a change in construction time, a request for the time change shall accompany the change order cost breakdown. All such requests for time shall be specified by CONTRACTOR as either "work days" or "calendar days." Any request for time received with only the designation of "days" shall be considered calendar days. The term "work days" as used in this paragraph shall mean Monday through Friday, excluding Saturdays, Sundays and federal/State of California observed holidays. If the work is to be performed by a subcontractor, CONTRACTOR must include a bid from the subcontractor containing the same detailed information as required for CONTRACTOR. No extensions of time will be granted for change orders that, in the opinion of the ARCHITECT, do not affect the critical path of the Project.

(e) Value of any such extra work, change, or deduction shall be determined at the discretion of DISTRICT in one or more of the following ways:

(1) By mutual written acceptance of a lump sum proposal from CONTRACTOR properly itemized and supported by sufficient substantiating data to permit evaluation by DISTRICT and ARCHITECT.

(2) By unit prices contained in CONTRACTOR's original bid and incorporated in the Project Documents or fixed by subsequent agreement between DISTRICT and CONTRACTOR.

(3) By cost of material and labor and percentage for overhead and profit ("time and material"). If the value is determined by this method the following requirements shall apply:

(A) Daily Reports by Contractor.

(i) General. At the close of each working day, the CONTRACTOR shall submit a daily report to the ARCHITECT and the Inspector, on forms approved by the DISTRICT, together with applicable delivery tickets, listing all labor, materials, and equipment involved for that day, and for other services and expenditures when authorized concerning extra work items. An attempt shall be made to reconcile the report daily, and it shall be signed by the ARCHITECT and the CONTRACTOR. In the event of disagreement, pertinent notes shall be entered by each party to explain points, which cannot be resolved immediately. Each party shall retain a signed copy of the report. Reports by Subcontractors or others shall be submitted through the CONTRACTOR.

(ii) Labor. The report shall show names of workers, classifications, and hours worked and hourly rate. Project Superintendent expenses are not allowed.

(iii) Materials. The report shall describe and list quantities of materials used and unit cost.

(iv) Equipment. The report shall show type of equipment, size, identification number, and hours of operation, including loading and transportation, if applicable, and hourly/daily cost.

(v) Other Services and Expenditures. Other services and expenditures shall be described in such detail as the DISTRICT may require.

(B) Basis for Establishing Costs

(i) Labor. The costs of labor will be the actual cost for wages prevailing locally for each craft classification or type of workers at the time the extra work is done, plus employer payments of payroll taxes and insurance, health and welfare, pension, vacation, apprenticeship funds, and other direct costs resulting from federal, state or local laws, as well as assessments or benefits required by lawful collective bargaining agreements. The use of labor classification which would increase the extra work cost will not be permitted unless the CONTRACTOR establishes the necessity for such additional costs. Labor costs for equipment operators and helpers shall be reported only when such costs are not included in the invoice for equipment rental.

(ii) Materials. The cost of materials reported shall be at invoice or lowest current price at which such materials are locally available and delivered to the

work site in the quantities involved, plus sales tax, freight and delivery. The DISTRICT reserves the right to approve materials and sources of supply, or to supply materials to the CONTRACTOR if necessary for the progress of the work. No markup shall be applied to any material provided by the DISTRICT.

(iii) Tool and Equipment Rental. No payment will be made for the use of tools which have a replacement value of \$100 or less or where an invoice is not provided.

Regardless of ownership, the rates to be used in determining equipment rental costs shall not exceed listed rates prevailing locally at equipment rental source, or distributors, at the time the work is performed. The rental rates paid shall include the cost of fuel, oil, lubrication, supplies, small tools, necessary attachments, repairs and maintenance of any kind, depreciation, storage, insurance, and all incidentals. Necessary loading and transportation costs for equipment used on the extra work shall be included.

If equipment is used intermittently and, when not in use, could be returned to its rental source at less expense to the DISTRICT than holding it at the work site, it shall be returned, unless the CONTRACTOR elects to keep it at the work site at no expense to the DISTRICT.

All equipment shall be acceptable to the ARCHITECT, in good working condition, and suitable for the purpose for which it is to be used. Manufacturer's ratings and manufacturer's approved modifications shall be used to classify equipment and it shall be powered by a unit of at least the minimum rating recommended by the manufacturer.

(iv) Other Items. The DISTRICT may authorize other items which may be required on the extra work. Such items include labor, services, material and equipment which are different in their nature from those required by the work and which are of a type not ordinarily available from the CONTRACTOR or any of the subcontractors. Invoices covering all such items in detail shall be submitted with the request for payment.

(v) Invoices. Vendors' invoices for material, equipment rental, and other expenditures, shall be submitted with the request for payment. If the request for payment is not substantiated by invoices or other documentation, the DISTRICT may establish the cost of the item involved at the lowest price which was current at the time of the report.

(C) The following form shall be used as applicable by the DISTRICT and CONTRACTOR to communicate proposed additions and deductions to the Agreement.

	<u>EXTRA</u>	<u>CREDIT</u>
i. Material/Equipment (attach itemized quantity and unit cost plus sales tax)	_____	_____
ii. Labor (attach itemized hours and rates)	_____	_____
iii. Subtotal	_____	_____
iv. If subcontractor performed work, add Subcontractor's overhead and profit to portions performed by it, not to exceed 15% of Item iii. above	_____	_____
v. Subtotal	_____	_____
vi. Contractor's Overhead and Profit, not to exceed 15% of Item v if Contractor performed the work. If subcontractor performed the work, not to exceed 5% of Item v. Of portions performed by Contractor and subcontractors, portions performed by Contractor shall not exceed 15% of Item V, and portions performed by Subcontractor shall not exceed 5% of Item v.	_____	_____
vii. Subtotal	_____	_____
viii. Bond and Liability Insurance Premium, if in fact additional bonds or insurance were actually purchased, not to exceed 1% of Item vii.	_____	_____
ix. Total	_____	_____

(4) IT IS EXPRESSLY UNDERSTOOD THAT THE VALUE OF SUCH EXTRA WORK OR CHANGES, AS DETERMINED BY ANY OF THE AFOREMENTIONED METHODS, EXPRESSLY INCLUDES ANY AND ALL OF CONTRACTOR'S COSTS AND EXPENSES, BOTH DIRECT AND INDIRECT, RESULTING FROM ADDITIONAL TIME REQUIRED ON THE PROJECT, OR RESULTING FROM DELAYS TO THE PROJECT. ANY COSTS OR EXPENSES NOT INCLUDED ARE DEEMED WAIVED. FOR PURPOSES OF DETERMINING THE COST, IF ANY, OF ANY EXTRA WORK, CHANGE, ADDITION OR OMISSION HEREUNDER, ALL TRADE DISCOUNTS, REBATES, REFUNDS, AND ALL RETURNS FROM THE SALE OF SURPLUS MATERIALS AND EQUIPMENT SHALL ACCRUE AND BE CREDITED TO CONTRACTOR, AND CONTRACTOR SHALL ENSURE THAT SUCH DISCOUNTS, REBATES, REFUNDS, AND RETURNS MAY BE SECURED, AND THE AMOUNT THEREOF SHALL BE ALLOWED AS A REDUCTION OF CONTRACTOR'S COST IN DETERMINING THE ACTUAL COST OF CONSTRUCTION FOR PURPOSES OF ANY EXTRA WORK, CHANGE, ADDITION OR OMISSIONS IN THE WORK AS PROVIDED HEREIN.

(f) If the CONTRACTOR should claim that any instruction, request, drawing, specification, action, condition, omission, default, or other situation obligates the DISTRICT to pay additional compensation to CONTRACTOR or to grant an extension of time, or constitutes a waiver of any provision in the Agreement, CONTRACTOR shall notify the DISTRICT, in writing, of such claim within five (5) calendar days from the date CONTRACTOR has actual or constructive notice of the factual basis supporting the claim. The notice shall state the factual bases for the claim and cite in detail the Project Documents (including plans and specifications) upon which the claim is based. The CONTRACTOR's failure to notify the DISTRICT within such five (5) day period shall be deemed a waiver and relinquishment of such a claim. If such notice be given within the specified time, the procedure for its consideration shall be as stated above in these General Conditions.

(g) "PROHIBITED USAGE OF CONTRACTOR QUALIFYING LANGUAGE STAMPS ON DISTRICT DRAWINGS OR CONTRACT FORMS." Contractor shall not countersign or endorse any form, drawing, change order, contract or other documents with any conditions not mutually agreed to in advance by the DISTRICT and the CONTRACTOR. Endorsement of a contract, change order, specification, drawing or form with the following: "This change order is being executed without waiver of the right to seek additional compensation for such services," shall be of no legal force or effect.

ARTICLE 60. COMPLETION

(a) The DISTRICT shall accept completion of the Project and have the Notice of Completion recorded within ten (10) days of acceptance of completion of the Project when the entire work including punch list items shall have been completed to the satisfaction of the DISTRICT. Civil Code Section 3093. The work may only be accepted as complete by action of the DISTRICT's Governing Board.

(b) However, the DISTRICT, at its sole option, may accept completion of the Project and have the Notice of Completion recorded when the entire work including individual portions of the work shall have been completed to the satisfaction of the DISTRICT, except for minor corrective items, as distinguished from incomplete items.

(c) A final walk through of the Project to determine completion and to record the Notice of Completion shall occur only upon a valid claim by CONTRACTOR that the Project is complete except for minor corrective items. Any erroneous claims of completion by CONTRACTOR

resulting in a premature walk through shall be at CONTRACTOR's sole cost and expense and DISTRICT shall make adjustments to the contract price by reducing the amount thereof to pay for any costs incurred by the DISTRICT due to the erroneous claims by the CONTRACTOR that the Project is complete. Minor corrective items shall be identified in the final walk through of the Project.

(d) If the CONTRACTOR fails to complete the minor corrective items prior to the expiration of the thirty-five (35) day period immediately following recording of the Notice of Completion, the DISTRICT shall withhold from the final payment an amount equal to one hundred fifty percent (150%), as determined by the DISTRICT, of the amount of each item until such time as the item is completed. Public Contract Code Section 7107. At the end of such 35-day period, if there are items remaining to be corrected, the DISTRICT may elect to proceed as provided in Article 61(b) entitled "Adjustments to Contract Price."

ARTICLE 61. ADJUSTMENTS TO CONTRACT PRICE

(a) If CONTRACTOR defaults or neglects to carry out the work in accordance with the Project Documents or fails to perform any provision thereof, DISTRICT may, after ten (10) days written notice to the CONTRACTOR and without prejudice to any other remedy it may have, make good such deficiencies.

(b) The DISTRICT shall adjust the total contract price by reducing the amount thereof by the cost of making good such deficiencies. If DISTRICT deems it inexpedient to correct work not done in accordance with the Project Documents, an equitable reduction in the contract price shall be made therefore.

ARTICLE 62. CORRECTION OF WORK

(a) CONTRACTOR shall promptly remove all work identified by DISTRICT as failing to conform to the Project Documents, whether incorporated or not. CONTRACTOR shall promptly replace and re-execute its own work to comply with Project Documents without additional expense to DISTRICT and shall bear the expense of making good all work of other contractors destroyed or damaged by such removal or replacement.

(b) If CONTRACTOR does not remove such work within a reasonable time, fixed by written notice, DISTRICT may remove it and may store the material at CONTRACTOR's expense. If CONTRACTOR does not pay expenses of such removal within ten (10) days' time thereafter, DISTRICT may, upon ten (10) days written notice, sell such materials at auction or at private sale and shall account for net proceeds thereof, after deducting all costs and expenses that should have been borne by CONTRACTOR.

ARTICLE 63. EXTENSION OF TIME - LIQUIDATED DAMAGES

(a) The CONTRACTOR and DISTRICT hereby agree that the exact amount of damages for failure to complete the work within the time specified is extremely difficult or impossible to determine. CONTRACTOR shall be assessed liquidated damages for each and every day the work required under the Project Documents remains unfinished past the time for completion, as set forth in the Agreement, and any extensions of time granted by the DISTRICT to the CONTRACTOR under the terms of the Project Documents. The CONTRACTOR will pay to the DISTRICT or DISTRICT may retain from amounts otherwise payable to the CONTRACTOR, said amount for each day after failure to meet the requirements of the contract completion as scheduled in the Agreement. Government Code Section 53069.85. For purposes of this article,

the work shall be considered "complete" in accordance with the provisions of Article 60, "COMPLETION", except that the work may be considered complete without formal acceptance by the DISTRICT Governing Board so long as the Governing Board, at its next regularly scheduled meeting, accepts the work.

(b) CONTRACTOR shall not be charged for liquidated damages, as set forth above, because of any delays in completion of work which are not the fault or negligence of CONTRACTOR, including but not restricted to, acts of God as defined in Public Contract Code section 7105, acts of enemy, epidemics, pandemics, and quarantine restrictions. Any delays caused by acts of God, as defined in Public Contract Code section 7105, acts of enemy, epidemics, pandemics, and quarantine restrictions (collectively, "Force Majeure Events") shall be deemed non-compensable excusable delays. CONTRACTOR shall within ten (10) days of beginning of any such delay, notify DISTRICT in writing of causes of delay. CONTRACTOR shall provide documentation and justification to substantiate the delay and its relation to the Project's critical path. DISTRICT shall ascertain the facts and extent of delay and grant extension of time for completing work when, in its judgment, the findings of fact justify such an extension. The DISTRICT's finding of fact thereon shall be final and conclusive on the parties hereto. Extension of time shall apply only to that portion of work affected by the delay, and shall not apply to other portions of work not so affected. An extension of time may only be granted after proper compliance with Article 32 requiring preparation and submission of a properly prepared CPM schedule.

(c) Excusable Delay Is Not Compensable. No extended overhead, general conditions costs, impact costs, out-of-sequence costs or any other type of compensation, by any name or characterization, shall be paid to the Contractor for any delay to any activity not designated as a critical path item on the latest approved Project schedule or if caused by Force Majeure Events.

ARTICLE 64. PAYMENTS WITHHELD

(a) In addition to amount which DISTRICT may retain under Article entitled "COMPLETION" and Article entitled "PAYMENTS," DISTRICT may withhold a sufficient amount or amounts of any payment or payments otherwise due to CONTRACTOR, as in its judgment may be necessary to cover:

- (1) Payments which may be past due and payable for just claims against CONTRACTOR or any subcontractors, or against and about the performance of work on the Project, including, without limitation, payments made pursuant to the Article entitled "PAYMENTS BY CONTRACTOR."
- (2) The cost of defective work which CONTRACTOR has not remedied.
- (3) Liquidated damages assessed against CONTRACTOR.
- (4) Penalties for violation of labor laws.
- (5) The cost of materials ordered by the DISTRICT pursuant to Article 33 entitled "MATERIALS AND WORK."
- (6) The cost of completion of this Agreement if there exists a reasonable doubt that this Agreement can be completed for the balance then unpaid to CONTRACTOR.
- (7) Damage to DISTRICT, another contractor, or subcontractor.

- (8) Site clean-up as provided in Article 44 entitled "CLEANING UP."
- (9) Payments to indemnify, defend, or hold harmless the DISTRICT.
- (10) Any payments due to the District including but not limited to payments for failed tests, utilities or imperfections.
- (11) Extra services for ARCHITECT.
- (12) Extra services for the INSPECTOR including but not limited to reinspection required due to CONTRACTOR's failed tests or installation of unapproved or defective materials and CONTRACTOR's requests for inspection and CONTRACTOR's failure to attend the inspection.
- (13) Failure of CONTRACTOR to submit on a timely basis, proper and sufficient documentation required by the Project Documents, including without limitation, monthly progress schedules, shop drawings, submittal schedules, schedule of values, product data and samples, proposed product lists, executed change orders and verified reports.
- (14) Any other obligation(s) of the DISTRICT which the DISTRICT is authorized and/or compelled by law to perform.

(b) If the above grounds are in the opinion of the DISTRICT removed by or at the expense of CONTRACTOR, payment shall be made for amounts withheld because of them.

(c) DISTRICT may apply such withheld amount or amounts to payment of such claims or obligations at its discretion. In so doing, DISTRICT shall make such payments on behalf of CONTRACTOR. If any payment is so made by DISTRICT, then such amount shall be considered as a payment made under contract by DISTRICT to CONTRACTOR and DISTRICT shall not be liable to CONTRACTOR for such payments made in good faith. Such payments may be made without prior judicial determination of claim or obligations. DISTRICT will render CONTRACTOR an accounting of such funds disbursed on behalf of CONTRACTOR.

(d) As an alternative to payment of such claims or obligations, DISTRICT, in its sole discretion, may reduce the total contract price as provided in Article 61 entitled "ADJUSTMENTS TO CONTRACT PRICE."

ARTICLE 65. TAXES

(a) CONTRACTOR will pay all applicable federal, state and local taxes on all materials, labor, or services furnished by it, and all taxes arising out of its operations under the Project Documents.

(b) If under federal excise tax law any transaction hereunder constitutes a sale on which a federal excise tax is imposed and the sale is exempt from such excise tax because it is a sale to a state or local government for its exclusive use, the DISTRICT, upon request, will execute documents necessary to show (1) that the DISTRICT is a political subdivision of the State for the purposes of such exemption and (2) that the sale is for the exclusive use of the DISTRICT. No excise tax for such materials shall be included in any bid price.

ARTICLE 66. NO ASSIGNMENT

The CONTRACTOR shall not assign, transfer, convey, sublet or otherwise dispose of this Agreement or of its rights, title or interest in or to the same or any part thereof. If the CONTRACTOR shall assign, transfer, convey, sublet or otherwise dispose of the Agreement or its right, title or interest therein, or any part thereof, such attempted or purported assignment, transfer, conveyance, sublease or other disposition shall be null, void and of no legal effect whatsoever; and the Agreement may, at the option of the DISTRICT, be terminated, revoked and annulled, and the DISTRICT shall thereupon be relieved and discharged from any and all liability and obligations growing out of the same to the CONTRACTOR, and to its purported assignee or transferee.

ARTICLE 67. NOTICE

Any notice from one party to the other or otherwise under the Agreement shall be in writing and shall be dated and signed by party giving such notice or by a duly authorized representative of such party. Any such notice shall not be effective for any purpose whatsoever unless served in one of the following manners:

- (1) If notice is given to DISTRICT, by personal delivery thereof to DISTRICT, or by depositing same in United States mail, enclosed in a sealed envelope addressed to DISTRICT, and sent by registered or certified mail with postage prepaid;
- (2) If notice is given to CONTRACTOR, by personal delivery thereof to said CONTRACTOR, or to CONTRACTOR's superintendent at site of Project, or by depositing same in United States mail, enclosed in a sealed envelope addressed to said CONTRACTOR at its regular place of business or at such address as may have been established for the conduct of work under this Agreement, and sent by registered or certified mail with postage prepaid;
- (3) If notice is given to surety or other persons, by personal delivery to such surety or other person, or by depositing same in United States mail, enclosed in a sealed envelope, addressed to such surety or person at the address of such surety or person last communicated by surety or other person to party giving notice, and sent by registered or certified mail with postage prepaid.

ARTICLE 68. NO WAIVER

The failure of the DISTRICT in any one or more instances to insist upon strict performance of any of the terms of this Agreement or to exercise any option herein conferred shall not be construed as a waiver or relinquishment to any extent of the right to assert or rely upon any such terms or option on any future occasion.

ARTICLE 69. NON-UTILIZATION OF ASBESTOS MATERIAL

- (a) The CONTRACTOR will be required to execute and submit the Certificate Regarding Non-Asbestos Containing Materials.
- (b) Should asbestos containing materials be installed by the CONTRACTOR in violation of this certification, or if removal of asbestos containing materials is part of the Project, decontaminations and removals will meet the following criteria:

- (1) Decontamination and removal of work found to contain asbestos or work installed with asbestos containing equipment shall be done only under the supervision of a qualified consultant, knowledgeable in the field of asbestos abatement and accredited by the Environmental Protection Agency (EPA).
 - (2) The asbestos removal contractor shall be an EPA accredited contractor qualified in the removal of asbestos and shall be chosen and approved by the asbestos consultant who shall have sole discretion and final determination in this matter.
 - (3) The asbestos consultant shall be chosen and approved by the DISTRICT who shall have sole discretion and final determination in this matter.
 - (4) The work will not be accepted until asbestos contamination is reduced to levels deemed acceptable by the asbestos consultant.
- (c) Cost of all asbestos removal, including, but not necessarily limited to the cost of the asbestos removal contractor, the cost of the asbestos consultant, analytical and laboratory fees, time delays and additional costs as may be incurred by the DISTRICT shall be borne entirely by the CONTRACTOR.
- (d) Hold Harmless: Interface of work for the Project with work containing asbestos shall be executed by the CONTRACTOR at his/her risk and at his/her discretion with full knowledge of the currently accepted standards, hazards, risks and liabilities associated with asbestos work and asbestos containing products. By execution of the Agreement, the CONTRACTOR acknowledges the above and agrees to hold harmless the DISTRICT, its Governing Board, employees, agents, and ARCHITECT and assigns for all asbestos liability, which may be associated with this work. The CONTRACTOR further agrees to instruct his/her employees with respect to the above mentioned standards, hazards, risks and liabilities.

ARTICLE 70. LEAD

Pursuant to the Lead-Safe Schools Protection Act (Education Code Sections 32240, et seq.) and other applicable law, the CONTRACTOR shall not use lead-based paint, lead plumbing and solders, or other potential sources of lead contamination in the construction of any new school facility or the modernization or renovation of any existing school facility.

ARTICLE 71. CRIMINAL RECORDS CHECK

Education Code Section 45125.1 provides that if the employees of any entity that has a contract with a school district may have any contact with pupils, those employees shall submit or have submitted their fingerprints in a manner authorized by the Department of Justice together with a fee determined by the Department of Justice to be sufficient to reimburse the Department for its costs incurred in processing the application. The CONTRACTOR shall not permit an employee to come in contact with DISTRICT pupils until the Department of Justice has ascertained that the employee has not been convicted of a violent or serious felony. The CONTRACTOR shall certify in writing to the Governing Board of the DISTRICT that none of its employees who may come in contact with pupils have been convicted of a violent or serious felony. Criminal Records Check Certification by CONTRACTOR is included in the Project Documents.

ARTICLE 72. DISABLED VETERAN BUSINESS ENTERPRISES

Each bidder must meet goals and requirements relating to three percent (3%) participation by Disabled Veteran Business Enterprises, established by the DISTRICT and the State Allocation Board (SAB), or make a good faith effort with respect thereto, in accordance with the DISTRICT's policies and procedures. CONTRACTOR may obtain information from the Office of Small Business Certification and Resources (OSBCR) at <http://www.dgs.ca.gov/osbcr> or (916) 323-5478. The CONTRACTOR shall be required to submit to the DISTRICT the DVBE Certification which is included in the Project Documents. Prior to, and as a condition precedent for final payment on the Project, the CONTRACTOR shall provide appropriate documentation to the DISTRICT so that the DISTRICT can assess its success at meeting the DVBE participation goal.

ARTICLE 73. TOBACCO FREE POLICY

CONTRACTOR has been advised and is aware that DISTRICT has adopted a Board Policy which prohibits the use of tobacco products, including smokeless tobacco, anywhere on DISTRICT property. CONTRACTOR shall be responsible for the enforcement of DISTRICT's tobacco-free policy among all CONTRACTOR's employees and subcontractors while on DISTRICT property. CONTRACTOR understands and agrees that should any employee or subcontractor of CONTRACTOR violate the DISTRICT's Board Policy after having already been warned once for violating DISTRICT's tobacco-free policy, CONTRACTOR shall remove the individual for the duration of the Project. CONTRACTOR shall not be entitled to any additional compensation and/or time in completing the Project for such removal.

ARTICLE 74. GOVERNING LAW

The laws of the State of California shall govern the Project and the Agreement.

ARTICLE 75. - NOT USED -

- END OF GENERAL CONDITIONS -

**SPECIAL CONDITIONS
(ATTACHED HERETO)**

**LEASE OF RELOCATABLE BUILDINGS
BID NO. 2026/27-1FA**

SPECIAL CONDITIONS

1. The District requires the lease of relocatable buildings to be installed at school sites within Irvine Unified School District. The District has not determined the amount or type of units that will be needed under this bid; however, the District reserves the right to order any combination of items in the bid in any number as needed from the successful bidder.

2. WORK PHASES: Phase I of the work shall commence on or before the date stated in the District's Notice to Proceed and shall be completed within twenty-five (25) calendar days from and after the date stated in the Notice to Proceed. Said Notice to Proceed shall not be issued prior to six (6) calendar days after award of the Contract, and shall not require that the work be commenced less than ten (10) calendar days from the date of issuance of the Notice to Proceed. Subsequent Purchase Orders shall act as the Notice to Proceed with the same requirement of said Notice.

PHASE I shall consist of the time allocated for preparation of drawings and specifications and any necessary corrections to those drawings and/or specifications identified by the District and/or Architect or the Division of State Architect (DSA) for the relocatable buildings.

For those buildings identified by the model number, the time for preparation of the drawings and specifications shall be twenty-one (21) calendar days. For those buildings identified by the model number plus the "Additive Alternates", the time for preparation of the drawings and specification shall be twenty-one (21) calendar days plus those additional calendar days for the "Additive Alternates", as agreed to and so stipulated in the Notice to Proceed or Purchase Order.

Corrections to the drawings and specifications as identified by the District and/or Architect or by the DSA shall be as follows:

- A. The time allocated for the District and the Architect checking, shall be seven (7) calendar days.
- B. The time allocated for the contractor to complete the District and/or Architect corrections and resubmit to the District and/or Architect shall be seven (7) calendar days from the receipt of such corrections.
- C. The review time by the DSA shall not be included in either Phase I or Phase II.
- D. The time allocated for the completion of all the DSA corrections by the successful bidder shall be seven (7) calendar days from the receipt of such corrections.
- E. Any DSA fee required for plan approval shall be the responsibility of the District.

In the event that the successful bidder requires more time to complete the work of Phase I than allocated, all additional time shall be a part of the Phase II work unless such additional time can be justified. Phase II work shall consist of the execution of the Agreement and the actual construction,

installation and completion of the relocatable building(s) all as indicated on the approved drawings and specifications.

Upon receipt of notification from the District, the successful bidder shall have sixty (60) calendar days to complete the Phase II work for a building identified by the model number and installed on wood foundations and one hundred twenty (120) calendar days for a building identified by the model number and installed on concrete foundations. Multiple installations will require additional calendar days for completion. Additional time for completion shall be negotiated and agreed to and so stipulated in the District Purchase Order or Notice to Proceed.

3. **LIQUIDATED DAMAGES:** The liquidated damages is one thousand dollars (\$1,000.00) per calendar day for each day the building(s) are delayed beyond the number of Phase II completion days specified in the Work Phases.

4. The work shall include all labor, material, equipment, appliances, supervision and transportation necessary to furnish, deliver and install the buildings.

5. The District shall be responsible for the preparation of the site(s). Each building area shall have a building pad area prepared to the following specifications:

- A. Twelve (12) inch building pad(s) shall be constructed level. The maximum allowable slope of the pad shall be six (6) inches across the diagonal from front to rear. The slope across the front, side to side, shall be level to six (6) inches.
- B. Building pad(s) shall be constructed to a point one (1) foot outside the building footprint in all directions.
- C. The soil bearing value of the pad(s) shall be a minimum 1,000 PSF.
- D. The site area adjacent to the building(s) shall have proper drainage away from the building.
- E. All vegetation shall be removed from the building pad area.
- F. For concrete foundation unless otherwise noted, the District shall be responsible for underground hazards, site demolition, import/export of soils, pad excavation, surveying, site improvements with the exception of concrete foundation, backfilling, crawl space drainage, vent/access wells, and rodent barriers.

6. The District reserves the right to view and approve relocatable prior to delivery. Building shall not be older than 15 years. NOTE: LEASED RELOCATABLE(S) TO BE BUILT NO LATER THAN 2011. ALL FINISHES TO BE IN GOOD WORKING CONDITION; SUBJECT TO DISTRICT REVIEW AND APPROVAL PRIOR TO SIGN-OFF. (Matrix Note)

7. **USED BUILDINGS:** Leased Relocatable(s) to be built no later than 2011. All finishes to be in good working condition. The District will accept buildings as old as 2011.

8. All buildings will be subject to review and approval prior to delivery.
9. All buildings shall include new carpet.
10. All buildings shall have LED lighting

11. Tariffs: In light of the imposition of tariffs, supply chain disruptions, increases in the cost of petroleum-based materials affected by the surge of oil prices, or other common potential price fluctuations (collectively, the “Common Price Fluctuation”), bidders shall account for these

Common Price Fluctuations in calculating their bids; the District will deny any change order request based on Common Price Fluctuations or any other factors that bidders could have anticipated in calculating their bids. Additionally, just-in-time procurement of materials, equipment, and labor may not be adequate due to Common Price Fluctuations and general pricing variability; accordingly, the District will require the successful bidders to develop and implement an early procurement plan for labor, equipment and materials, not just long-lead items. There shall be no additional cost to the District for Contractors developing and implementing the early procurement plan.

- END OF SPECIAL CONDITIONS-

**DRAWINGS
(ATTACHED HERETO)**

**LEASE OF RELOCATABLE BUILDINGS
BID NO. 2026/27-1FA**

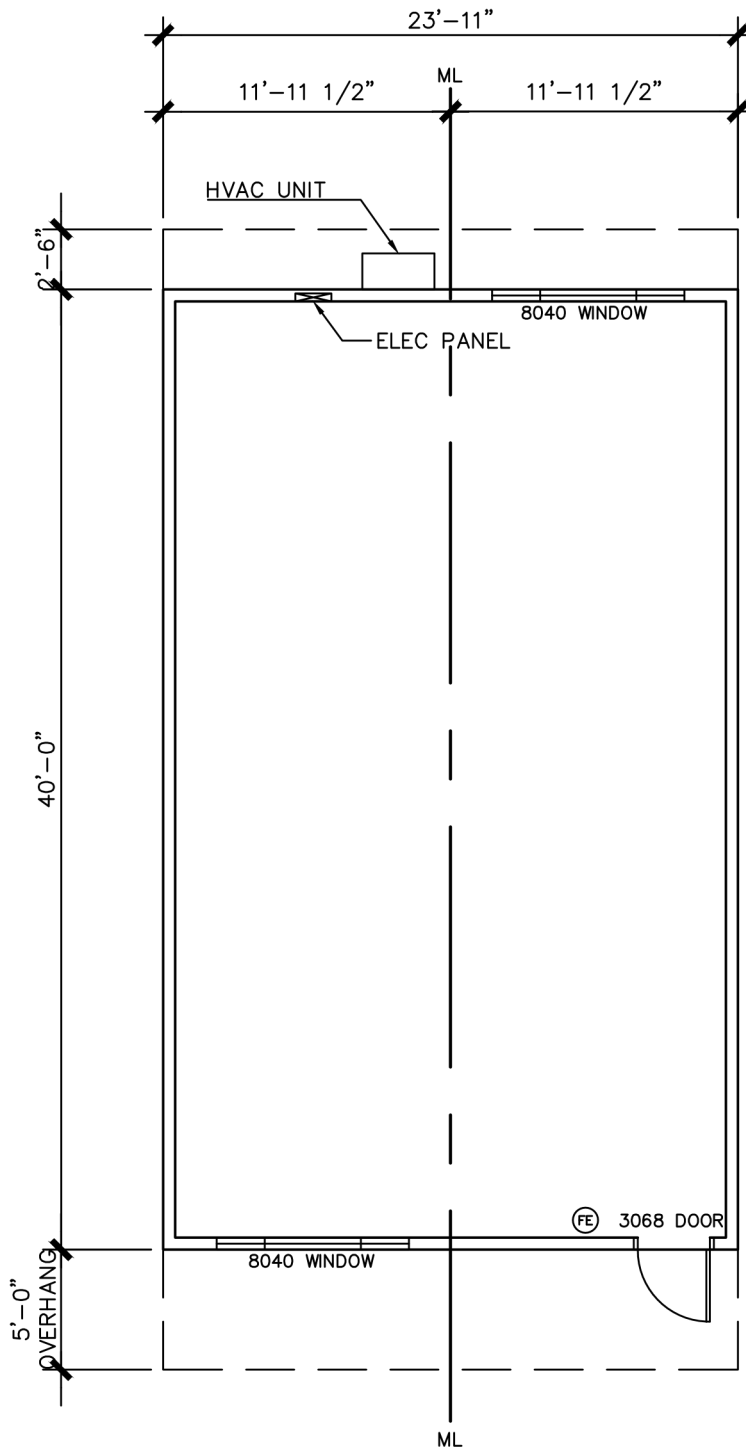

FRONT

AVAILABLE AS SHOWN - LEFT HAND
OR OPPOSITE HAND - RIGHT HAND

24 X 40 CLASSROOM	ITEM A
-------------------	--------

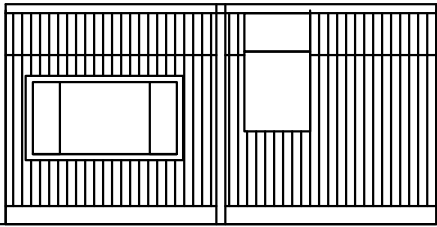

REAR ELEVATION

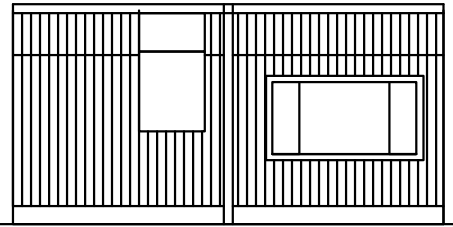

REAR ELEVATION

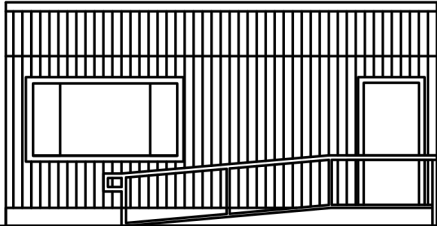

FRONT ELEVATION

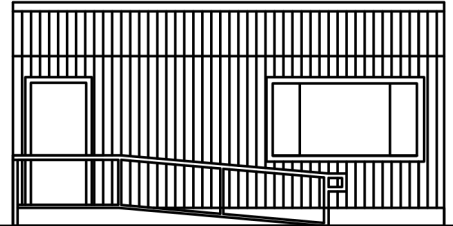

FRONT ELEVATION

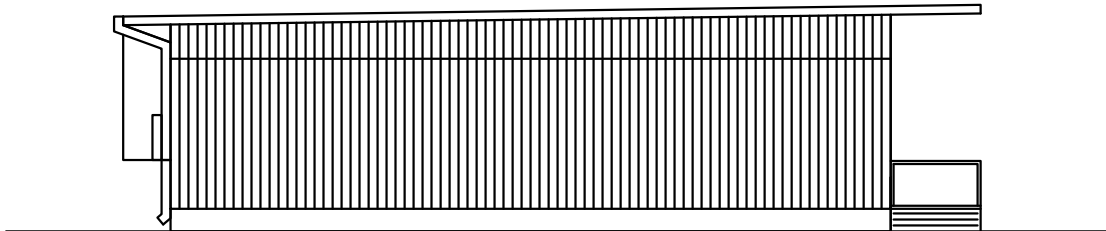

SIDE ELEVATION

24 x 40 CLASSROOM	ITEM A
--------------------------	---------------

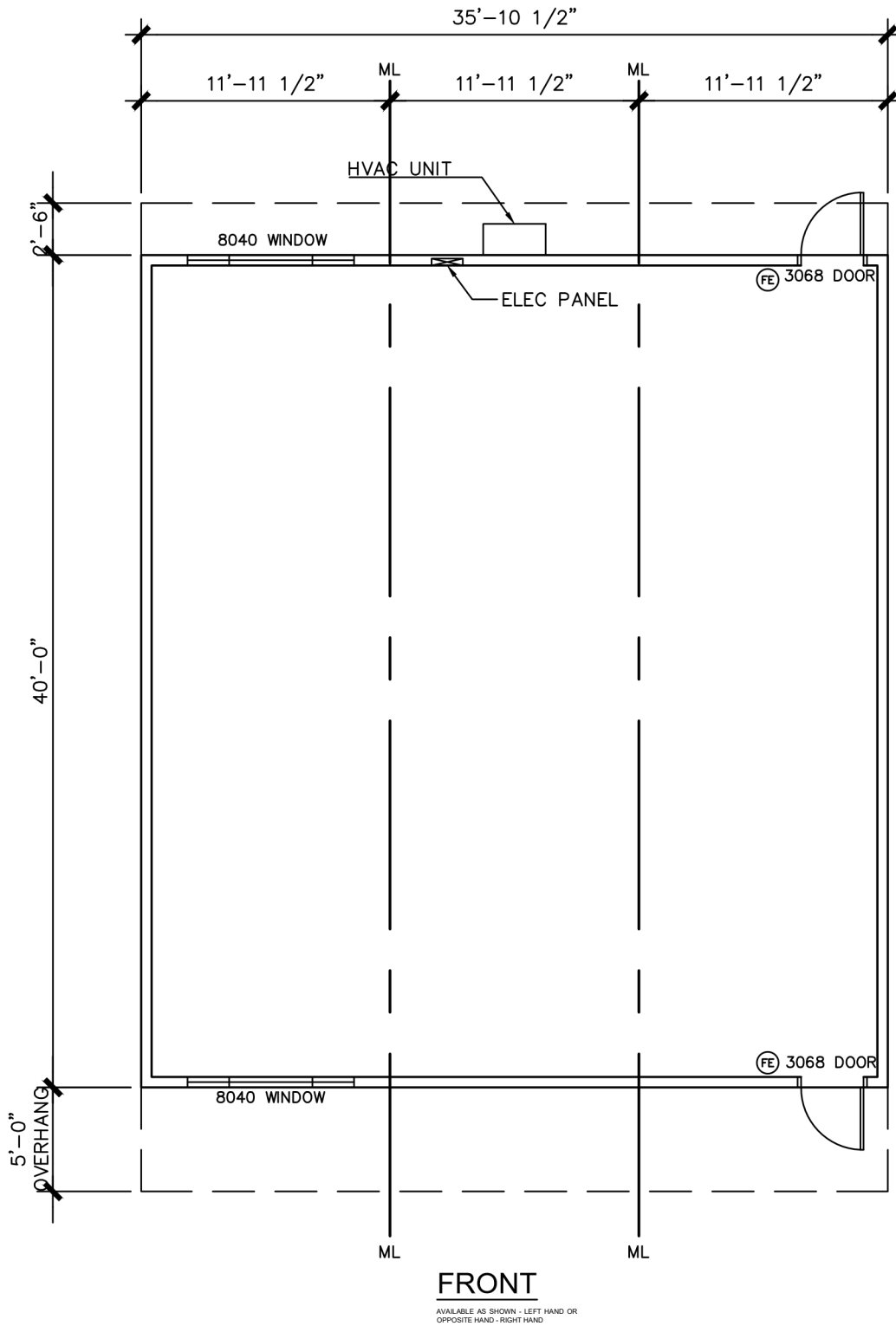

36 x 40 CLASSROOM	ITEM B
-------------------	--------

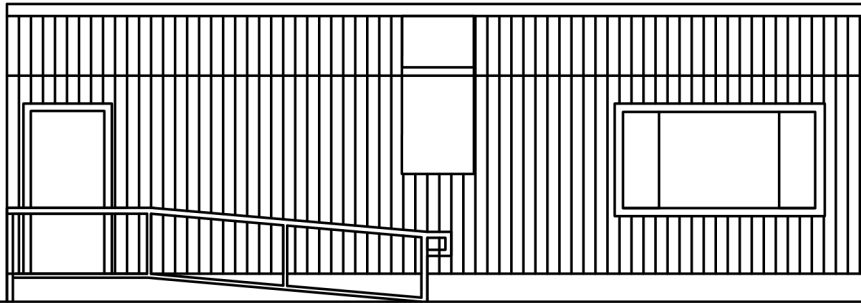

REAR ELEVATION

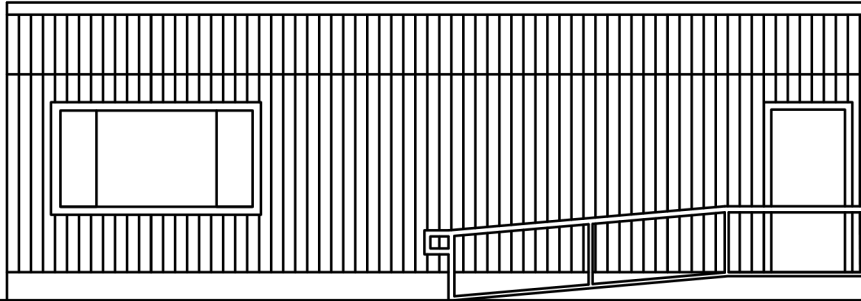

FRONT ELEVATION

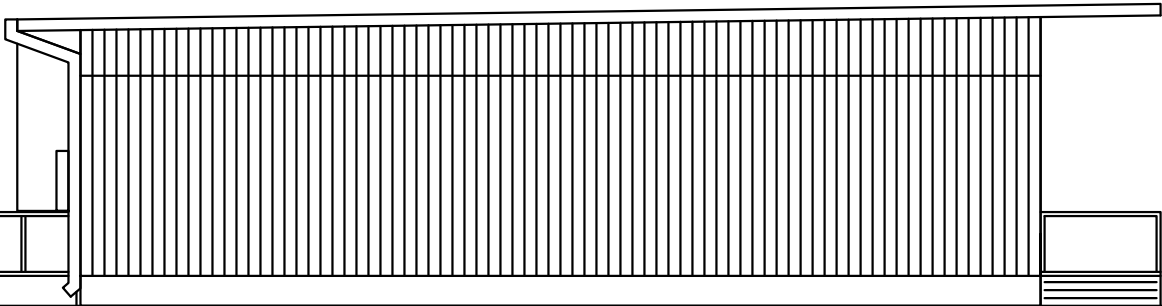

SIDE ELEVATION

36 x 40 CLASSROOM	ITEM B
--------------------------	---------------

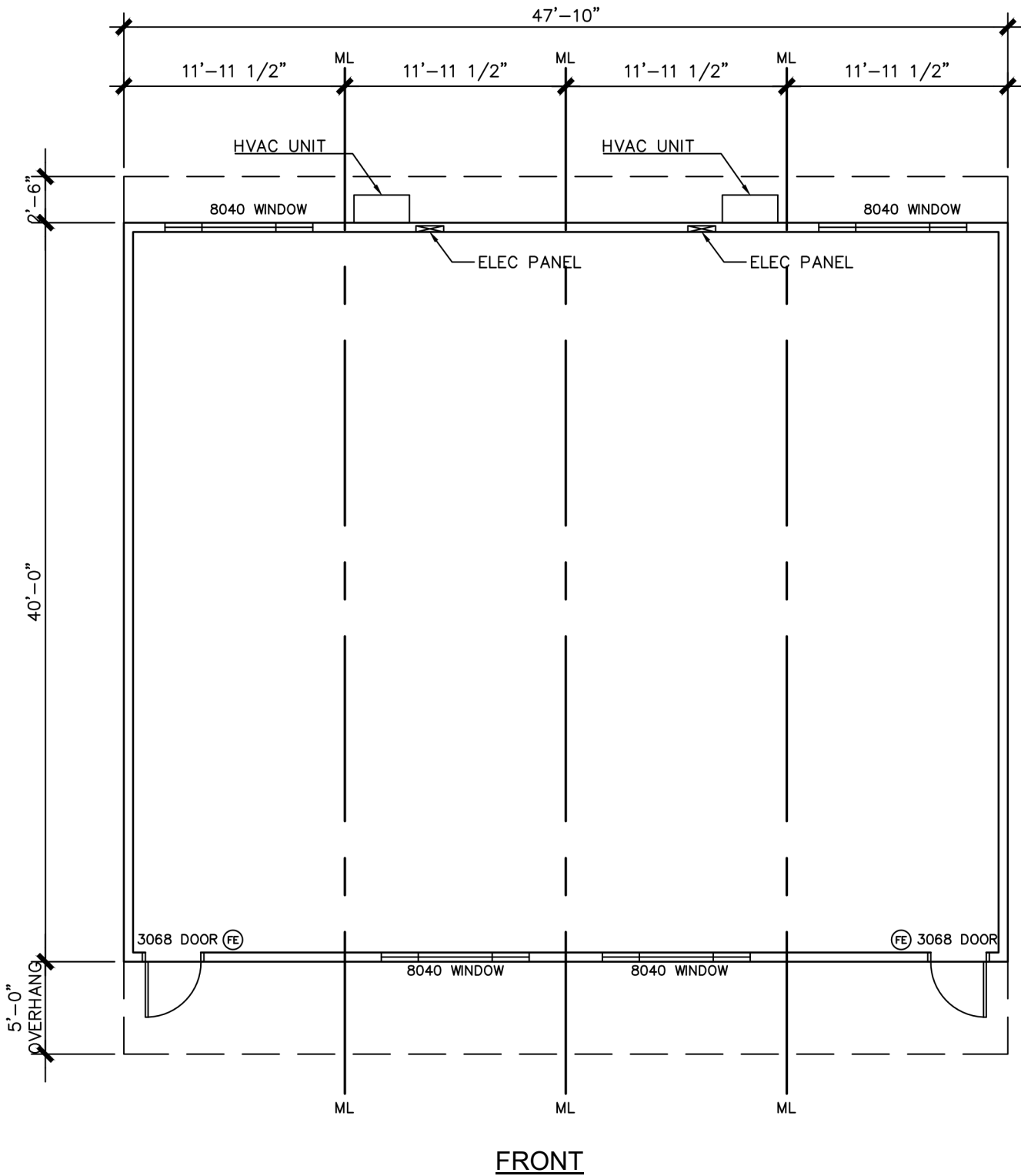

48 x 40 CLASSROOM	ITEM C
-------------------	--------

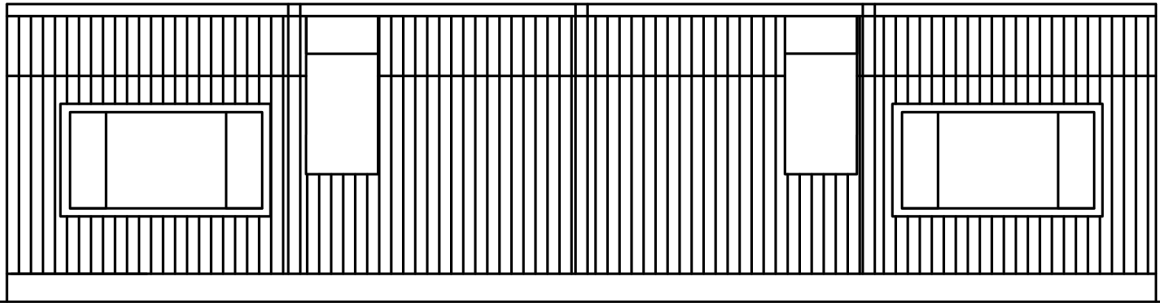

REAR ELEVATION

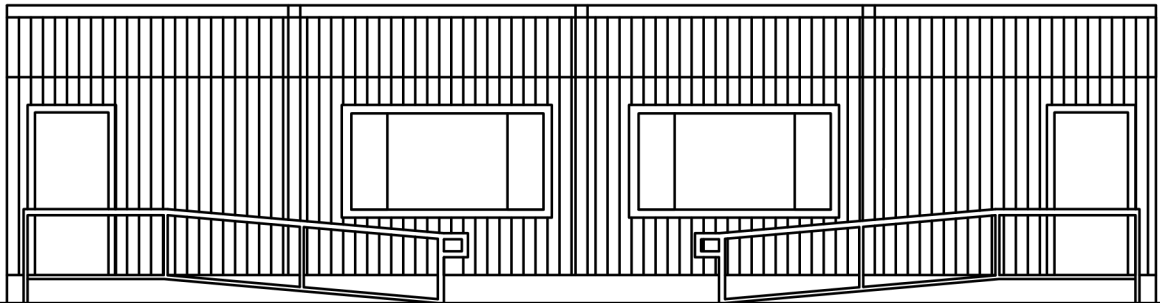

FRONT ELEVATION

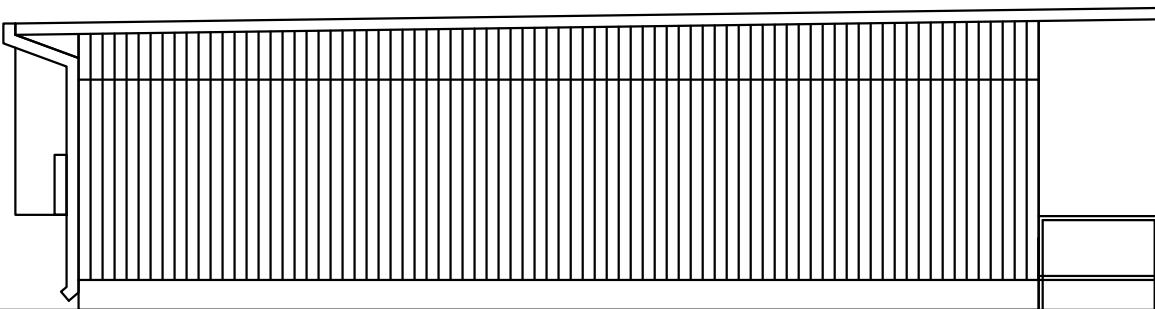

SIDE ELEVATION

48 x 40 CLASSROOM	ITEM C
--------------------------	---------------

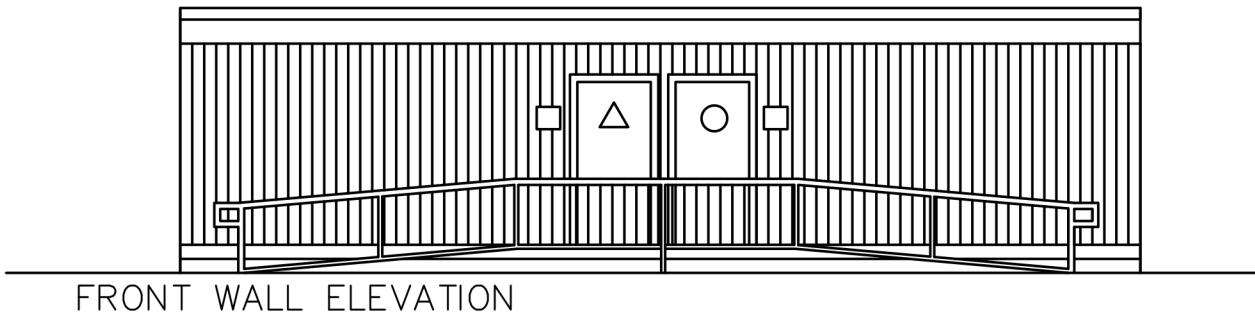
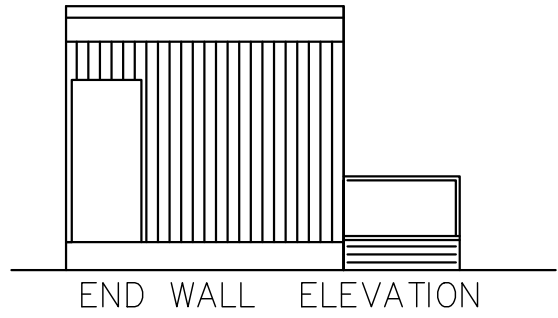
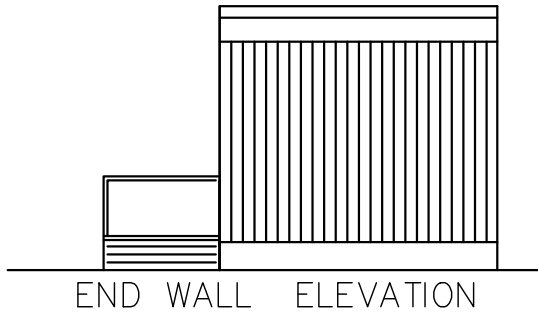

12 x 40 RESTROOM STUDENT	ITEM D
--------------------------	--------

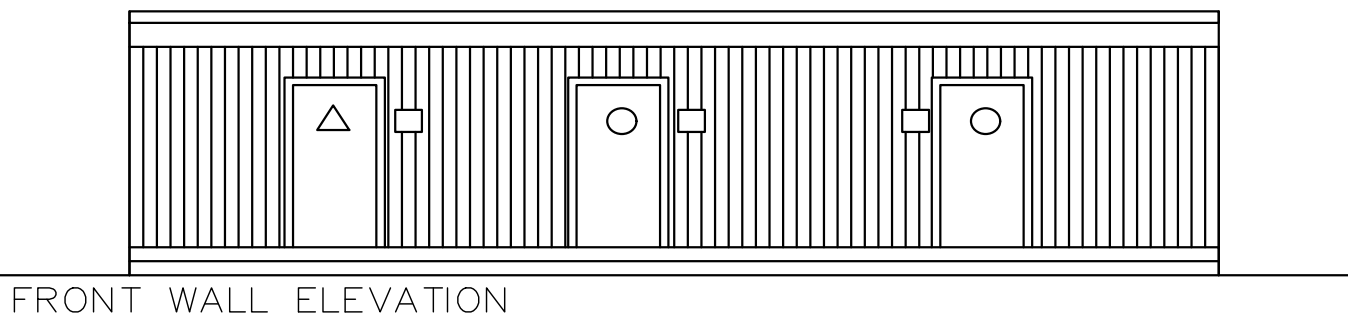
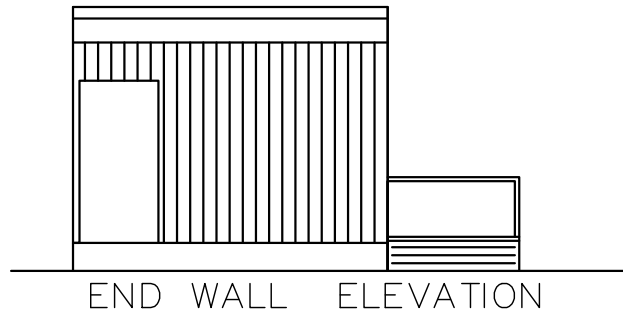
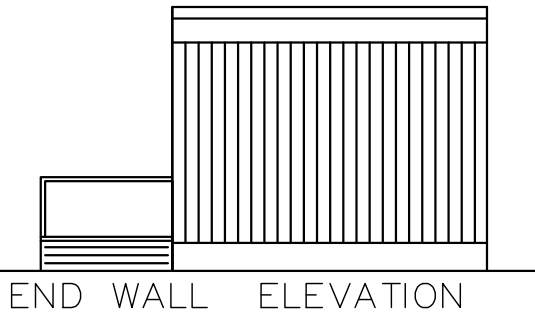
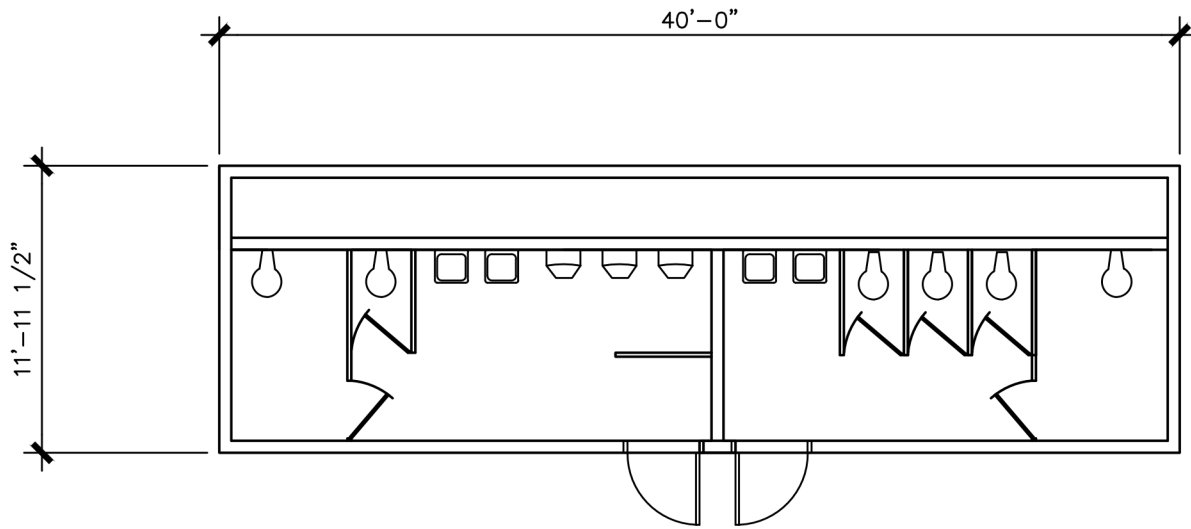

12 x 40 RESTROOM	ITEM E
------------------	--------

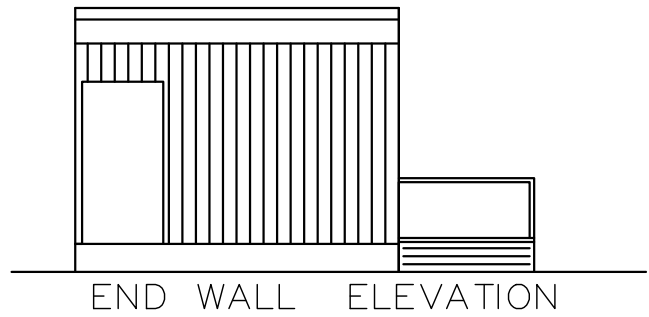
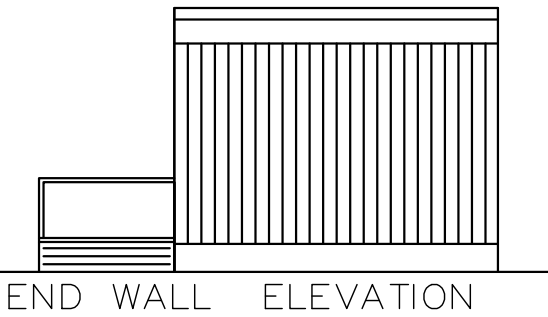
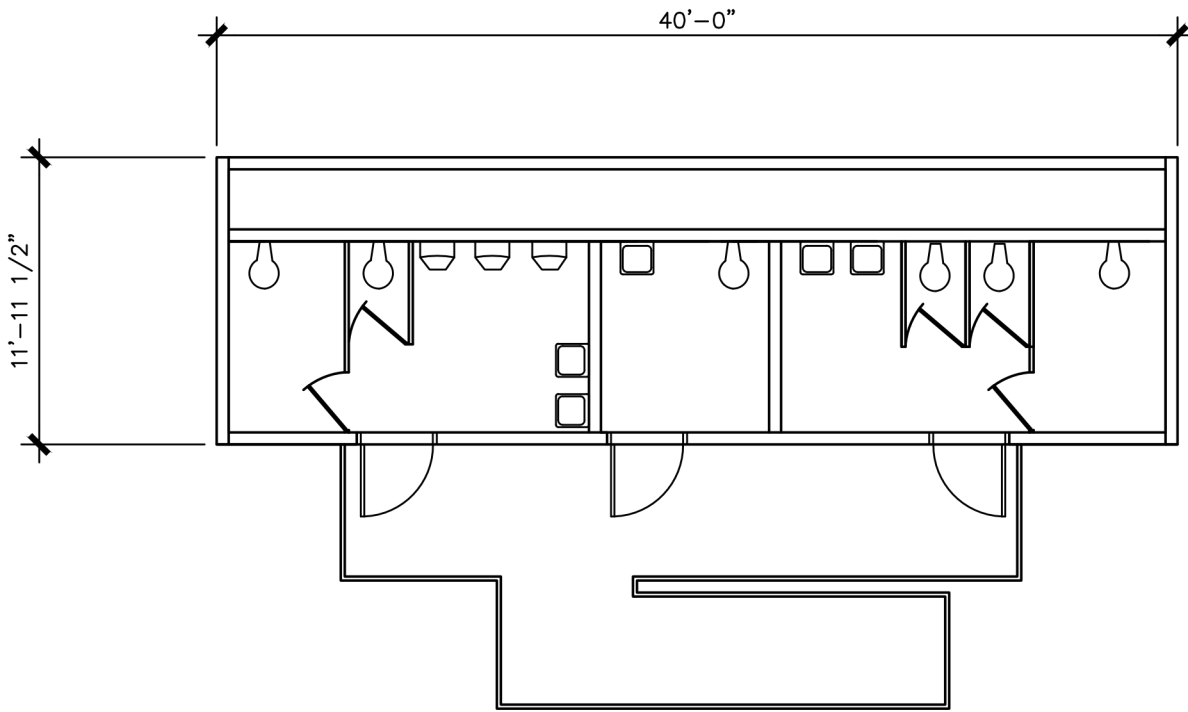

12 x 40 RESTROOM	ITEM F
------------------	--------

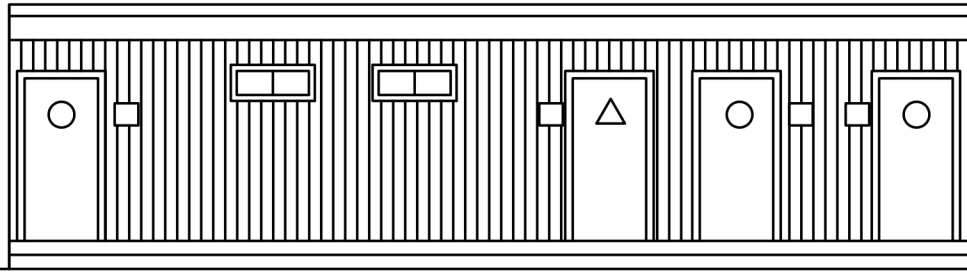

FRONT WALL ELEVATION

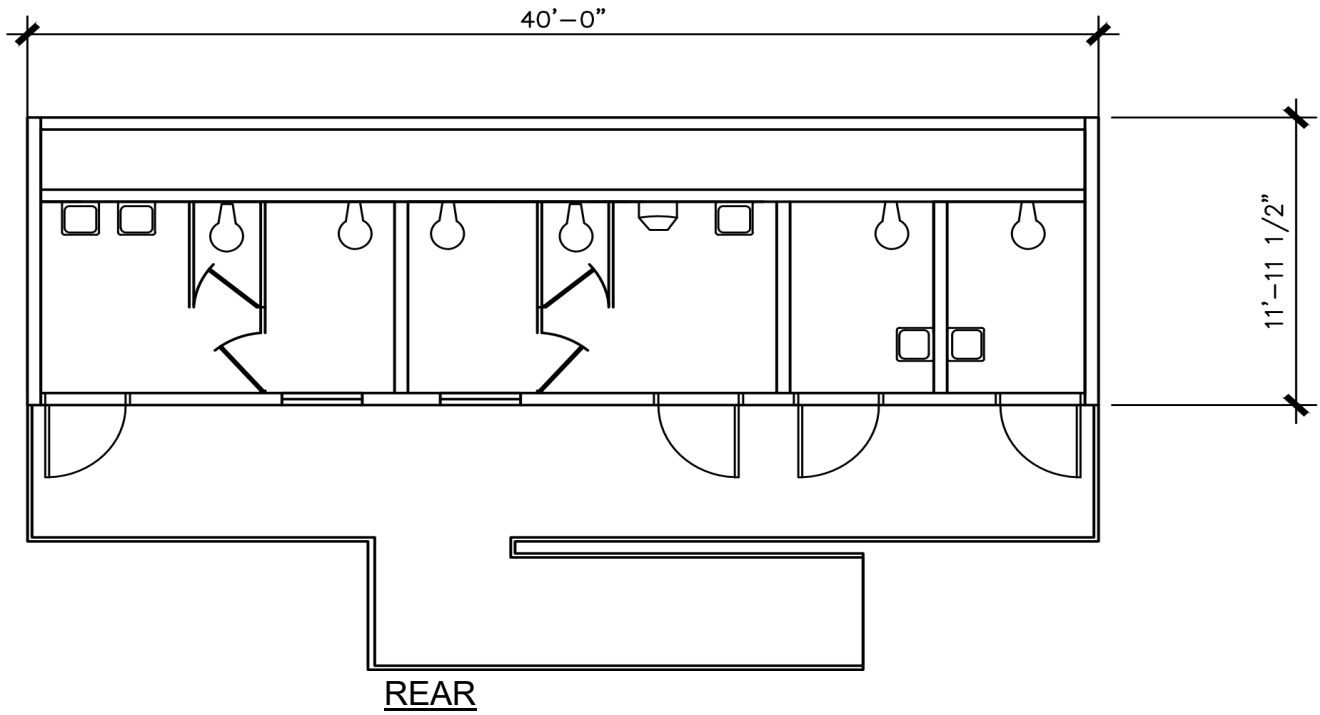

36 X 40 SCIENCE CLASSROOM	ITEM G
---------------------------	--------

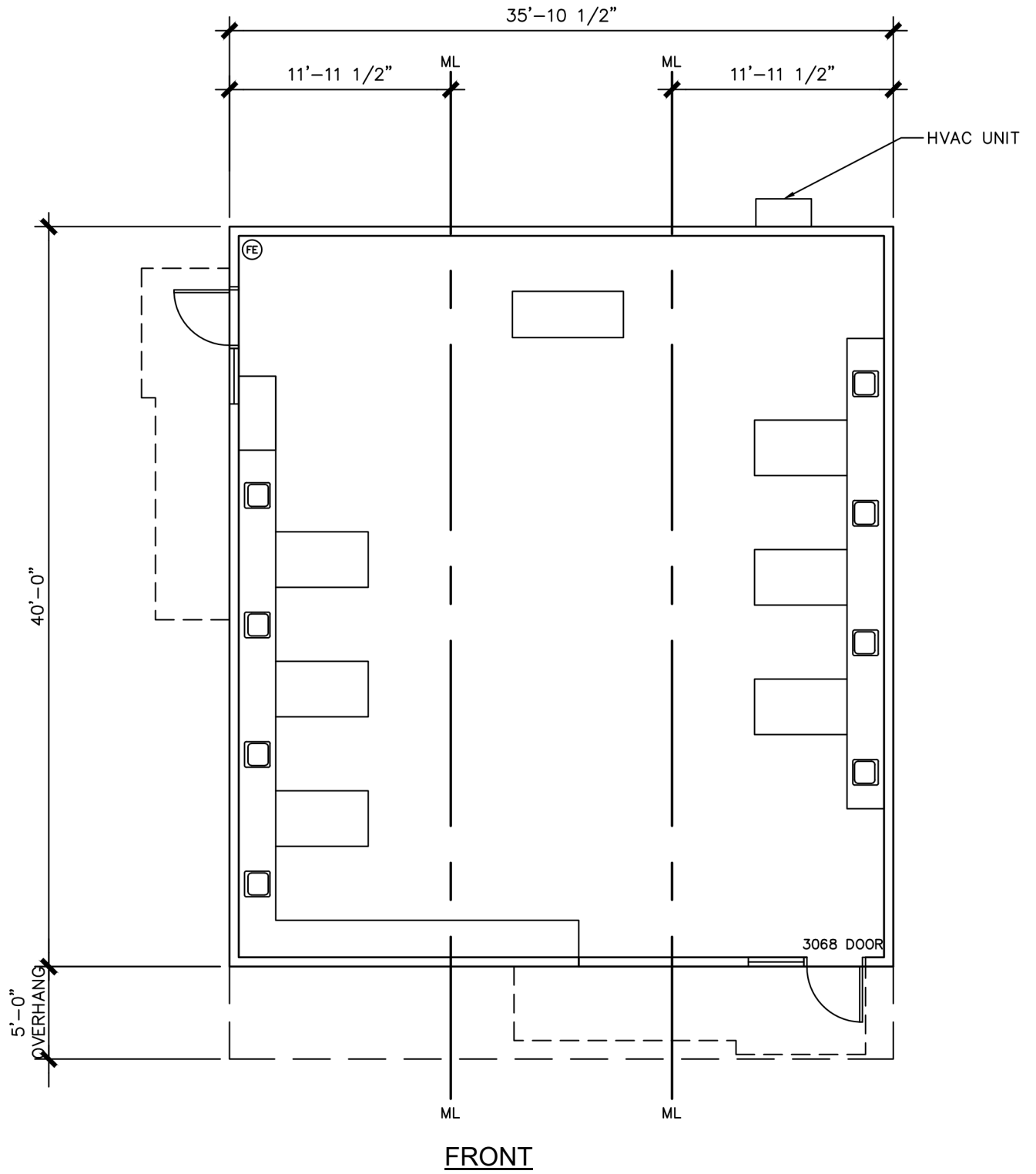

36 X 40 SCIENCE CLASSROOM	ITEM G
---------------------------	--------

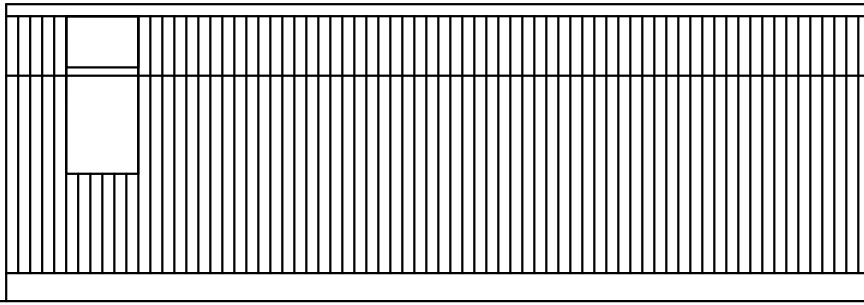

REAR ELEVATION

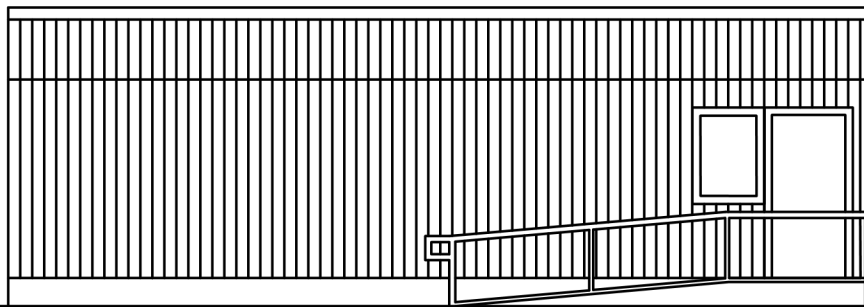

FRONT ELEVATION

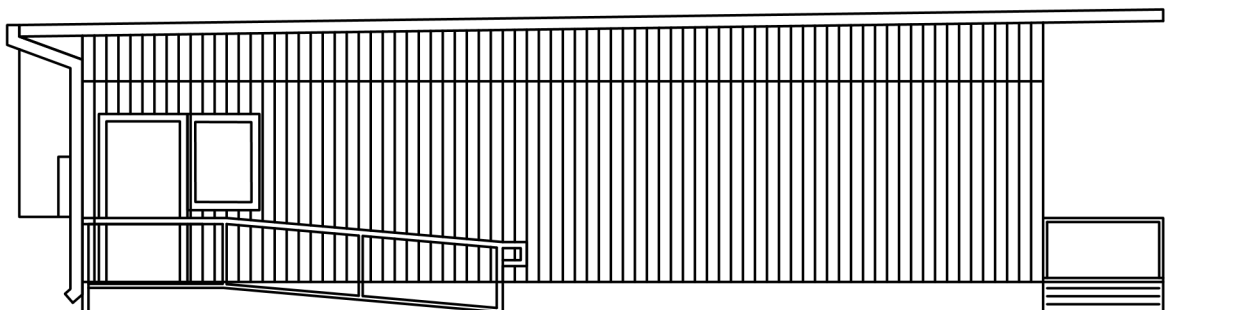

SIDE ELEVATION

REAR

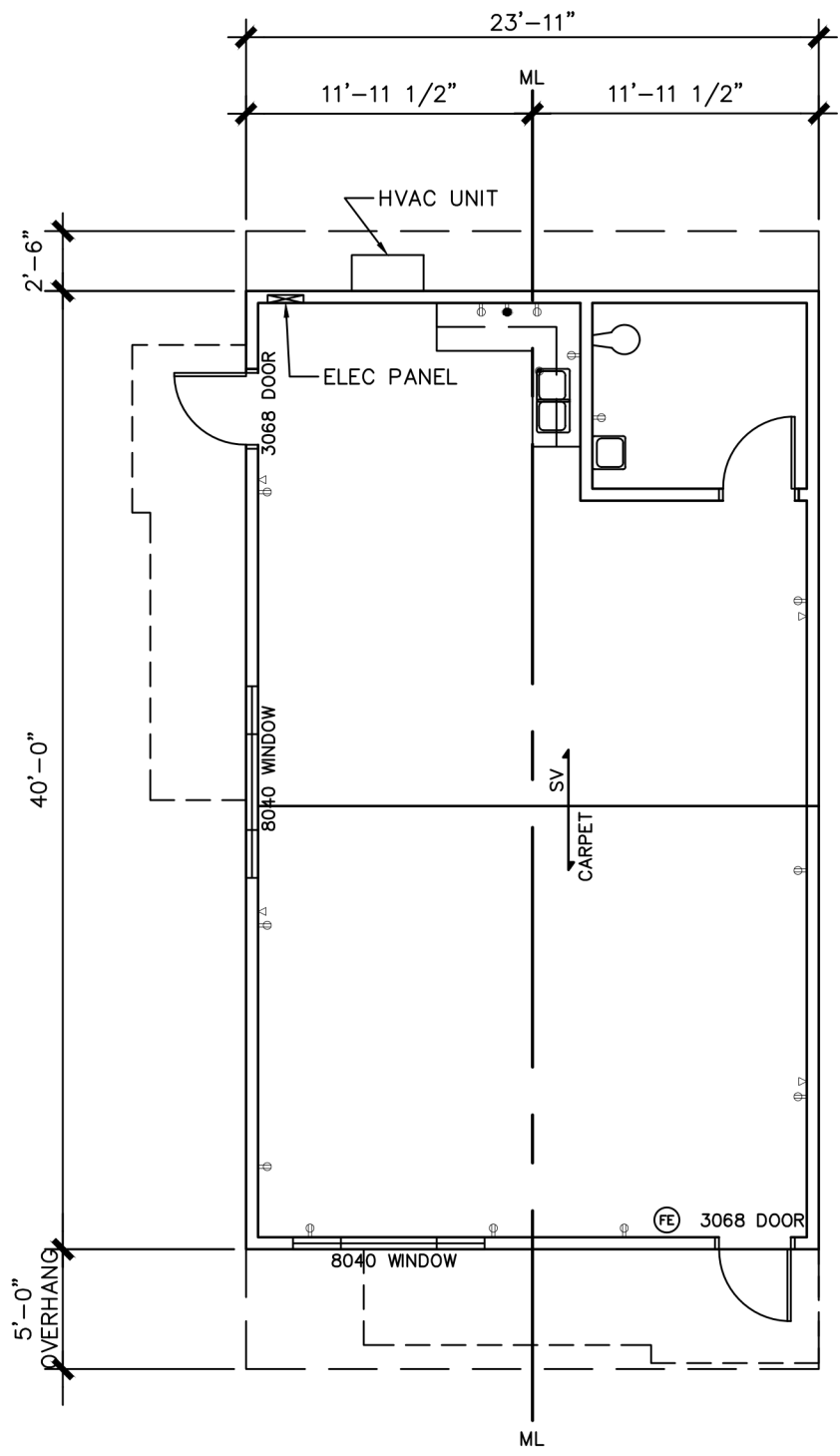

FRONT

AVAILABLE AS SHOWN - LEFT HAND
OR OPPOSITE HAND - RIGHT HAND

24 x 40 DAYCARE W/ RR	ITEM H
-----------------------	--------

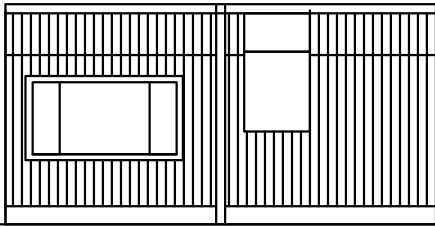

REAR ELEVATION

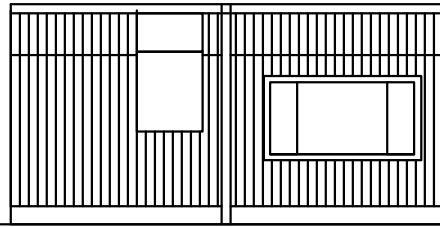

REAR ELEVATION

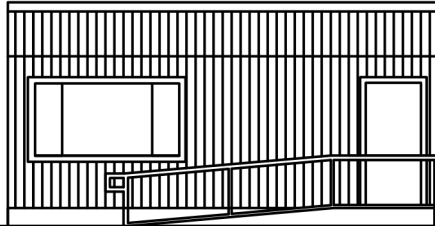

FRONT ELEVATION

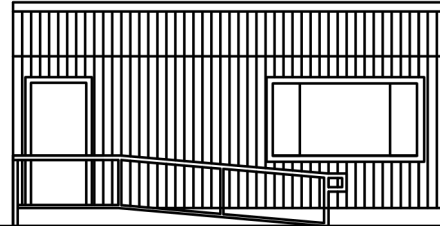

FRONT ELEVATION

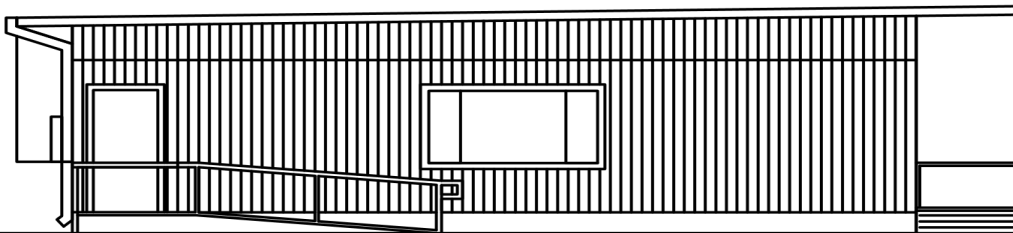

SIDE ELEVATION

24 x 40 DAYCARE W/ RR	ITEM H
-----------------------	--------

48 x 40 DAYCARE W/ RR	ITEM I
-----------------------	--------

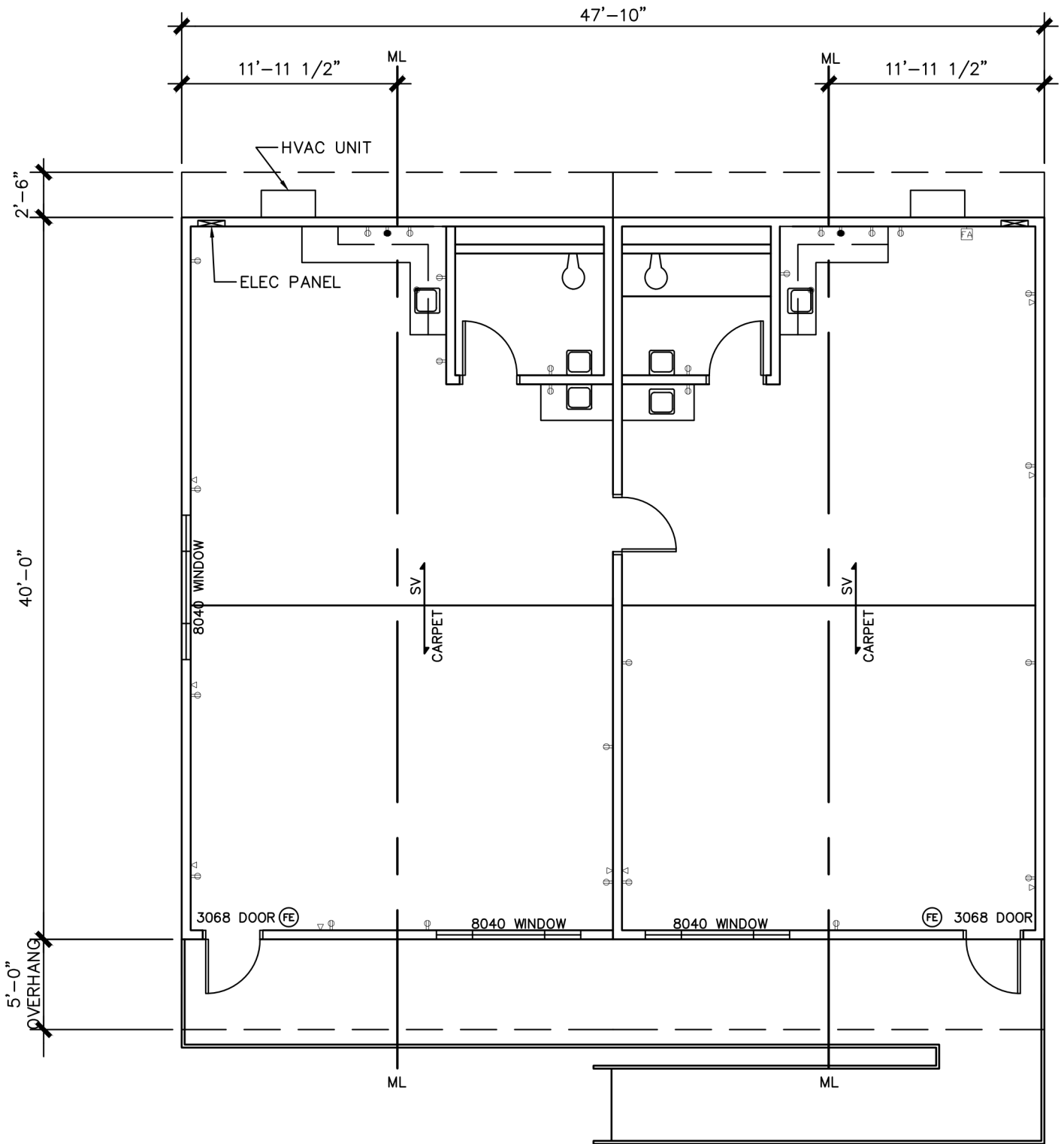

FRONT

AVAILABLE AS SHOWN - LEFT HAND
OR OPPOSITE HAND - RIGHT HAND

48 x 40 DAYCARE W/ RR	ITEM I
-----------------------	--------

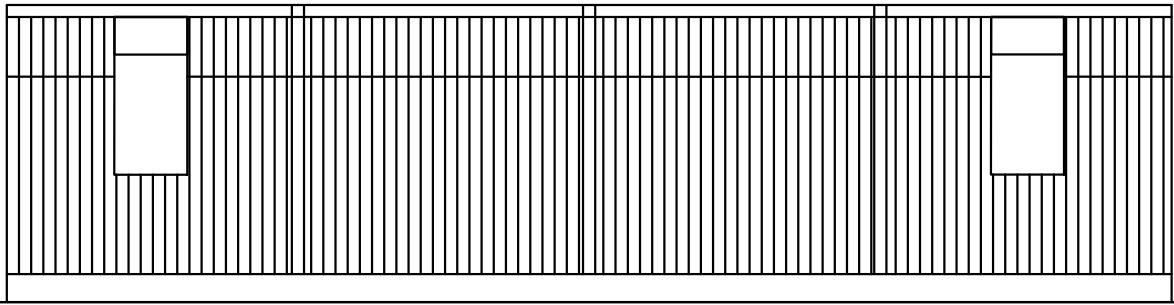

REAR ELEVATION

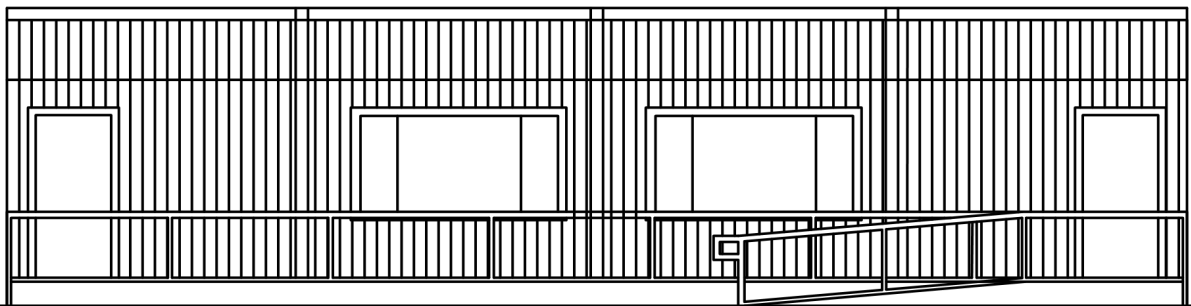

FRONT ELEVATION

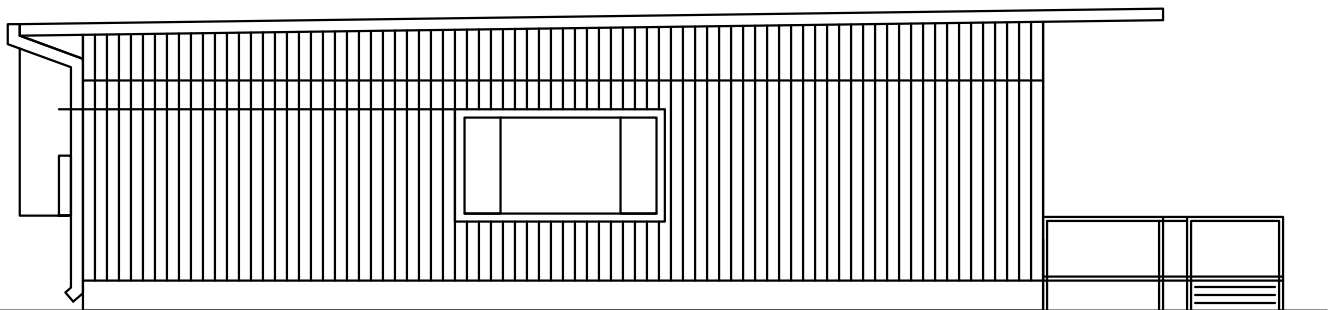

SIDE ELEVATION

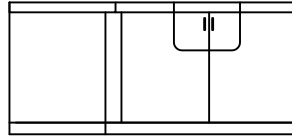
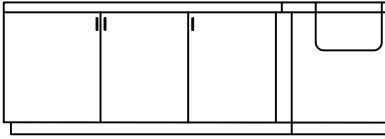
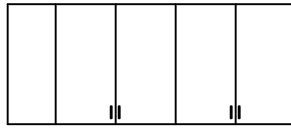
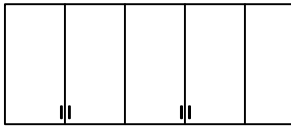

8' Counter Side View

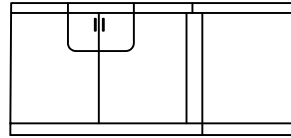
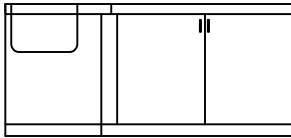
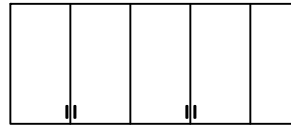
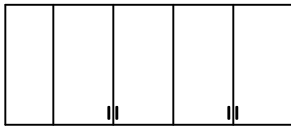

6' Counter

Side View

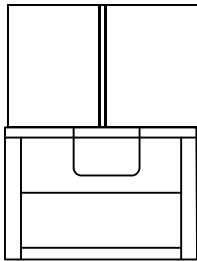

6' Counter ADA Accessible

48 x 40 DAYCARE W/ RR	ITEM I
-----------------------	--------