



# **IRVINE UNIFIED SCHOOL DISTRICT**

## **Bid No. 24/25-02MO, Unit Cost Pricing for Concrete**

**Bid Deadline: December 16, 2024 at 1:00 pm**

Contact: Maria Ragas  
Irvine Unified School District  
5050 Barranca Parkway, Irvine, CA 92604  
949-936-5212  
Email: [MariaRagas@iusd.org](mailto:MariaRagas@iusd.org)

**Bid No. 24/25-02MO, Unit Cost Pricing for Concrete**

**Table of Contents**

NOTICE CALLING FOR BIDS  
INFORMATION FOR BIDDERS  
\*BID FORM  
\*BID FORM PRICING SHEET  
\*BID BOND  
\*INFORMATION REQUIRED OF BIDDER  
\*DESIGNATION OF SUBCONTRACTORS  
\*NONCOLLUSION DECLARATION  
\*W-9 FORM  
+AGREEMENT  
+PAYMENT BOND  
+FAITHFUL PERFORMANCE BOND  
+WORKERS' COMPENSATION CERTIFICATE  
+DRUG-FREE WORKPLACE CERTIFICATION  
+CONTRACTOR'S CERTIFICATE REGARDING NON-ASBESTOS CONTAINING MATERIALS  
+TOBACCO USE POLICY  
NOTICE REGARDING CRIMINAL RECORDS CHECK (EDUCATION CODE SECTION 45125.1)  
+CRIMINAL RECORDS CHECK CERTIFICATION  
+DISTRICT RULES AND REGULATIONS  
+GUARANTEE  
ESCROW AGREEMENT FOR SECURITY DEPOSITS IN LIEU OF RETENTION  
SHOP DRAWING TRANSMITTAL  
EQUIPMENT/MATERIAL SOURCE INFORMATION (OPTIONAL)  
CHANGE ORDER (ADDITIVE)  
CHANGE ORDER (DEDUCTIVE)  
STATE OF CALIFORNIA – DEPARTMENT OF INDUSTRIAL RELATIONS  
DISABLED VETERAN BUSINESS ENTERPRISES CERTIFICATION  
SAMPLE CERTIFICATE OF INSURANCE & ENDORSEMENT  
APPENDIX A – SPECIFICATIONS  
APPENDIX B – SPECIAL CONDITIONS  
APPENDIX C – DRAWINGS  
APPENDIX D – GENERAL CONDITIONS

**\*Items must be completed, signed, and submitted as part of the bid. If required contract documents are not submitted the bidder will be declared non- responsive.**

**+Items which successful bidder must submit after the award.**

**NOTICE CALLING FOR BIDS**

District: **Irvine Unified School District**  
Bid Deadline: **December 16, 2024 at 1:00 pm**  
Place of Bid Receipt: **Irvine Unified School District  
Maintenance & Operations Office  
Attn: Joe Chapin  
100 Nightmist, Irvine, CA 92618**

NOTICE IS HEREBY GIVEN that the Irvine Unified School District of Orange County, California, acting by and through its Governing Board, hereinafter referred to as "DISTRICT," will receive up to, but not later than, the above-stated bid deadline, sealed bids at the place identified above for the award of a contract for **Bid No. 24/25-02MO, Unit Cost Pricing for Concrete.**

Project documents will be available on November 12, 2024 as a download at <https://iusd.org/about/departments/business-services/purchasing/current-bids-rfps>.

In accordance with the provisions of Business and Professions Code Section 7028.15 and Public Contract Code Section 3300, the DISTRICT requires that the bidder possess the following classification(s) of contractor's license at the time the bid is submitted: **CLASS B or C8**. Any bidder not so licensed at the time of the bid opening will be rejected as nonresponsive.

Questions regarding the bid must be received via e-mail to the attention of Maria Ragas at [MariaRagas@iusd.org](mailto:MariaRagas@iusd.org) by 11:00 am on December 2, 2024.

The DISTRICT reserves the right to reject any or all bids or to waive any irregularities or informalities in any bids or in the bidding process.

Effective April 1, 2015, all contractors and subcontractors must be registered with the DIR to submit a bid for a public works project pursuant to Labor Code section 1725.5.

The California Department of Industrial Relations has determined the general prevailing rates of per diem wages for the locality in which the work is to be performed for the Project. Copies of these wage rate determinations, entitled Prevailing Wage Scale, are available at the following website: [www.dir.ca.gov](http://www.dir.ca.gov). It shall be mandatory upon the successful bidder to whom the contract is awarded, and upon any subcontractor listed, to pay not less than the said specified rates to all workers employed by them for the Project.

No bidder may withdraw any bid for a period of **sixty (60)** calendar days after the date set for the opening of bids.

Pursuant to Public Contract Code Section 22300, the Agreement will contain provisions permitting the successful bidder to substitute securities for any monies withheld by the DISTRICT to ensure performance under the Agreement or permitting payment of retentions earned directly into escrow.

Irvine Unified School District  
Governing Board

By: Maria Ragas  
Supervisor, Purchasing & Contracts

Advertise: Orange County Register; November 10 & 17, 2024

## INFORMATION FOR BIDDERS

### WARNING:

READ THIS DOCUMENT CAREFULLY. DO NOT ASSUME  
THAT IT IS THE SAME AS OTHER SIMILAR DOCUMENTS  
YOU MAY HAVE SEEN, EVEN IF FROM THE SAME DISTRICT.

1. Preparation of Bid Form. Bids shall be submitted on the prescribed Bid Form, completed in full. All bid items and statements shall be properly and legibly filled out. Numbers shall be stated both in words and in figures where so indicated, and where there is a conflict in the words and the figures, the words shall control over the numbers. The signatures of all persons shall be in longhand and in ink. Prices, wording and notations must be in ink or typewritten.

2. Form and Delivery of Bids. The bid must conform and be responsive to all Project Documents and shall be made on the Bid Form provided, and the complete bid, together with any and all additional materials as required, shall be enclosed in a sealed envelope, addressed and hand delivered or mailed to the DISTRICT at: **100 Nightmist, Irvine, CA 92618**, and must be received on or before the bid deadline (Public Contract Code Section 20112) The envelope shall be plainly marked in the upper left hand corner with the bidder's name, the Project designation and the date and time for the opening of bids. **It is the bidder's sole responsibility to ensure that its bid is received prior to the bid deadline.** In accordance with Government Code Section 53068, any bid received after the scheduled closing time for receipt of bids shall be returned to the bidder unopened. At the time and place set forth for the opening of bids, the sealed bids will be opened and publicly read aloud. However, if prequalification of bidders is required pursuant to Public Contract Code Section 20111.5 only those sealed bids received from prequalified bidders shall be opened and publicly read aloud.

3. Bid Security. Each bid shall be accompanied by a bid security in the form of cash, a certified or cashier's check or bid bond in the amount of not less than **ten percent (10%)** of the total bid price payable to the DISTRICT and shall be given as a guarantee that the bidder, if awarded the contract, will execute the Agreement within **five (5)** working days after Notice of Award of the contract, and will furnish certificates and endorsements evidencing that the required insurance is in effect, the Workers' Compensation Certificate, Drug-Free Work Place Certification, the Criminal Records Check Certification, Contractor's Certificate Regarding Non-Asbestos Containing Materials, and the Disabled Veteran Business Enterprises Certification, if applicable, all within **five (5)** working days of the notice of award of the contract or as otherwise requested in writing by the DISTRICT. It is understood and agreed that should bidder fail or refuse to return these documents as required by the DISTRICT, the bid security shall be forfeited to the DISTRICT. If the Bidder elects to furnish a bid bond as its Bid Security, the Bidder shall use the bid bond form included in the Project Documents.

4. Signature. Any signature required on Project Documents must be signed in the name of the bidder and must bear the signature of the person or persons duly authorized to sign these documents. Where indicated, if bidder is a corporation, the legal name of the corporation shall first be set forth, together with two signatures: one from among the chairman of the board, president or vice president and one from among the secretary, chief financial officer, or treasurer.

Alternatively, the signature of other authorized officers or agents may be affixed, if duly authorized by the corporation. Such documents shall include the title of such signatories below the signature and shall bear the corporate seal. Where indicated, in the event that the bidder is a joint venture or partnership, there shall be submitted with the bid certifications signed by authorized officers of each of the parties to the joint venture or partnership, naming the individual who shall sign all necessary documents for the joint venture or partnership and, should the joint venture or partnership be the successful bidder, who shall act in all matters relative to the Project for the joint venture or partnership. If bidder is an individual, his/her signature shall be placed on such documents.

5. Modifications. Changes in or additions to any of the bid documents, summary of the work bid upon, alternative proposals, or any other modifications which are not specifically called for by the DISTRICT may result in the DISTRICT'S rejection of the bid as being nonresponsive. No oral, telephonic, facsimile or electronic modification of any of the bid documents will be considered.

6. Erasures, Inconsistent or Illegible Bids. The bid submitted must not contain any erasures, interlineations, or other corrections unless each such correction is authenticated by affixing the initials of the person(s) signing the bid in the margin immediately adjacent to the correction. In the event of inconsistency between words and numbers in the bid, words shall control numbers. In the event that DISTRICT determines that any bid is unintelligible, illegible or ambiguous, the DISTRICT may reject such bid as being nonresponsive.

7. Examination of Site and Project Documents. At its own expense and prior to submitting its bid, each bidder shall examine all documents relating to the Project; visit the site and determine the local conditions which may in any way affect the performance of the work, including the general prevailing rates of per diem wages and other relevant cost factors; familiarize itself with all Federal, State and Local laws, ordinances, rules, regulations and codes affecting the performance of the work, including the cost of permits and licenses required for the work; make such surveys and investigations, including investigation of subsurface or latent physical conditions at the site or where work is to be performed, as it may deem necessary for performance of the work at its bid price ; determine the character, quality, and quantities of the work to be performed and the materials and equipment to be provided; and correlate its observations, investigations, and determinations with all requirements of the Project . The Project Documents show and describe the existing conditions as they are believed to have been used in the design of the work and are only provided as information for the bidder. The DISTRICT is not making any warranties regarding said information. The DISTRICT shall not be liable for any loss sustained by the successful bidder resulting from any variance between the conditions and design data given in the Project Documents and the actual conditions revealed during the bidder's pre-bid examination or during the progress of the work. **Bidder agrees that the submission of a bid shall be incontrovertible evidence that the bidder has complied with all the requirements of this provision of the Information for Bidders.**

8. Withdrawal of Bids. Any bid may be withdrawn, either personally or by written request signed by the bidder, at any time prior to the scheduled closing time for receipt of bids. The bid security for a bid withdrawn prior to the scheduled closing time for receipt of bids, in

accordance with this paragraph, shall be returned. No bidder may withdraw any bid for a period of **sixty (60)** calendar days after the date set for the opening of bids.

9. Agreement and Bonds. The Agreement, which the successful bidder will be required to execute is included in the bid documents and should be carefully examined by the bidder. The complete Agreement consists of the following but not limited to the Notice Calling for Bids, Information for Bidders, Bid Form, Bid Form Pricing Sheet, Noncollusion Declaration, Bid Bond, Tobacco Use of Policy, Workers' Compensation Certificate, Drug-Free Workplace Certification, Contractor's Certificate Regarding Non-Asbestos Containing Materials, Criminal Records Check Certification, District Rules and Regulations, Guarantee, Extract of Public Works Contract Award, Disabled Veteran Business Enterprises Certification, General Conditions, Special Conditions, Specifications, Drawings, W-9, all insurance requirements, any and all change orders, modifications, addenda and amendments, if any (hereinafter Bid Documents), thereof duly incorporated therein. All of above documents are intended to cooperate and be complementary so that any instructions or requirements called for in one and not mentioned in the other, or vice versa, are to be executed the same as if mentioned in all said documents. The intention of the documents is to include all labor, materials, equipment, transportation and services necessary for the proper delivery of all items called for in the Agreement.

10. Interpretation of Project Documents. If any bidder is in doubt as to the true meaning of any part of the Project Documents, or finds discrepancies in, or omissions from the Project Documents, a written request for an interpretation or correction thereof must be submitted to the DISTRICT via email to the attention of **Maria Ragas at [MariaRagas@iusd.org](mailto:MariaRagas@iusd.org) by December 2, 2024 at 11:00 am.** No requests shall be considered after this time. The bidder submitting the written request shall be responsible for its prompt delivery. Any interpretation or correction of the Project Documents will be made solely at DISTRICT's discretion and only by written addendum duly issued by the DISTRICT, and a copy of such addendum will be hand delivered or mailed or faxed to each bidder known to have received a set of the Project Documents. No person is authorized to make any oral interpretation of any provision in the Project Documents, nor shall any oral interpretation of Project Documents be binding on the DISTRICT. If there are discrepancies of any kind in the Project Documents, the interpretation of the DISTRICT shall prevail. **SUBMITTAL OF A BID WITHOUT A REQUEST FOR CLARIFICATIONS SHALL BE INCONTROVERTIBLE EVIDENCE THAT THE BIDDER HAS DETERMINED THAT THE PROJECT DOCUMENTS ARE ACCEPTABLE AND SUFFICIENT FOR BIDDING AND COMPLETING THE WORK; THAT BIDDER IS CAPABLE OF READING, FOLLOWING AND COMPLETING THE WORK IN ACCORDANCE WITH THE PROJECT DOCUMENTS; AND THAT BIDDER AGREES THAT THE PROJECT CAN AND WILL BE COMPLETED ACCORDING TO THE DISTRICT'S TIMELINES AND ACCORDING TO THE PROGRESS SCHEDULE TO BE SUBMITTED BY THE SUCCESSFUL BIDDER INCORPORATING THE DISTRICT'S TIMELINES FOR COMPLETION OF THE PROJECT.**

11. Bidders Interested in More Than One Bid. No person, firm or corporation shall be allowed to make, or file, or be interested in more than one bid for the same work unless alternate bids are specifically called for by the DISTRICT. A person, firm, or corporation that has submitted a subproposal to a bidder, or that has quoted prices of materials to a bidder, is not thereby disqualified from submitting a proposal or quoting prices to other bidders or submitting a bid on the Project.

12. Award of Contract. The DISTRICT reserves the right to reject any or all bids, or to waive any irregularities or informalities in any bids or in the bidding process. The award of the contract, if made by the DISTRICT, will be by action of the Governing Board and to the lowest responsive and responsible bidder. The DISTRICT will determine low bid by the 'base bid' which will be the '*Total Bid Amount*' from Bid Form page 1. If two identical low bids are received from responsive and responsible bidders, the DISTRICT will determine which bid will be accepted pursuant to Public Contract Code Section 20117. In the event an award of the contract is made to a bidder, and such bidder fails or refuses to execute the Agreement and provide the required documents within **five (5)** working days after the notice of award of the contract to bidder, the DISTRICT may award the contract to the next lowest responsive and responsible bidder or reject all bidders.

13. Alternate Bids. Not Applicable.

14. Competency of Bidders. In selecting the lowest responsive and responsible bidder, consideration will be given not only to the financial standing but also to the general competency of the bidder for the performance of the Project. By submitting a bid, each bidder agrees that the DISTRICT, in determining the successful bidder and its eligibility for the award, may consider the bidder's experience and facilities, conduct and performance under other contracts, financial condition, reputation in the industry, and other factors which could affect the bidder's performance of the Project. To this end, each bid shall be supported by a statement of the bidder's experience on the form entitled "INFORMATION REQUIRED OF BIDDER."

The DISTRICT may also consider the qualifications and experience of subcontractors and other persons and organizations (including those who are to furnish the principal items of material and equipment) proposed for those portions of the work. Operating costs, maintenance considerations, performance data and guarantees of materials and equipment may also be considered by the DISTRICT. In this regard, the DISTRICT may conduct such investigations as the DISTRICT deems necessary to assist in the evaluation of any bid and to establish the responsibility, qualifications and financial ability of the bidder, proposed subcontractors, and other persons and organizations to do the work to the DISTRICT's satisfaction within the prescribed time. The DISTRICT reserves the right to reject the bid of any bidder who does not pass any such evaluation to the satisfaction of the DISTRICT.

15. Listing Subcontractors. Each bidder shall submit, on the form furnished with the Project Documents, a list of the proposed subcontractors on this Project as required by the Subletting and Subcontracting Fair Practices Act (Public Contract Code Section 4100, et seq.). If alternate bids are called for and the bidder intends to use different or additional subcontractors, a separate list of subcontractors must be submitted for each such alternate bid. If the bidder fails to specify a subcontractor for any portion of the work in excess of one half (1/2) of one percent (1%) of the bidder's total bid, the bidder agrees that he/she is fully qualified to perform that work and agrees to perform that portion of the work. Violation of this requirement (including the procurement of a subcontractor for the Project if no subcontractor is specified) can result in the DISTRICT invoking the remedies of Public Contract Code Sections 4110 and 4111.

16. Insurance and Workers' Compensation. The successful bidder shall be required to furnish certificates and endorsements evidencing that the required insurance is in effect as set forth



in the Agreement. District may request that such certificates and endorsements are completed on District provided forms. In accordance with the provisions of Section 3700 of the Labor Code, the successful bidder shall secure the payment of compensation to all employees. The successful bidder who has been awarded the contract shall sign and file with District prior to performing the work, the Workers' Compensation Certificate included as a part of the proposal documents. Labor Code section 1861.

a. Successful bidder shall, at bidder's sole cost and expense, maintain in full force and effect the following insurance coverages from a California licensed insurer with an A, VIII, or better rating from A.M. Best or an approved self-insurance program, sufficient to cover any claims, damages, liabilities, costs and expenses (including attorney fees) arising out of or in connection with bidder's fulfillment of the obligations under this bid:

i. Comprehensive General Liability Insurance, including bodily injury, property damage and contractual liability with minimum limits set by the DISTRICT. The policy may not contain an exclusion for sexual molestation or abuse coverage, may be waived by the District.

(a)	General Aggregate	\$2,000,000
(b)	Each Occurrence	\$1,000,000
(c)	Products/Completed Operations	\$1,000,000
(d)	Personal and Advertising Injury	\$1,000,000
(e)	Damage to Rented Premises	\$50,000
(f)	Medical Expense (any one person)	\$5,000

ii. Umbrella (excess) liability insurance coverage with a limit of \$3,000,000, unless waived by the DISTRICT. The policy may not contain an exclusion for sexual molestation or abuse coverage, may be waived by the District.

iii. Business Automobile Liability Insurance for owned, scheduled, non-owned, or hired automobiles with a combined single limit not less than \$1,000,000 per occurrence. (Required only if the bidder drives on behalf of the DISTRICT in the course of performing Services.)

iv. Professional Liability Insurance with a limit of \$1,000,000 per occurrence, unless waived by the DISTRICT and if applicable.

v. Workers' Compensation and Employers Liability Insurance in a form and amount covering bidder's full liability under the California Workers' Compensation Insurance and Safety Act and in accordance with applicable state and federal laws. The policy shall be endorsed with the insurer's waiver of rights of subrogation against the DISTRICT.

It should be expressly understood, however, that the coverage and limits referred to under i., ii., iii., and iv. above shall not in any way limit the liability of the bidder.



b. No later than five (5) days from execution of the Agreement by the DISTRICT and successful bidder, and prior to commencing the Services under this bid, bidder shall provide DISTRICT with certificates of insurance evidencing all coverages and endorsements required hereunder.

Successful bidder shall provide prior written notice to the DISTRICT thirty (30) days in advance of any non-renewal, cancellation, or modification of the required insurance. The certificates of insurance providing the coverages referred to in clauses i. and ii. above shall name DISTRICT, its Governing Board, officers, and employees, as additional insureds with appropriate endorsements. In addition, the certificates of insurance shall include a provision stating "Such insurance as is afforded by this policy shall be primary, and any insurance carried by DISTRICT shall be excess and noncontributory." Failure to maintain the above mentioned insurance coverages shall be cause for termination of the Agreement.

17. Contractor's License. If, at the time and date of the bid opening, bidder is not properly licensed to perform the Project in accordance with Division 3, Chapter 9, of the Business and Professions Code and the Project Documents, such bid will be rejected as nonresponsive. (Public Contract Code Section 3300) Pursuant to Business and Professions Code Section 7028.15, no payment shall be made for work or materials under the contract unless and until the Registrar of Contractors verifies to the DISTRICT that the bidder was properly licensed at the time the bid was submitted. Any bidder not so licensed is subject to penalties under the law and the contract will be considered void and DISTRICT shall have the right to bring an action against the unlicensed bidder awarded the contract for recovery of all compensation paid under the contract. (Business and Professions Code Section 7031(b)) If the license classification specified hereinafter is that of a "specialty contractor" as defined in Section 7058 of the Business and Professions Code, the specialty contractor awarded the contract for this work shall construct a majority of the work, in accordance with the provisions of Business and Professions Code Section 7059. The bidder may not use the contractor license of a third party for this bid.

18. Anti-Discrimination. In connection with all work performed under this Project, there shall be no unlawful discrimination against any prospective or active employee engaged in the work because of race, color, ancestry, national origin, religious creed, sex, age, marital status, physical disability, mental disability, or medical condition. The successful bidder agrees to comply with applicable Federal and State laws including, but not limited to, the California Fair Employment and Housing Act, beginning with Government Code Section 12900 and Labor Code Section 1735. In addition, the successful bidder agrees to require like compliance by any subcontractors employed on the Project by such bidder.

19. Hold Harmless and Indemnification. The successful bidder awarded the contract will be required to indemnify and hold harmless the DISTRICT, its Governing Board, officers, agents, and employees as set forth in the Agreement.

20. Substitutions. Should the bidder wish to request any substitution for the materials, process, service, or equipment specified, the bidder shall be required to comply with Article 30 of the General Conditions.

21. Surety Qualifications for Bonds. Bidders shall ensure all surety companies have a minimum rating of "A-VIII," as rated by the current edition of Best's Key Rating Guide, published by A.M. Best Company, Oldwick, New Jersey 08858. Only California admitted surety insurers will be acceptable for the issuance of bonds. (Code of Civil Procedure Section 995.311) DISTRICT shall verify the status of the surety by one of the following ways: (1) printing out information from the website of the California Department of Insurance confirming the surety is an admitted surety insurer and attaching it to the bond, or (2) obtaining a certificate from the county clerk for the county in which the DISTRICT is located that confirms the surety is an admitted surety insurer and attaching it to the bond. Any admitted surety insurer who cannot satisfy the minimum rating specified above, but who satisfies the following requirements set forth in Code of Civil Procedure Section 995.660 shall be accepted and approved for the issuance of bonds:

(a) There must be on file in the office of the county clerk, for the county in which the DISTRICT is located, an unrevoked appointment, power of attorney, bylaws, or other instrument, duly certified by the proper authority and attested by the seal of the insurer authorizing the person who executed the bond to do so for and on behalf of the insurer within ten (10) calendar days of the insurer's receipt of a request to submit such document from the DISTRICT, and an original or certified copy of the document must be submitted to the DISTRICT.

(b) A certified copy of the certificate of authority of the insurer issued by the Insurance Commissioner must be submitted to the DISTRICT within ten (10) calendar days of the insurer's receipt of a request to submit such document from the DISTRICT.

(c) A certificate from the clerk of the county that the certificate of authority of the insurer has not been surrendered, revoked, cancelled, annulled, or suspended, and in the event it has, whether renewed authority has been granted must be submitted to DISTRICT within ten (10) calendar days of the insurer's receipt of a request to submit such document from the DISTRICT.

(d) Copies of the insurer's most recent annual statement and quarterly statement filed with the California Department of Insurance must be submitted to the DISTRICT within ten (10) calendar days of the insurer's receipt of a request to submit the statements.

22. Liquidated Damages. All work must be completed within the time limits set forth in the Project Documents. It is agreed that damages for the failure to complete the Project described herein within the time limits required are impossible to ascertain. Should the work not be completed within the specified time for completion, the successful bidder awarded the contract shall be liable for liquidated damages, payable to the DISTRICT, in an amount of **Five Hundred Dollars (\$500.00)** for each consecutive calendar day of delay in completion. Such damages shall be deducted from any payments due or to become due to the successful bidder. Government Code Section 53069.85, Civil Code Section 1671.

23. Drug-Free Workplace Certification. Pursuant to Government Code Sections 8350, et seq., the successful bidder will be required to execute a Drug-Free Workplace Certification upon execution of the Agreement. The bidder will be required to take positive measures outlined in the certification in order to ensure the presence of a drug-free workplace. Failure to abide with the conditions set forth in the Drug-Free Workplace Act could result in penalties including termination of the Agreement or suspension of payment thereunder.

24. Noncollusion Declaration. In accordance with the provisions of Section 7106 of the Public Contract Code, each bid must be accompanied by a Noncollusion Declaration.

25. Escrow Agreement. Public Contract Code Section 22300 permits the substitution of securities for any monies withheld by a public agency to ensure performance under a contract. At the request and expense of the successful bidder awarded the contract, securities equivalent to the amount withheld as retention shall be deposited with the DISTRICT, or with a state or federally chartered bank in California as the escrow agent, who shall then pay such monies to the successful bidder. The DISTRICT retains the sole discretion to approve the bank selected by the successful bidder to serve as escrow agent. Upon satisfactory completion of the contract, the securities shall be returned to the successful bidder. Securities eligible for investment shall include those listed in Government Code Section 16430 or bank or savings and loan certificates of deposit. The successful bidder shall be the beneficial owner of any securities substituted for monies withheld and shall receive any interest thereon.

In the alternative, under Section 22300, the successful bidder may request DISTRICT to make payment of earned retentions directly to the escrow agent at the expense of the successful bidder. Also at the successful bidder's expense, the successful bidder may direct investment of the payments into securities, and the successful bidder shall receive interest earned on such investment upon the same conditions as provided for securities deposited by successful bidder. Upon satisfactory completion of the contract, successful bidder shall receive from the escrow agent all securities, interest and payments received by escrow agent from DISTRICT pursuant to the terms of Section 22300.

The successful bidder who elects to receive interest on monies withheld in retention by the DISTRICT shall, at the request of any subcontractor performing more than five percent (5%) of the successful bidder's total bid, make that option available to the subcontractor regarding any monies withheld in retention by the successful bidder from the subcontractor. If the successful bidder elects to receive interest on any monies withheld in retention by the DISTRICT, then the subcontractor shall receive the identical rate of interest received by the successful bidder on any retention monies withheld from the subcontractor by the successful bidder, less any actual pro rata costs associated with administering and calculating that interest. In the event that the interest rate is a fluctuating rate, the rate for the subcontractor shall be determined by calculating the interest rate paid during the time that retentions were withheld from the subcontractor. If the successful bidder elects to substitute securities in lieu of retention, then, by mutual consent of the successful bidder and subcontractor, the subcontractor may substitute securities in exchange for the release of monies held in retention by the successful bidder. Public Contract Code Section 22300(d)(1).

The successful bidder wishing to utilize Public Contract Code Section 22300 and enter into an Escrow Agreement shall complete and execute the form Escrow Agreement included in the Project Documents and submit it to the DISTRICT.

26. Change Orders. All change order requests must be submitted in the form set forth in the Project Documents and pursuant to Article 59 of the General Conditions. The amount of allowable charges submitted pursuant to a change order shall be limited to the charges allowed under Article 59 of the General Conditions. Indirect, consequential and incidental costs, project

management costs, extended home office and field office overhead, administrative costs and profit and other charges not specifically authorized under Article 59 of the General Conditions will not be allowed.

27. Tobacco-Free Policy. The successful bidder shall agree to enforce a tobacco-free work site.

28. Criminal Records Check. The successful bidder will be required to comply with the applicable requirements of Education Code Section 45125.1 with respect to fingerprinting of employees and must complete the District's Criminal Records Check Certification.

29. Protest. Bidders may protest the recommended award, provided the protest is in writing, contains the bid number, is delivered to the address listed for submission of bid documents, and is submitted within five (5) calendar days of the losing of the bid deadline. Grounds for a protest is that the District failed to follow the selection procedures and adhere to requirements specified in the bid documents or any addenda or amendments; there has been a violation of conflict of interest as provided in California Government Code Section 87100 et. Seq. or violation of any State or Federal law. Protests will not be accepted on any other grounds. All protests will be handled by a panel comprised of District Staff. The District will consider only these specific issues addressed in the written protest. A written response will be directed to the protesting bidder within five (5) calendar days of the receipt of the protest, advising the decision with regard to the protest and the basis for the decision.

30. Labor Compliance Program. The awarded Contractor shall comply with the requirements of the State of California's Standard Specification Code Section 7-1.01A(4) "Labor Nondiscrimination" under this agreement.

31. Each Bidder shall comply with Senate Bill 854 ("SB854") including, but limited to, registration with California Department of Industrial Relations ("DIR"). The DIR's website is <http://www.dir.ca.gov>. Each contractor and subcontractor should carefully review the DIR website for all applicable requirements to be eligible to bid on this project and if needed should consult with an attorney. Copies of the wage rate determinations, entitled Prevailing Wage Scale, are available at the following website: [www.dir.ca.gov](http://www.dir.ca.gov). It shall be mandatory upon the successful bidder to whom the contract is awarded, and upon any subcontractor listed, to pay not less than the said specified rates to all workers employed by them for this bid

32. The number of executed copies of the Agreement will be required is **One (1)**.

33. The bidder shall comply with all Federal, State and Local required mechanical inspection and preventive maintenance schedules. The bidder shall keep and maintain all delivery vehicles in good operating and safe and clean condition. The District reserves the right to periodically inspect delivery vehicles while on District property. The District reserves the right to periodically inspect all maintenance records of vehicles used to service the District.

**BID FORM**

Name of Bidder: \_\_\_\_\_  
To: Irvine Unified School District, acting by and through its Governing Board, herein called the "DISTRICT."

1. The undersigned Bidder, having become familiarized with all the following documents including but not limited to the Notice Calling for Bids, Information for Bidders, Bid Form, Bid Form Pricing Sheet, Bid Security, Information Required of Bidder, all prequalification forms pursuant to Public Contract Code Section 20111.5, if any, Noncollusion Declaration, Workers' Compensation Certificate, Agreement, Drug-Free Workplace Certification, Criminal Records Check Certification, Change Order Forms, all insurance requirements, Guarantee forms, Contractor's Certificate Regarding Non-Asbestos Containing Materials, Disabled Veteran Business Enterprises Certification, if applicable, General Conditions and Supplemental Conditions, if any, Special Conditions, if any, specifications, scope of work, and all modifications, addenda and amendments, if any (hereinafter Project Documents), the local conditions affecting the performance of the work and the cost of the work at the place where the work is to be done, hereby proposes and agrees to be bound by all the terms and conditions of the Project Documents and agrees to perform, within the time stipulated, the work, including all of its component parts, and everything required to be performed, and to provide and furnish and pay for any and all of the labor, materials, tools, expendable equipment, and all applicable taxes, utility and transportation services necessary to perform the work and complete in a good workmanlike manner all of the work required in accordance with laws, codes, regulations, ordinances and any other legal requirements governing the work, in connection with the following:

**Bid No. 24/25-02MO, Unit Cost Pricing for Concrete**

all in strict conformity with the Project Documents, including Addenda Nos. \_\_\_\_\_, \_\_\_\_\_, \_\_\_\_\_, and \_\_\_\_\_, on file at the office of the DISTRICT for the sum of **(award for Base Bid will be the 'Total Bid Amount' from page 8 of the Bid Form & Bid Form Pricing Sheet)** \_\_\_\_\_ Dollars (\$\_\_\_\_\_).

Each individual bid term shall be determined from visiting the work site, reviewing the drawings and specifications and all portions of the Project Documents, and shall include all items necessary to complete the work, including the assumption of all obligations, duties, and responsibilities necessary to the successful completion of the Project, and the furnishing of all materials and equipment required to be incorporated in and form a permanent part of the work, and the furnishing of tools, equipment, supplies, transportation, facilities, labor, superintendence, and services required to perform and complete the work, all as per the requirements of the Project Documents, whether or not expressly listed or designated.

2. It is understood that the DISTRICT reserves the right to reject any or all bids or to waive any irregularities or informalities in any bids or in the bidding process. Bidder agrees that this bid shall remain open and not be withdrawn for the period specified in the Information for Bidders.

3. The initial term of the Agreement is February 1, 2025 through June 30, 2026. Term of the Agreement may be extended upon mutual consent of District and successful bidder(s) and the approval of the DISTRICT's Governing Board, for an additional three (3) one (1) year periods in accordance with provisions contained in the Education Code section 17596 (K-12). The maximum term of the Agreement is five (5) years.

4. The required bid security is attached.

6. It is understood and agreed that if written notice of the award of a contract is mailed, faxed, or delivered to the bidder, the bidder will execute and deliver to the DISTRICT the Agreement and will also furnish and deliver to the DISTRICT the certificates and endorsements of insurance, the Workers' Compensation Certificate, Drug-Free Work Place Certification, the Criminal Records Check Certification, Contractor's Certificate Regarding Non-Asbestos Containing Materials, District Rules and Regulations, Guarantee, and the Disabled Veteran Business Enterprises Certification, if applicable, within **five ( 5 )** working days of the notice of award of the contract, or as otherwise requested in writing by the DISTRICT. It is understood that should bidder fail or refuse to return these documents as required by the DISTRICT, the bid security shall be forfeited to the DISTRICT. The bidder further agrees that the work shall be commenced by the bidder, if awarded the contract, as per the date stated on the DISTRICT's Notice to Proceed and shall be completed by the bidder in the time specified by the DISTRICT.

7. Communications conveying notice of award of the contract, requests for additional information or other correspondence should be addressed to the bidder at the address stated below.

8. The name(s) of all persons interested in the bid as principals are as follows:

---

---

---

9. In submitting this bid, the bidder offers and agrees that if the bid is accepted, it will assign to DISTRICT all rights, title and interest in and to all causes of action it may have under Section 4 of the Clayton Act (15 U.S.C. Section 15) or under the Cartwright Act (Business & Professions Code Section 16700, et seq.) arising from purchases of goods, materials, or services by the bidder for sale to the DISTRICT pursuant to the bid. Such assignment shall be made and become effective at the time the DISTRICT tenders final payment under the contract. (Public Contract Code Section 7103.5; Government Code Section 4450, 4451 and 4552).

10. The undersigned hereby warrants that the bidder has an appropriate license, License No. \_\_\_\_\_, Class \_\_\_\_\_, at the time of the bid opening, that such license entitles bidder to provide the work, that such license will be in full force and effect throughout the duration of performance of this Project. Bidder shall be nonresponsive if the Bidder is not licensed as required by the DISTRICT at the time of the bid opening. Any and all subcontractors to be employed by the undersigned shall have appropriate licenses at the time of the bid opening.

11. The bidder hereby certifies that it is, and at all times during the performance of work hereunder shall be, in full compliance with the provisions of the Immigration Reform and



Control Act of 1986 ("IRCA") in the hiring of its employees, and the bidder shall indemnify, hold harmless and defend the DISTRICT against any and all actions, proceedings, penalties or claims arising out of the bidder's failure to comply strictly with the IRCA.

12. It is understood and agreed that if requested by the DISTRICT, the bidder shall furnish a notarized financial statement, references, and other information required by the DISTRICT sufficiently comprehensive to permit an appraisal of bidder's ability to perform the Project.

13. The undersigned hereby warrants that all work shall be completed within the specified time from the date specified in the Notice to Proceed issued by the District. Time is of the essence. The undersigned agrees that failure to complete the work within the time set forth herein will result in the imposition of liquidated damages for each consecutive calendar day of delay in the amount of Five Hundred Dollars (\$500.00). (Government Code Section 53069.85)

14. The required noncollusion declaration properly notarized is attached as required by Public Contract Code Section 7106. Bidder understands and agrees that failure to submit a completed and signed affidavit will render the bidder automatically nonresponsive.

15. It is understood and agreed that all change order requests must be submitted in the form set forth in the Project Documents and pursuant to Article 59 of the General Conditions. The amount of allowable charges submitted pursuant to a change order shall be limited to the charges allowed under Article 59 of the General Conditions. Indirect, consequential and incidental costs, project management costs, extended home office and field office overhead, administrative costs and profit and other charges not specifically authorized under Article 59 of the General Conditions will not be allowed.

16. The Information Required of Bidder form has been fully completed and is attached hereto.



## BID FORM PRICING SHEET

All pricing listed below must include labor, applicable delivery, installation, taxes and any miscellaneous costs. Bidders must complete all items, or the bid submitted may be declared non-responsive. Lowest bid shall be determined by sum of selected items. (See page 8)

<b>4" Thick Reinforced p.c.c. flatwork. Refer to Appendix C #301 for reinforcing and edge conditions.</b>		
250 SF to 2,500 SF	Square Foot	\$
2,501 SF to 5,000 SF	Square Foot	\$
5,001 SF to 7,500 SF	Square Foot	\$
7,501 SF to 10,000 SF	Square Foot	\$
<b>6" Thick Reinforced p.c.c. flatwork. Refer to Appendix C #301 for reinforcing and edge conditions.</b>		
250 SF to 2,500 SF	Square Foot	\$
2,501 SF to 5,000 SF	Square Foot	\$
5,001 SF to 7,500 SF	Square Foot	\$
7,501 SF to 10,000 SF	Square Foot	\$
<b>Reinforced p.c.c. curb with 6" face. Refer to Appendix C #302 for profile and reinforcing.</b>		
100 LF to 250 LF	Lineal Foot	\$
251 LF to 500 LF	Lineal Foot	\$
501 LF to 1,000 LF	Lineal Foot	\$
1,001 LF to 2,000 LF	Lineal Foot	\$
<b>Reinforced p.c.c. curb with 8" face. Refer to Appendix C #302 for profile and reinforcing.</b>		
100 LF to 250 LF	Lineal Foot	\$
251 LF to 500 LF	Lineal Foot	\$
501 LF to 1,000 LF	Lineal Foot	\$
1,001 LF to 2,000 LF	Lineal Foot	\$
<b>Reinforced p.c.c. curb and gutter with 6" curb face. Refer to Appendix C #303 for profile and reinforcing.</b>		
100 LF to 250 LF	Lineal Foot	\$
251 LF to 500 LF	Lineal Foot	\$
501 LF to 1,000 LF	Lineal Foot	\$
1,001 LF to 2,000 LF	Lineal Foot	\$
<b>Reinforced p.c.c. curb and gutter with 8" curb face. Refer to Appendix C #303 for profile and reinforcing.</b>		
100 LF to 250 LF	Lineal Foot	\$
251 LF to 500 LF	Lineal Foot	\$
501 LF to 1,000 LF	Lineal Foot	\$
1,001 LF to 2,000 LF	Lineal Foot	\$

<b>2'-0" wide reinforced p.c.c. vee gutter. Refer to Appendix C #304 for profile and reinforcing.</b>		
100 LF to 250 LF	Lineal Foot	\$
251 LF to 500 LF	Lineal Foot	\$
501 LF to 1,000 LF	Lineal Foot	\$
1,001 LF to 2,000 LF	Lineal Foot	\$
<b>3'-0" wide reinforced p.c.c. vee gutter. Refer to Appendix C #304 for profile and reinforcing.</b>		
100 LF to 250 LF	Lineal Foot	\$
251 LF to 500 LF	Lineal Foot	\$
501 LF to 1,000 LF	Lineal Foot	\$
1,001 LF to 2,000 LF	Lineal Foot	\$
<b>6" wide reinforced p.c.c. mow strip. Refer to Appendix C #305 for profile reinforcing.</b>		
100 LF to 250 LF	Lineal Foot	\$
251 LF to 500 LF	Lineal Foot	\$
501 LF to 1,000 LF	Lineal Foot	\$
1,001 LF to 2,000 LF	Lineal Foot	\$
<b>HC Access Improvement. Refer to Appendix C #310, #311, #312 for profile, reinforcing, etc.</b>		
HC Loading Ramp (#310)	Each	\$
HC Inlet Curb Ramp 6" curb face (#311)	Each	\$
HC Inlet Curb Ramp 8" curb face (#311)	Each	\$
HC Curb Ramp 6" curb face (#312)	Each	\$
HC Curb Ramp 8" curb face (#312)	Each	\$
<b>Expansion and Construction Joints. Refer to Appendix C #313 for expansion joint information.</b>		
Smooth Dowel and Sleeve (#313)	Each	\$
Manually Drill and Dowel with #3 bar at existing conc.	Each	\$
2 Part expansion joint filler/sealer (#313)	PLF	\$
<b>Concrete Light Pole Bases. Refer to Appendix C #314 for profile, reinforcing, etc.</b>		
0' to 15' Pole Height	Each	\$
15' to 20' Pole Height	Each	\$
20' to 25' Pole Height	Each	\$
25' to 30' Pole Height	Each	\$
<b>2'-0" High (Average) Concrete Planter Wall. Refer to Appendix C #315 for profile, reinforcing, accessories, etc.</b>		
20 LF to 50 LF	Lineal Foot	\$
51 LF to 200 LF	Lineal Foot	\$
201 LF to 400 LF	Lineal Foot	\$

<b>3'-0" High (Average) Concrete Planter Wall. Refer to Appendix C #315 for profile, reinforcing, accessories, etc.</b>		
20 LF to 50 LF	Lineal Foot	\$
51 LF to 200 LF	Lineal Foot	\$
201 LF to 400 LF	Lineal Foot	\$
<b>2'-0" High (Average) Concrete Planter Wall with sleeves for fencing or rails. Refer to Appendix C #316 for profile, reinforcing, accessories, etc.</b>		
20 LF to 50 LF	Lineal Foot	\$
51 LF to 200 LF	Lineal Foot	\$
201 LF to 400 LF	Lineal Foot	\$
<b>3'-0" High (Average) Concrete Planter Wall with sleeves for fencing or rails. Refer to Appendix C #316 for profile, reinforcing, accessories, etc.</b>		
20 LF to 50 LF	Lineal Foot	\$
51 LF to 200 LF	Lineal Foot	\$
201 LF to 400 LF	Lineal Foot	\$
<b>4" Base</b>		
500 SF to 3,000 SF	Square Foot	\$
3,001 SF to 6,000 SF	Square Foot	\$
6,001 SF to 12,000 SF	Square Foot	\$
<b>6" Base</b>		
500 SF to 3,000 SF	Square Foot	\$
3,001 SF to 6,000 SF	Square Foot	\$
6,001 SF to 12,000 SF	Square Foot	\$
<b>Removal of existing concrete up to 4" thick (un-reinforced).</b>		
500 SF to 1,000 SF	Square Foot	\$
1,001 SF to 3,000 SF	Square Foot	\$
3,001 SF to 6,000 SF	Square Foot	\$
6,001 SF to 12,000 SF	Square Foot	\$
<b>Removal of existing concrete up to 4" thick (Reinforced).</b>		
500 SF to 1,000 SF	Square Foot	\$
1,001 SF to 3,000 SF	Square Foot	\$
3,001 SF to 6,000 SF	Square Foot	\$
6,001 SF to 12,000 SF	Square Foot	\$
<b>Removal of existing asphalt up to 4" thick.</b>		
500 SF to 1,000 SF	Square Foot	\$
1,001 SF to 3,000 SF	Square Foot	\$
3,001 SF to 6,000 SF	Square Foot	\$
6,001 SF to 12,000 SF	Square Foot	\$

<b>Sawcutting</b>		
Concrete – under 200 LF	Lineal Foot	\$
Concrete – over 200 LF	Lineal Foot	\$
Asphalt – under 200 LF	Lineal Foot	\$
Asphalt – over 200 LF	Lineal Foot	\$
<b>Removal of Existing Sod</b>		
0 SF to 500 SF	Square Foot	\$
501 SF to 1,000 SF	Square Foot	\$
1,001 SF to 3,000 SF	Square Foot	\$
3,001 SF to 6,000 SF	Square Foot	\$
6,001 SF to 12,000 SF	Square Foot	\$
<b>Grading, Scarifying, Recompacting, etc.</b>		
Manual Grading	Square Foot	\$
Machine Fine Grading	Square Foot	\$
<b>Excavate and Export Native Soils.</b>		
0 CY to 6 CY	Cubic Yard	\$
6 CY to 20 CY	Cubic Yard	\$
20 CY to 100 CY	Cubic Yard	\$
100 CY to 200 CY	Cubic Yard	\$

<b>Award for base bid will be determined by:</b>		
4" Thick Reinforced p.c.c. flatwork	3,000 Square Feet	\$
Removal of existing concrete up to 4" thick (Reinforced)	3,500 Square Feet	\$
Removal of existing sod	2,900 Square Feet	\$
Excavate and export native soils	18 Cubic Yards	\$
Machine fine grading	1,500 Square Feet	\$
Manual grading	1,500 Square Feet	\$
<b>TOTAL BID AMOUNT</b>		<b>\$</b>

**ALL items in the Bid Form Pricing Sheet MUST be filled in.**

**Enter 'TOTAL BID AMOUNT' on page 1 of the Bid Form. All pages of the Bid Form & Bid Form Pricing Sheet MUST be filled in and returned with bid submittal.**

The undersigned hereby declares that all of the representations of this bid are made under penalty of perjury under the laws of the State of California.

**Individual** Name: \_\_\_\_\_  
Signed by: \_\_\_\_\_  
Print Name: \_\_\_\_\_  
Date: \_\_\_\_\_  
Business Address: \_\_\_\_\_  
\_\_\_\_\_  
Telephone: \_\_\_\_\_

\*\*\*\*\*

**Partnership** Name: \_\_\_\_\_  
Signed by: \_\_\_\_\_  
Print Name: \_\_\_\_\_  
Date: \_\_\_\_\_  
Business Address: \_\_\_\_\_  
\_\_\_\_\_  
Telephone: \_\_\_\_\_  
Other Partner(s): \_\_\_\_\_

\*\*\*\*\*

**Corporation** Name: \_\_\_\_\_  
(a \_\_\_\_\_ Corporation<sup>1</sup>)  
Business Address: \_\_\_\_\_  
\_\_\_\_\_  
Telephone: \_\_\_\_\_  
Signed by: \_\_\_\_\_, President, Date: \_\_\_\_\_  
Print Name: \_\_\_\_\_, President  
Signed by: \_\_\_\_\_, Secretary, Date: \_\_\_\_\_  
Print Name: \_\_\_\_\_, Secretary  
[Seal]

---

<sup>1</sup> A corporation awarded the contract shall furnish evidence of its corporate existence and evidence that the officer signing the Agreement and bonds is duly authorized to do so.

Joint Venturer

Name: \_\_\_\_\_

Signed by: \_\_\_\_\_, Joint Venturer

Print Name: \_\_\_\_\_

Date: \_\_\_\_\_

Business Address: \_\_\_\_\_  
\_\_\_\_\_

Telephone: \_\_\_\_\_

Other Parties to  
Joint Venture:

***If an individual:*** \_\_\_\_\_  
(Name)

Signed by: \_\_\_\_\_

Print Name: \_\_\_\_\_

Date: \_\_\_\_\_

Doing Business as: \_\_\_\_\_;

Business Address: \_\_\_\_\_  
\_\_\_\_\_

Telephone: \_\_\_\_\_

***If a Partnership:*** \_\_\_\_\_  
(Name)

Signed by: \_\_\_\_\_, Partner

Print Name: \_\_\_\_\_

Date: \_\_\_\_\_

Business Address: \_\_\_\_\_  
\_\_\_\_\_

Telephone: \_\_\_\_\_

***If a Corporation:*** \_\_\_\_\_  
(a \_\_\_\_\_ Corporation)

Signed By: \_\_\_\_\_ Date: \_\_\_\_\_

Print Name: \_\_\_\_\_

Title: \_\_\_\_\_

Date: \_\_\_\_\_

Business Address: \_\_\_\_\_  
\_\_\_\_\_

Telephone: \_\_\_\_\_



Bid Bond No.: \_\_\_\_\_

**BID BOND**

KNOW ALL PERSONS BY THESE PRESENT, that we \_\_\_\_\_, as Principal, and \_\_\_\_\_ as Surety, a California admitted surety insurer, are held and firmly bound unto the Irvine Unified School DISTRICT, hereinafter called the DISTRICT, in the sum of **TEN PERCENT (10%) OF THE 'TOTAL BID AMOUNT' FROM PAGE 1 OF THE BID FORM** for the work described below for the payment of which sum in lawful money of the United States, well and truly to be made, we jointly and severally bind ourselves, our heirs, executors, administrators, successors and assigns.

The condition of this obligation is such that whereas the Principal has submitted the accompanying bid dated \_\_\_\_\_, 20\_\_\_, for:

**Bid No. 24/25-02MO, Unit Cost Pricing for Concrete.**

NOW, THEREFORE, if the Principal shall not withdraw said bid within the period specified therein after the opening of the same, or, if no period be specified, within sixty (60) days after said opening; and if the Principal is awarded the contract, and shall within the period specified therefore, or, if no period be specified, within **five (5)** working days after the notice of award of the contract, or as otherwise requested in writing by the DISTRICT, enter into a written contract with the DISTRICT, in accordance with the bid as accepted and give bonds with good and sufficient surety or sureties, as may be required for the faithful performance and proper fulfillment of such contract and for the payment for labor and materials used for the performance of the contract, furnish certificates and endorsements evidencing the required insurance is in effect and furnish and deliver to the DISTRICT the Workers' Compensation Certificate, Drug-Free Work Place Certification, the Criminal Records Check Certification, Contractor's Certificate Regarding Non-Asbestos Containing Materials, and the Disabled Veteran Business Enterprises Certification, if applicable, then the above obligation shall be void and of no effect, otherwise the bond amount shall be forfeited to the DISTRICT.

Surety, for value received, hereby stipulates and agrees that no change, extension of time, alteration or addition to the terms of the contract or the call for bids, or to the work to be performed thereunder, or the specifications accompanying the same, shall in any way affect its obligation under this bond, and it does hereby waive notice of any such change, extension of time, alteration or addition to the terms of said contract or the call for bids, or to the work, or to the specifications.

In the event suit is brought upon this bond by the DISTRICT and judgment is recovered, the Surety shall pay all costs incurred by the DISTRICT in such suit, including reasonable attorney's fees to be fixed by the court.

IN WITNESS HEREOF, the parties have executed this bond under their several seals this day of \_\_\_\_, 20\_\_, the name and corporate seal of each corporate party being hereto affixed and duly signed by its undersigned authorized representative.

(Corporate Seal of  
Principal, if  
Corporation)

\_\_\_\_\_  
Principal (Proper Name of Bidder)

By: \_\_\_\_\_  
Signature

\_\_\_\_\_  
Print Name

\_\_\_\_\_  
Title

(Corporate Seal  
of Surety)

\_\_\_\_\_  
Surety

(Attach Attorney-in-Fact Certificate  
and Required Acknowledgements)

By: \_\_\_\_\_  
Signature

\_\_\_\_\_  
Print Name

\_\_\_\_\_  
Title

\_\_\_\_\_  
Address

\_\_\_\_\_  
Telephone No.

\_\_\_\_\_  
Facsimile No.

**INFORMATION REQUIRED OF BIDDER**

The Bidder shall furnish all the following information. Bidder shall carefully read and answer all questions to ensure completeness and accuracy. Failure to comply with this requirement may cause rejection of the bid. Additional sheets may be attached if necessary. "You" or "your" as used herein refers to the bidder and any of its owners, officers, directors, shareholders, principals, responsible managing officer (RMO) or responsible managing employee (RME). DISTRICT has discretion to request additional information depending on the Project.

(1) Bidder name and address (Post Office Box Number not sufficient):

\_\_\_\_\_  
\_\_\_\_\_  
\_\_\_\_\_  
\_\_\_\_\_

(2) Telephone: \_\_\_\_\_ Fax No.: \_\_\_\_\_  
Electronic Mail: \_\_\_\_\_

(3) Individual \_\_\_\_\_ Partnership \_\_\_\_\_ Corporation \_\_\_\_\_ Joint Venture \_\_\_\_\_ (check one)

(4) Bidder's License No. \_\_\_\_\_ Class: \_\_\_\_\_  
License Expiration Date \_\_\_\_\_  
Name of License holder \_\_\_\_\_

(5) Have you ever been licensed under a different name or different license number?  
Yes \_\_\_ No \_\_\_ If "Yes," give name and license number.

\_\_\_\_\_  
\_\_\_\_\_  
\_\_\_\_\_.

(6) Names and titles of all your owners, officers, principals, responsible managing officers and responsible managing employees:

Name	Title
_____	_____
_____	_____
_____	_____

(7) Number of years as a contractor in this type of construction work: \_\_\_\_\_  
\_\_\_\_\_

(8) Person who inspected work site:

Name and Title: \_\_\_\_\_

Date of Inspection: \_\_\_\_\_

(9) How many years experience have you had in school construction work?

(a) as a general contractor? \_\_\_\_\_

(b) as a subcontractor? \_\_\_\_\_

(10) How many years experience have you had in public construction work?

(a) as a general contractor? \_\_\_\_\_

(b) as a subcontractor? \_\_\_\_\_

(11) Have you ever been terminated from a school or any public construction project prior to the completion of the project? Yes \_\_\_ No \_\_\_ If the answer is "Yes," give dates, names and addresses of school/public agency and details. \_\_\_\_\_

\_\_\_\_\_  
\_\_\_\_\_  
\_\_\_\_\_  
\_\_\_\_\_

(12) Have you ever been barred from bidding on any school or public construction project? Yes \_\_\_ No \_\_\_ If the answer is "Yes," give dates, names and addresses of school/public agency and details. \_\_\_\_\_

\_\_\_\_\_  
\_\_\_\_\_  
\_\_\_\_\_  
\_\_\_\_\_

(13) Have you ever defaulted on any school or public construction project that resulted in a claim to a surety? Yes \_\_\_ No \_\_\_ If the answer is "Yes," give dates, names and addresses of school/public agency and details. \_\_\_\_\_

\_\_\_\_\_  
\_\_\_\_\_  
\_\_\_\_\_  
\_\_\_\_\_

(14) Have you been assessed damages (i.e., liquidated damages) for any public construction project in the past ten (10) years? Yes \_\_\_ No \_\_\_ If the answer is “Yes,” give dates, names, and addresses of public agency and details. \_\_\_\_\_

\_\_\_\_\_

\_\_\_\_\_

\_\_\_\_\_

(15) Have you ever brought any claim(s) against a public agency? Yes \_\_\_ No \_\_\_ If the answer is “Yes,” please explain in detail name of public agency, nature of the claim and outcome. \_\_\_\_\_

\_\_\_\_\_

\_\_\_\_\_

(16) Have you ever failed to complete a school or public construction project in the last ten (10) years? Yes \_\_\_ No \_\_\_ If the answer is “Yes,” provide name of public agency and details. \_\_\_\_\_

\_\_\_\_\_

\_\_\_\_\_

(17) Have you been in litigation or arbitration or dispute of any kind on a question or questions relating to a public construction project during the past ten (10) years? Yes \_\_\_ No \_\_\_ If the answer is “Yes,” provide name of public agency and details. \_\_\_\_\_

\_\_\_\_\_

\_\_\_\_\_

(18) List the names, addresses and telephone numbers of three Architects or Engineers whose jobs you have worked on in the past five (5) years.

<u>Name</u>	<u>Address</u>	<u>Telephone</u>
_____	_____	( ) _____
_____	_____	( ) _____
_____	_____	( ) _____

(19) Do you now or have you ever had any direct or indirect business, financial or other connection with any officer, employee or consultant of the DISTRICT or Architect?  
Yes \_\_\_ No \_\_\_ If so, please elaborate.

\_\_\_\_\_  
\_\_\_\_\_  
\_\_\_\_\_

(20) List at least five (5) of your most recent school construction projects.

(1) \_\_\_\_\_  
(2) \_\_\_\_\_  
(3) \_\_\_\_\_  
(4) \_\_\_\_\_  
(5) \_\_\_\_\_

(21) Are you currently under contract for another project? Yes \_\_\_ No \_\_\_ If the answer is “Yes,” please provide the following information:

(a) Project Number 1:

Name of Project: \_\_\_\_\_

Detailed Description: \_\_\_\_\_  
\_\_\_\_\_

Name of Project Owner: \_\_\_\_\_

Contract Amount: \_\_\_\_\_

Completion Date: \_\_\_\_\_

(b) Project Number 2:

Name of Project: \_\_\_\_\_

Detailed Description: \_\_\_\_\_  
\_\_\_\_\_

Name of Project Owner: \_\_\_\_\_

Contract Amount: \_\_\_\_\_

Completion Date: \_\_\_\_\_

(c) Project Number 3:

Name of Project: \_\_\_\_\_

Detailed Description: \_\_\_\_\_

Name of Project Owner: \_\_\_\_\_

Contract Amount: \_\_\_\_\_

Completion Date: \_\_\_\_\_

(d) Project Number 4:

Name of Project: \_\_\_\_\_

Detailed Description: \_\_\_\_\_

Name of Project Owner: \_\_\_\_\_

Contract Amount: \_\_\_\_\_

Completion Date: \_\_\_\_\_

(e) Project Number 5:

Name of Project: \_\_\_\_\_

Detailed Description: \_\_\_\_\_

Name of Project Owner: \_\_\_\_\_

Contract Amount: \_\_\_\_\_

Completion Date: \_\_\_\_\_

(22) Are there projects not listed above that will be undertaken during the duration of DISTRICT's Project? Yes \_\_\_\_\_ No \_\_\_\_\_ If the answer is "Yes," please provide the following information:

(a) Project Number 1:

Name of Project: \_\_\_\_\_

Detailed Description: \_\_\_\_\_

Name of Project Owner: \_\_\_\_\_

Contract Amount: \_\_\_\_\_

Completion Date: \_\_\_\_\_



(b) Project Number 2:

Name of Project: \_\_\_\_\_

Detailed Description: \_\_\_\_\_

\_\_\_\_\_  
Name of Project Owner: \_\_\_\_\_

Contract Amount: \_\_\_\_\_

Completion Date: \_\_\_\_\_

(c) Project Number 3:

Name of Project: \_\_\_\_\_

Detailed Description: \_\_\_\_\_

\_\_\_\_\_  
Name of Project Owner: \_\_\_\_\_

Contract Amount: \_\_\_\_\_

Completion Date: \_\_\_\_\_

(d) Project Number 4:

Name of Project: \_\_\_\_\_

Detailed Description: \_\_\_\_\_

\_\_\_\_\_  
Name of Project Owner: \_\_\_\_\_

Contract Amount: \_\_\_\_\_

Completion Date: \_\_\_\_\_

(e) Project Number 5:

Name of Project: \_\_\_\_\_

Detailed Description: \_\_\_\_\_

\_\_\_\_\_  
Name of Project Owner: \_\_\_\_\_

Contract Amount: \_\_\_\_\_

Completion Date: \_\_\_\_\_

(23) Additional information required: \_\_\_\_\_  
\_\_\_\_\_  
\_\_\_\_\_  
\_\_\_\_\_

(24) List of References - Public construction projects of similar nature in a school/community college/university within the last five (5) years. DISTRICT has discretion to require more than five (5) references.

1. Name: \_\_\_\_\_  
Address and Telephone: \_\_\_\_\_  
\_\_\_\_\_  
Contact Person: \_\_\_\_\_  
Description of Project: \_\_\_\_\_  
Dates of commencement and completion of Project: \_\_\_\_\_  
\_\_\_\_\_  
Contract Amount: \_\_\_\_\_  
Architect: \_\_\_\_\_  
Architect's Address and Telephone: \_\_\_\_\_  
\_\_\_\_\_  
DSA or public agency inspector: \_\_\_\_\_  
Address and Telephone: \_\_\_\_\_  
\_\_\_\_\_

2. Name: \_\_\_\_\_  
Address and Telephone: \_\_\_\_\_  
\_\_\_\_\_  
Contact Person: \_\_\_\_\_  
Description of Project: \_\_\_\_\_  
Dates of commencement and completion of Project: \_\_\_\_\_  
\_\_\_\_\_  
Contract Amount: \_\_\_\_\_  
Architect: \_\_\_\_\_  
Architect's Address and Telephone: \_\_\_\_\_  
\_\_\_\_\_

DSA or public agency inspector: \_\_\_\_\_

Address and Telephone: \_\_\_\_\_

\_\_\_\_\_

3. Name: \_\_\_\_\_

Address and Telephone: \_\_\_\_\_

\_\_\_\_\_

Contact Person: \_\_\_\_\_

Description of Project: \_\_\_\_\_

Dates of commencement and completion of Project: \_\_\_\_\_

\_\_\_\_\_

Contract Amount: \_\_\_\_\_

Architect: \_\_\_\_\_

Architect's Address and Telephone: \_\_\_\_\_

\_\_\_\_\_

DSA or public agency inspector: \_\_\_\_\_

Address and Telephone: \_\_\_\_\_

\_\_\_\_\_

4. Name: \_\_\_\_\_

Address and Telephone: \_\_\_\_\_

\_\_\_\_\_

Contact Person: \_\_\_\_\_

Description of Project: \_\_\_\_\_

Dates of commencement and completion of Project: \_\_\_\_\_

\_\_\_\_\_

Contract Amount: \_\_\_\_\_

Architect: \_\_\_\_\_

Architect's Address and Telephone: \_\_\_\_\_

\_\_\_\_\_

DSA or public agency inspector: \_\_\_\_\_

Address and Telephone: \_\_\_\_\_

\_\_\_\_\_

5. Name: \_\_\_\_\_  
Address and Telephone: \_\_\_\_\_  
\_\_\_\_\_  
Contact Person: \_\_\_\_\_  
Description of Project: \_\_\_\_\_  
Dates of commencement and completion of Project: \_\_\_\_\_  
\_\_\_\_\_  
Contract Amount: \_\_\_\_\_  
Architect: \_\_\_\_\_  
Architect's Address and Telephone: \_\_\_\_\_  
\_\_\_\_\_  
DSA or public agency inspector: \_\_\_\_\_  
Address and Telephone: \_\_\_\_\_  
\_\_\_\_\_

**I certify and declare under penalty of perjury under the laws of the State of California that the foregoing responses to the Information Required of Bidder are true and correct.**

\_\_\_\_\_  
Signature

\_\_\_\_\_  
Print Name

\_\_\_\_\_  
Title

\_\_\_\_\_  
Date

Note: DISTRICT may wish to expand the scope of the “Information Required of Bidder” form and include additional questions.

## DESIGNATION OF SUBCONTRACTORS

In compliance with the Subletting and Subcontracting Fair Practices Act (Public Contract Code Section 4100 et. seq.) and any amendments thereof, each bidder shall set forth below: (a) the name and the location of the place of business of each subcontractor who will perform work or labor or render service to the bidder (prime contractor) in or about the construction of the work or improvement to be performed under this contract or a subcontractor licensed by the State of California who, under subcontract to the bidder (prime contractor), specially fabricates and installs a portion of the work or improvement according to detailed drawings contained in the plans and specifications in an amount in excess of one-half of one percent of the bidder's (prime contractor's) total bid and (b) the portion of the work which will be done by each subcontractor. The bidder (prime contractor) shall list only one subcontractor for each such portion as is defined by the bidder (prime contractor) in this bid.

**If a bidder (prime contractor) fails to specify a subcontractor or if a bidder (prime contractor) specifies more than one subcontractor for the same portion of work to be performed under the contract in excess of one-half of one percent of the bidder's (prime contractor's) total bid, bidder shall be deemed to have agreed that bidder is fully qualified to perform that portion, and that bidder alone shall perform that portion. Violation of this requirement (including the procurement of a subcontractor for the Project if no subcontractor is specified) can result in the DISTRICT invoking the remedies of Public Contract Code Sections 4110 and 4111.**

No bidder (prime contractor) whose bid is accepted shall (a) substitute any subcontractor, (b) permit any subcontractor to be voluntarily assigned or transferred or allow it to be performed by any one other than the original subcontractor listed in the original bid, or (c) sublet or subcontract any portion of the work in excess of one-half of one percent of the bidder's (prime contractor's) total bid as to which the original bid did not designate a subcontractor, except as authorized in the Subletting and Subcontracting Fair Practices Act. Subletting or subcontracting of any portion of the work in excess of one-half of one percent of the bidder's (prime contractor's) total bid as to which no subcontractor was designated in the original bid shall only be permitted in cases of public emergency or necessity, only after a finding reduced to writing as a public record of the DISTRICT awarding this contract setting forth the facts constituting the emergency or necessity.

Type of trade, labor, or service	Name & License No. of Subcontractor License Expiration Date (Indicate if a Disabled Veteran Business Enterprise)	Complete Address (Name of City Not Sufficient) and Telephone No.	DIR Registration No.

Bidder agrees that within twenty-four (24) hours of the bid opening, Bidder shall provide the DISTRICT with the license number (if applicable), expiration date of license, complete address and telephone numbers of each listed subcontractor if such information is not available at the time of the bid opening.

Dated: \_\_\_\_\_

\_\_\_\_\_  
Name of Bidder

By: \_\_\_\_\_  
(Signature of Bidder)

Print Name: \_\_\_\_\_

Address: \_\_\_\_\_

\_\_\_\_\_

\_\_\_\_\_

Telephone: \_\_\_\_\_

**NONCOLLUSION DECLARATION TO BE EXECUTED BY**  
**BIDDER AND SUBMITTED WITH BID**  
(Public Contract Cod Section 7106)

The undersigned declares:

I am the \_\_\_\_\_ [Title] of \_\_\_\_\_ [Name of Company], the party making the foregoing bid.

The bid is not made in the interest of, or on behalf of, any undisclosed person, partnership, company, association, organization, or corporation. The bid is genuine and not collusive or sham. The bidder has not directly or indirectly induced or solicited any other bidder to put in a false or sham bid. The bidder has not directly or indirectly colluded, conspired, connived, or agreed with any bidder or anyone else to put in a sham bid, or to refrain from bidding. The bidder has not in any manner, directly or indirectly, sought by agreement, communication, or conference with anyone to fix the bid price of the bidder or any other bidder, or to fix any overhead, profit, or cost element of the bid price, or of that of any other bidder. All statements contained in the bid are true. The bidder has not, directly or indirectly, submitted his or her bid price or any breakdown thereof, or the contents thereof, or divulged information or data relative thereto, to any corporation, partnership, company, association, organization, bid depository, or to any member or agent thereof, to effectuate a collusive or sham bid, and has not paid, and will not pay, any person or entity for such purpose.

Any person executing this declaration on behalf of a bidder that is a corporation, partnership, joint venture, limited liability company, limited liability partnership, or any other entity, hereby represents that he or she has full power to execute, and does execute, this declaration on behalf of the bidder.

I declare under penalty of perjury under the laws of the State of California that the foregoing is true and correct and that this declaration is executed on \_\_\_\_\_ [Date], at \_\_\_\_\_ [City], \_\_\_\_\_ [State].

\_\_\_\_\_  
Signature

\_\_\_\_\_  
Print Name



**SAMPLE AGREEMENT**

THIS AGREEMENT, dated the \_\_\_ day of \_\_\_\_\_, 2024, in the County of Orange, State of California, is by and between **Irvine Unified School District**, (hereinafter referred to as "DISTRICT"), and \_\_\_\_\_, (hereinafter referred to as "CONTRACTOR").

The DISTRICT and the CONTRACTOR, for the consideration stated herein, agree as follows:

1. CONTRACTOR agrees to complete the Project known as **Bid No. 24/25-02MO, Unit Cost Pricing for Concrete** from \_\_\_\_\_ through \_\_\_\_\_ according to all the terms and conditions set forth in the Project Documents, including but not limited to the Notice Calling For Bids, Information for Bidders, Bid Form, Bid Form Pricing Sheet, Bid Security, Bid Bond, Designation of Subcontractors, Information Required of Bidder, all prequalification forms submitted pursuant to Public Contract Code Section 20111.5, if any, Noncollusion Declaration, Payment Bond, Faithful Performance Bond, Tobacco Use Policy, Workers' Compensation Certificate, Drug-Free Workplace Certification, Contractor's Certificate Regarding Non-Asbestos Containing Materials, Criminal Records Check Certification, District Rules and Regulations, Guarantee, Escrow Agreement, if applicable, Extract of Public Works Contract Award, Disabled Veteran Business Enterprises Certification, if applicable, Change Orders, Shop Drawing Transmittals, Insurance Certificates and Endorsements, W9, General Conditions, Specifications, Drawings, if any, Supplemental Conditions, if any, Special Conditions, if any, and any and all modifications, addenda and amendments thereto by this reference incorporated herein. The Project Documents are complementary, and what is called for by any one shall be as binding as if called for by all.

2. CONTRACTOR shall perform within the time set forth in Paragraph 4 of this Agreement everything required to be performed, and shall provide, furnish and pay for all the labor, materials, necessary tools, expendable equipment, and all taxes, utility and transportation services required for construction of the Project. All of said work shall be performed and completed in a good workmanlike manner in strict accordance with the drawings, specifications and all provisions of this Agreement as hereinabove defined and in accordance with applicable laws, codes, regulations, ordinances and any other legal requirements governing the Project. The CONTRACTOR shall be liable to the DISTRICT for any damages arising as a result of a failure to fully comply with this obligation, and the CONTRACTOR shall not be excused with respect to any failure to so comply by any act or omission of the Architect, Engineer, Inspector, Division of State Architect, or representative of any of them, unless such act or omission actually prevents the CONTRACTOR from fully complying with the requirements of the Project Documents, and unless the CONTRACTOR protests at the time of such alleged prevention that the act or omission is preventing the CONTRACTOR from fully complying with the Project Documents. Such protest shall not be effective unless reduced to writing and filed with the DISTRICT within three (3) working days of the date of occurrence of the act or omission preventing the CONTRACTOR from fully complying with the Project Documents.

3. DISTRICT shall pay to the CONTRACTOR, as full consideration for the faithful performance of this Agreement, subject to any additions or deductions as provided in the Project Documents, the sum NOT TO EXCEED \_\_\_\_\_, purchase orders to be processed as work is scheduled throughout the year with each requiring bonding and insurance per the contract.

4. The initial term of the Agreement is February 1, 2025 through June 30, 2026. Term of the Agreement may be extended upon mutual consent of District and successful bidder(s) and the approval of the DISTRICT's Governing Board, for an additional three (3) one (1) year periods in accordance with provisions contained in the Education Code section 17596 (K-12). The maximum term of the Agreement is five (5) years.

5. The work shall be commenced as specified. The DISTRICT reserves the right in its sole discretion to utilize other concrete contractors for work required by the DISTRICT.

6. **Time is of the essence.** If the work is not completed in accordance with Paragraph 4 above, it is understood that the DISTRICT will suffer damage. It being impractical and infeasible to determine the amount of actual damage, in accordance with Government Code Section 53069.85, it is agreed that CONTRACTOR shall pay to DISTRICT as fixed and liquidated damages, and not as a penalty, the sum of Five hundred Dollars (\$ 500.00 ) for each calendar day of delay until work is completed and accepted. Time extensions may be granted by the DISTRICT as provided in Article 63 of the General Conditions. Liquidated damages shall be imposed as set forth in Article 63 of the General Conditions.

7. Termination for Cause or Nonappropriation. In the event CONTRACTOR defaults in the performance of the Agreement as set forth in General Conditions Article 13(a) or if there is a nonappropriation of funds or insufficient funds as set forth in General Conditions Article 13(d), then this Agreement shall terminate or be suspended as set forth in General Conditions Article 13.

Termination for Convenience. DISTRICT has discretion to terminate this Agreement at any time and require CONTRACTOR to cease all work on the Project by providing CONTRACTOR written notice of termination specifying the desired date of termination. Upon receipt of written notice from DISTRICT of such termination for DISTRICT's convenience, CONTRACTOR shall:

- (i) Cease operations as directed by DISTRICT in the notice;
- (ii) Take any actions necessary, or that DISTRICT may direct, for the protection and preservation of the work; and
- (iii) Not terminate any insurance provisions required by the Project Documents.

In case of such termination for DISTRICT's convenience, CONTRACTOR shall be entitled to receive payment from DISTRICT for work satisfactorily executed and for proven loss with respect to materials, equipment, and tools, including overhead and profit for that portion of

the work completed. In the case of Termination for Convenience, DISTRICT shall have the right to accept assignment of subcontractors. The foregoing provisions are in addition to and not in limitation of any other rights or remedies available to the DISTRICT.

8. Hold Harmless and Indemnification. To the fullest extent permitted by law, the CONTRACTOR, at the CONTRACTOR's sole cost and expense, agrees to fully defend, indemnify and hold harmless, the DISTRICT, including but not limited to any of its governing board members, officers, employees and agents, from and against any and all claims, actions, demands, costs, judgments, liens, penalties, liabilities, damages, losses, anticipated losses of revenues, and expenses, including any fees of accountants, attorneys or other professionals, arising out of, in connection with, resulting from or related to, or claimed to be arising out of, in connection with, resulting from or related to any act or omission by the CONTRACTOR or any of its officers, agents, employees, subcontractors, sub-subcontractors, any person performing any of the work pursuant to a direct or indirect contract with the CONTRACTOR or individual entities comprising the CONTRACTOR, in connection with or relating to, or claimed to be in connection with or relating to the work, this Agreement, or the Project, including but not limited to any costs or liabilities arising out of or in connection with:

- (a) failure to comply with any applicable law, statute, code, ordinance, regulation, permit or orders;
- (b) any misrepresentation, misstatement or omission with respect to any statement made in the Project Documents or any document furnished by the CONTRACTOR in connection therewith;
- (c) any breach of duty, obligation or requirement under the Project Documents;
- (d) any failure to coordinate the work of other contractors;
- (e) any failure to provide notice to any party as required under the Project Documents;
- (f) any failure to act in such a manner as to protect the DISTRICT and the Project from loss, cost, expense or liability; or
- (g) any failure to protect the property of any utility company or property owner.

This indemnity shall survive termination of the contract or final payment thereunder. This indemnity is in addition to any other rights or remedies which the DISTRICT may have under the law or under the Project Documents. In the event of any claim or demand made against any party which is entitled to be indemnified hereunder, the DISTRICT may in its sole discretion reserve, retain or apply any monies due to the CONTRACTOR under the Project Documents for the purpose of resolving such claims; provided, however, that the DISTRICT may release such funds if the CONTRACTOR provides the DISTRICT with reasonable assurance of protection of the DISTRICT's interests. The DISTRICT shall in its sole discretion determine whether such assurances are reasonable.

9. CONTRACTOR shall take out, prior to commencing the work, and maintain, during the life of this Agreement, and shall require all subcontractors, if any, whether primary or secondary, to take out and maintain the insurance coverages set forth below and in Articles 16, 17,

18 and 19 of the General Conditions. CONTRACTOR agrees to provide all evidences of coverage required by DISTRICT including certificates of insurance and endorsements.

a. CONTRACTOR shall, at CONTRACTOR's sole cost and expense, maintain in full force and effect the following insurance coverages from a California licensed insurer with an A, VIII, or better rating from A.M. Best or an approved self-insurance program, sufficient to cover any claims, damages, liabilities, costs and expenses (including attorney fees) arising out of or in connection with CONTRACTOR's fulfillment of the obligations under this AGREEMENT:

(i) Comprehensive General Liability Insurance, including bodily injury, property damage and contractual liability with minimum limits set by the DISTRICT. The policy may not contain an exclusion for sexual molestation or abuse coverage, may be waived by the DISTRICT.

(1) General Aggregate	\$2,000,000
(2) Each Occurrence	\$1,000,000
(3) Products/Completed Operations	\$1,000,000
(4) Personal and Advertising Injury	\$1,000,000
(5) Damage to Rented Premises	\$50,000
(6) Medical Expense (any one person)	\$5,000

(ii) Umbrella (excess) liability insurance coverage with a limit of \$3,000,000, unless waived by the DISTRICT. The policy may not contain an exclusion for sexual molestation or abuse coverage, may be waived by the DISTRICT.

(iii) Business Automobile Liability Insurance for owned, scheduled, non-owned, or hired automobiles with a combined single limit not less than \$1,000,000 per occurrence. (Required only if the CONTRACTOR drives on behalf of the DISTRICT in the course of performing Services.)

(iv) Professional Liability Insurance with a limit of \$1,000,000 per occurrence, unless waived by the DISTRICT and if applicable.

(v) Workers' Compensation and Employers Liability Insurance in a form and amount covering CONTRACTOR's full liability under the California Workers' Compensation Insurance and Safety Act and in accordance with applicable state and federal laws. The policy shall be endorsed with the insurer's waiver of rights of subrogation against the DISTRICT.

It should be expressly understood, however, that the coverage and limits referred to under a., b., c., and d. above shall not in any way limit the liability of the CONTRACTOR.

b. No later than five (5) days from execution of this AGREEMENT by the DISTRICT and CONTRACTOR, and prior to commencing the Services under this

AGREEMENT, CONTRACTOR shall provide DISTRICT with certificates of insurance evidencing all coverages and endorsements required hereunder.

CONTRACTOR shall provide prior written notice to the DISTRICT thirty (30) days in advance of any non-renewal, cancellation, or modification of the required insurance. The certificates of insurance providing the coverages referred to in clauses (i) and (ii) above shall name DISTRICT, its Governing Board, officers, and employees, as additional insureds with appropriate endorsements. In addition, the certificates of insurance shall include a provision stating "Such insurance as is afforded by this policy shall be primary, and any insurance carried by DISTRICT shall be excess and noncontributory." Failure to maintain the above mentioned insurance coverages shall be cause for termination of this AGREEMENT

Insurance Covering Special Hazards: The following special hazards shall be covered by rider or riders to above-mentioned public liability insurance or property damage insurance policy or policies of insurance, or by special policies of insurance in amounts as follows:

Automotive and truck where operated in amounts as above

Material hoist where used in amounts as above

10. Public Contract Code Section 22300 permits the substitution of securities for any retention monies withheld by the DISTRICT to ensure performance under this Agreement. At the request and expense of the CONTRACTOR, securities equivalent to the monies withheld shall be deposited with the DISTRICT, or with a state or federally chartered bank in California as the escrow agent, who shall then pay such monies to the CONTRACTOR. The DISTRICT retains the sole discretion to approve the bank selected by the CONTRACTOR to serve as escrow agent. Upon satisfactory completion of the Agreement, the securities shall be returned to the CONTRACTOR. Securities eligible for investment shall include those listed in Government Code Section 16430 or bank or savings and loan certificates of deposit. The CONTRACTOR shall be the beneficial owner of any securities substituted for monies withheld and shall receive any interest thereon.

In the alternative, under Section 22300, the CONTRACTOR may request DISTRICT to make payment of earned retention monies directly to the escrow agent at the expense of the CONTRACTOR. Also at the CONTRACTOR's expense, the CONTRACTOR may direct investment of the payments into securities, and the CONTRACTOR shall receive interest earned on such investment upon the same conditions as provided for securities deposited by CONTRACTOR. Upon satisfactory completion of the Agreement, CONTRACTOR shall receive from the escrow agent all securities, interest and payments received by escrow agent from DISTRICT pursuant to the terms of Section 22300.

11. If CONTRACTOR is a corporation, the undersigned hereby represents and warrants that the corporation is duly incorporated and in good standing in the State of California, and that \_\_\_\_\_, whose title is \_\_\_\_\_, is authorized to act for and bind the corporation.

12. Each and every provision of law and clause required by law to be inserted in this Agreement shall be deemed to be inserted herein and the Agreement shall be read and enforced as though it were included herein, and if through mistake or otherwise any such provision is not inserted, or is not currently inserted, then upon application of either party the Agreement shall forthwith be physically amended to make such insertion or correction.

13. This Agreement constitutes the entire agreement of the parties. No other agreements, oral or written, pertaining to the work to be performed, exists between the parties. This Agreement can be modified only by an amendment in writing, signed by both parties and pursuant to action of the Governing Board of the District. This Agreement shall be governed by the laws of the State of California.

IN WITNESS WHEREOF, the parties hereto have caused this Agreement to be executed.

IRVINE UNIFIED SCHOOL DISTRICT

CONTRACTOR

By: \_\_\_\_\_  
Signature

By: \_\_\_\_\_  
Signature

\_\_\_\_\_  
Print Name

\_\_\_\_\_  
Print Name

\_\_\_\_\_  
Title

\_\_\_\_\_  
Title

\_\_\_\_\_  
Date

\_\_\_\_\_  
Date

Irvine Unified School District  
Board Approval Date

\_\_\_\_\_  
**Contractor's License No.**

\_\_\_\_\_  
Tax ID No.  
(Corporate Seal of Contractor,  
if corporation)



**PAYMENT BOND**

KNOW ALL PERSONS BY THESE PRESENT:

WHEREAS, the Irvine Unified School District of Orange County, California ("hereinafter referred to as DISTRICT"), has awarded to \_\_\_\_\_ (hereinafter referred to as the "Contractor/Principal") a contract for the work described as **Bid No. 24/25-02MO, Unit Cost Pricing for Concrete;**

WHEREAS, said Contractor/Principal is required by Division 3, Part IV, Title XV, Chapter 7 (commencing at Section 3247) of the California Civil Code to furnish a bond in connection with said contract;

NOW, THEREFORE, we, the Contractor/Principal and \_\_\_\_\_, as Surety, a California admitted surety insurer, are held firmly bound unto the DISTRICT for one hundred percent (100%) of the total amount payable by the DISTRICT under the terms of the contract awarded by the DISTRICT to the Contractor/Principal lawful money of the United States of America for the payment of which sum well and truly to be made, we bind ourselves, our heirs, executors, administrators, successors and assigns, jointly and severally, firmly by these presents.

THE CONDITION OF THIS OBLIGATION IS SUCH that if said Contractor/Principal, his/her or its heirs, executors, administrators, successors, or assigns, or a subcontractor, shall fail to pay any person or persons named in Civil Code Section 3181 or fail to pay for any materials, or other supplies, used in, upon, for, or about the performance of the work contracted to be done, or for any work or labor thereon of any kind, or for amounts due under the Unemployment Insurance Code, with respect to work or labor thereon of any kind, or shall fail to deduct, withhold, and pay over to the Employment Development Department, any amounts required to be deducted, withheld, and paid over by Section 13020 of the Unemployment Insurance Code with respect to work and labor thereon of any kind, then said Surety will pay for the same, in or to an amount not exceeding the amount hereinabove set forth, and also will pay in case suit is brought upon this bond, such reasonable attorney's fees as shall be fixed by the court, awarded and taxed as provided in Division 3, Part IV, Title XV, Chapter 7 (commencing at Section 3247) of the California Civil Code.

This bond shall inure to the benefit of any of the persons named in Section 3181 of the California Civil Code, so as to give a right of action to such person or their assigns in any suit brought upon this bond.

It is further stipulated and agreed that the Surety of this bond shall not be exonerated or released from the obligation of the bond by any change, extension of time for performance, addition, alteration or modification in, to, or of any contract, plans, specifications, or agreement pertaining or relating to any scheme or work of improvement hereinabove described or pertaining or relating to the furnishing of labor, materials, or equipment therefore, nor by any change or modification of any terms of payment or extension of the time for any payment pertaining or relating to any scheme or work of improvement hereinabove described, nor by any rescission or

attempted rescission of the contract, agreement or bond, nor by any conditions precedent or subsequent in the bond attempting to limit the right of recovery of claimants otherwise entitled to recover under any such contract or agreement or under the bond, nor by any fraud practiced by any person other than the claimant seeking to recover on the bond and that this bond be construed most strongly against the Surety and in favor of all persons for whose benefit such bond is given, and under no circumstances shall Surety be released from liability to those for whose benefit such bond has been given, by reason of any breach of contract between the DISTRICT and original contractor or on the part of any obligee named in such bond, but the sole conditions of recovery shall be that claimant is a person described in Section 3110 and 3112 of the California Civil Code, and has not been paid the full amount of his/her or its claim and that Surety does hereby waive notice of any such change, extension of time, addition, alteration or modification herein mentioned.

Any claims under this bond may be addressed to:

\_\_\_\_\_ (Name and address of Surety)

\_\_\_\_\_ (Name and address of agent or  
representative in California,  
if different from above)

\_\_\_\_\_ (Telephone and facsimile number of  
Surety or agent or representative  
in California)



IN WITNESS HEREOF, we have here to set our hands and seals on this \_\_\_\_ day of \_\_\_\_\_, 20\_\_.

CORPORATE SEAL, IF  
APPLICABLE, AND NOTARIAL  
ACKNOWLEDGEMENT OF  
CONTRACTOR

\_\_\_\_\_

\_\_\_\_\_  
Contractor/Principal

By:

\_\_\_\_\_  
Signature

\_\_\_\_\_  
Print Name and Title

SEAL AND NOTARIAL  
ACKNOWLEDGEMENT OF  
SURETY

\_\_\_\_\_

\_\_\_\_\_

\_\_\_\_\_

\_\_\_\_\_  
Surety

By: \_\_\_\_\_

\_\_\_\_\_  
Signature

(Mailing Address, Telephone and  
Facsimile No. of Surety)

\_\_\_\_\_

\_\_\_\_\_

\_\_\_\_\_

\_\_\_\_\_  
Print Name and Title

(Attach Attorney-in-Fact Certificate and  
Required Acknowledgement)

**FAITHFUL PERFORMANCE BOND**

KNOW ALL PERSONS BY THESE PRESENT:

WHEREAS, the Irvine Unified School District of Orange County, California (hereinafter referred to as "DISTRICT"), awarded to \_\_\_\_\_, (hereinafter referred to as the "Contractor/Principal") the contract for the work described as **Bid No. 24/25-02MO, Unit Cost Pricing for Concrete;**

WHEREAS, said Contractor/Principal is required under the terms of said contract to furnish a bond for the faithful performance of said contract which contract is incorporated herein by reference;

NOW, THEREFORE, we the undersigned Contractor, as Principal, and Surety, a California admitted surety insurer are held and firmly bound to the DISTRICT for one hundred percent (100%) of the total amount payable by the DISTRICT under the terms of the contract awarded by the DISTRICT to the Contractor/Principal, lawful money of the United States of America, for payment of which sum well and truly to be made, we bind ourselves, our heirs, executors, administrators and successors, jointly and severally, firmly by these presents.

THE CONDITION OF THIS OBLIGATION IS SUCH THAT, if the hereby bonded Contractor/Principal, its heirs, executors, administrators, successors, or assigns, shall in all things stand to and abide by and well and truly keep and perform all the undertakings, terms, covenants, conditions, and agreements in the said contract which is attached hereto and incorporated herein by reference and any alteration and/or amendments thereof, made as therein provided, including, but not limited to, the provisions regarding contract duration and liquidated damages, all within the time and in the manner therein designated in all respects according to their true intent and meaning, then this obligation shall become null and void; otherwise, it shall be and remain in full force and effect.

As a condition precedent to the satisfactory completion of the contract, the above obligation shall hold good for a period of **One (1)** years after the acceptance of the work by DISTRICT, during which time if Contractor/Principal shall fail to make full, complete, and satisfactory repair and replacements and totally protect the DISTRICT from loss or damage made evident during the period of **One (1)** years from the date of completion of the work, and resulting from or caused by defective materials or faulty workmanship, the above obligation in penal sum thereof shall remain in full force and effect. The obligation of Surety hereunder shall continue so long as any obligation of Contractor remains.

Whenever Contractor/Principal shall be, and is declared by the DISTRICT to be, in default under the contract, the DISTRICT having performed the DISTRICT's obligations thereunder, the Surety shall promptly remedy the default, or shall promptly:

1. Complete the contract in accordance with its terms and conditions; or

2. Obtain a bid or bids for completing the contract in accordance with its terms and conditions, and upon determination by Surety of the lowest responsive and responsible bidder, arrange for a contract between such bidder and the DISTRICT, and make available as work progresses sufficient funds to pay the cost of completion less the balance of the contract price, but not exceeding, including other costs and damages for which Surety may be liable hereunder, the amount set forth above. The term "balance of the contract price" as used in this paragraph shall mean the total amount payable to Contractor/Principal by the DISTRICT under the contract and any modifications thereto, less the amount previously properly paid by the DISTRICT to the Contractor/Principal.

Surety expressly agrees that the DISTRICT may reject any contractor or subcontractor which may be proposed by Surety in fulfillment of its obligations in the event of default by the Principal. Surety shall not utilize Contractor/Principal in completing the contract nor shall Surety accept a bid from Contractor/Principal for completion of the work if the DISTRICT, when declaring the Contractor/Principal in default, notifies Surety of the DISTRICT's objection to Contractor's/Principal's further participation in the completion of the work.

No right of action shall accrue on this bond to or for the use of any person or corporation other than the DISTRICT named herein or the successors or assigns of the DISTRICT. Any suit under this bond must be instituted within the applicable statute of limitations period.

FURTHER, the said Surety, for value received, hereby stipulates and agrees that no change, extension of time, alteration or modification of the Project documents, or of the work to be performed thereunder, shall in any way affect its obligations on this bond; and it does hereby waive notice of any change, extension of time, alteration or modification of the Project documents or of work to be performed thereunder.

Contractor/Principal and Surety agree that if the DISTRICT is required to engage the services of an attorney in connection with the enforcement of this bond, each shall pay DISTRICT's reasonable attorney's fees and costs incurred, with or without suit, in addition to the above amount.

IN WITNESS WHEREOF, we have hereunto set our hands and seals this \_\_\_\_\_ day of \_\_\_\_\_, 20\_\_.

CORPORATE SEAL, IF APPLICABLE, AND NOTARIAL ACKNOWLEDGEMENT OF CONTRACTOR

\_\_\_\_\_  
Contractor/Principal

By: \_\_\_\_\_  
Signature

\_\_\_\_\_  
Print Name and Title

SEAL AND NOTARIAL ACKNOWLEDGEMENT OF SURETY

\_\_\_\_\_  
Surety

By: \_\_\_\_\_  
Signature

(Mailing Address, Telephone No. and Facsimile No. of Surety)

\_\_\_\_\_  
Print Name and Title

\_\_\_\_\_  
\_\_\_\_\_  
\_\_\_\_\_

(Attach Attorney-in-Fact Certificate and Required Acknowledgement)

**WORKERS' COMPENSATION CERTIFICATE**

Labor Code Section 3700.

"Every employer except the state shall secure the payment of compensation in one or more of the following ways:

(a) By being insured against liability to pay compensation in one or more insurers duly authorized to write compensation insurance in this state.

(b) By securing from the Director of Industrial Relations a certificate of consent to self-insure either as an individual employer or as one employer in a group of employers, which may be given upon furnishing proof satisfactory to the Director of Industrial Relations of ability to self-insure and to pay any compensation that may become due to his or her employees.

(c) For any county, city, city and county, municipal corporation, public district, public agency or any political subdivision of the state, including each member of a pooling arrangement under a joint exercise of powers agreement (but not the state itself), by securing from the Director of Industrial Relations a certificate of consent to self-insure against workers' compensation claims, which certificate may be given upon furnishing proof satisfactory to the director of ability to administer workers' compensation claims properly, and to pay workers' compensation claims that may become due to its employees. On or before March 31, 1979, a political subdivision of the state which, on December 31, 1978, was uninsured for its liability to pay compensation, shall file a properly completed and executed application for a certificate of consent to self-insure against workers' compensation claims. The certificate shall be issued and be subject to the provisions of Section 3702."

I am aware of the provisions of Labor Code Section 3700 which require every employer to be insured against liability for workers' compensation or to undertake self-insurance in accordance with the provisions of that code, and I will comply with such provisions before commencing the performance of the work of this contract.

\_\_\_\_\_  
Name of the Contractor

By: \_\_\_\_\_  
Signature

\_\_\_\_\_  
Print Name

\_\_\_\_\_  
Title

\_\_\_\_\_  
Date

(In accordance with Article 5 [commencing at Section 1860], Chapter 1, Part 7, Division 2 of the Labor Code, the above certificate must be signed and filed with the awarding body prior to performing any work under the contract.)

## DRUG-FREE WORKPLACE CERTIFICATION

This Drug-Free Workplace Certification is required pursuant to Government Code Sections 8350, et seq., the Drug-Free Workplace Act of 1990. The Drug-Free Workplace Act of 1990 requires that every person or organization awarded a contract for the procurement of any property or services from any State agency must certify that it will provide a drug-free workplace by doing certain specified acts. In addition, the Act provides that each contract awarded by a State agency may be subject to suspension of payments or termination of the contract, and the contractor may be subject to debarment from future contracting, if the state agency determines that specified acts have occurred.

Pursuant to Government Code Section 8355, every person or organization awarded a contract from a State agency shall certify that it will provide a drug-free workplace by doing all of the following:

- a) publishing a statement notifying employees that the unlawful manufacture, distribution, dispensation, possession or use of a controlled substance is prohibited in the person's or organization's workplace and specifying actions which will be taken against employees for violations of the prohibition;
- b) establishing a drug-free awareness program to inform employees about all of the following:
  - 1) the dangers of drug abuse in the workplace;
  - 2) the person's or organization's policy of maintaining a drug-free workplace;
  - 3) the availability of drug counseling, rehabilitation and employee-assistance programs;
  - 4) the penalties that may be imposed upon employees for drug abuse violations;
- c) requiring that each employee engaged in the performance of the contract be given a copy of the statement required by subdivision (a) and that, as a condition of employment on the contract, the employee agrees to abide by the terms of the statement.

I, the undersigned, agree to fulfill the terms and requirements of Government Code Section 8355 listed above and will publish a statement notifying employees concerning (a) the prohibition of controlled substance at the workplace, (b) establishing a drug-free awareness program, and (c) requiring that each employee engaged in the performance of the contract be given a copy of the statement required by Section 8355(a) and requiring that the employee agree to abide by the terms of that statement.

I also understand that if the DISTRICT determines that I have either (a) made a false certification herein, or (b) violated this certification by failing to carry out the requirements of Section 8355,

that the contract awarded herein is subject to suspension of payments, termination, or both. I further understand that, should I violate the terms of the Drug-Free Workplace Act of 1990, I may be subject to debarment in accordance with the requirements of Section 8350, et seq.

I acknowledge that I am aware of the provisions of Government Code Section 8350, et seq. and hereby certify that I will adhere to the requirements of the Drug-Free Workplace Act of 1990.

\_\_\_\_\_  
NAME OF CONTRACTOR

\_\_\_\_\_  
Signature

\_\_\_\_\_  
Print Name

\_\_\_\_\_  
Title

\_\_\_\_\_  
Date

SAMPLE

**CONTRACTOR'S CERTIFICATE REGARDING  
NON-ASBESTOS CONTAINING MATERIALS**

Per Article 69 of the General Conditions.

**Certification for** \_\_\_\_\_ from \_\_\_\_\_ through \_\_\_\_\_. We hereby certify that no Asbestos, or Asbestos Containing Materials shall be used in this Project or in any tools, devices, clothing, or equipment used to affect the \_\_\_\_\_ which we have installed in the Irvine Unified School District.

- (a) The Contractor further certifies that he/she has instructed his/her employees with respect to the above mentioned standards, hazards, risks and liabilities.
- (b) Asbestos and/or asbestos containing material shall be defined as all items containing but not limited to chrysotile, corcidolite, amosite, anthophyllite, tremolite and actinolite.
- (c) Any or all material containing greater than one-tenth of one percent (.1%) asbestos shall be defined as asbestos containing material.
- (d) Any disputes involving the question of whether or not material contains asbestos shall be settled by electron microscopy. The costs of any such tests shall be paid by the Contractor if the material is found to contain asbestos.
- (e) All work or materials found to contain asbestos or work or material installed with asbestos containing equipment will be immediately rejected and this work will be removed at no additional cost to the District.

\_\_\_\_\_  
Date

\_\_\_\_\_  
Name of Contractor

By: \_\_\_\_\_  
Signature

\_\_\_\_\_  
Print Name

\_\_\_\_\_  
Title



**TOBACCO USE POLICY**

**IRVINE UNIFIED SCHOOL DISTRICT**  
Irvine, California

In the interest of public health, the Irvine Unified School District provides a tobacco-free environment. Smoking or the use of any tobacco products are prohibited in buildings and vehicles, and on any property owned, leased or contracted for, by the District. Failure to abide with this requirement could result in the termination of this contract.

I acknowledge that I am aware of Tobacco Use Policy and hereby certify that I and my employees will adhere to the requirements of the policy.

\_\_\_\_\_  
Name of Bidder

\_\_\_\_\_  
Signature

\_\_\_\_\_  
Date

**NOTICE TO CONTRACTORS REGARDING CRIMINAL RECORDS CHECK**  
**(EDUCATION CODE SECTION 45125.1)**

Education Code Section 45125.1 provides that anyone who has a contract with a local education agency (school district) shall ensure that any employee who interacts with students outside of the immediate supervision and control of the student's parent or guardian or a District/school employee has a valid criminal records summary resulting from submission of the employee's fingerprints in a manner authorized by the Department of Justice (DOJ).

The DOJ shall ascertain whether the individual whose fingerprints were submitted to it has been arrested or convicted of any crime insofar as that fact can be ascertained from information available to the DOJ.

**The entity shall not permit an employee to come in contact with any student until the DOJ has ascertained that the employee has not been convicted of a violent felony as defined in Penal Code section 667.5(c) or serious felony as defined in Penal Code section 1192.7(c). The entity shall certify in writing to the governing board of the school district that none of its employees who may come in contact with any student have been convicted of a violent or serious felony.**

**CRIMINAL RECORDS CHECK**  
**CERTIFICATION BY CONTRACTOR**

To the Governing Board of Irvine Unified School District:

I, \_\_\_\_\_, am the \_\_\_\_\_, of \_\_\_\_\_  
Name of Individual Title Name of Contractor  
and I am authorized to execute this Certification on behalf of the Contractor.

1. I have carefully read and understand the Notice to Contractors Regarding a Valid Criminal Record Summary required under Education Code Section 45125.1.
2. Due to the nature of the services that will be provided to the District, Contractor's employees will or may have contact with students of the District outside of the immediate supervision and control of the student's parent or guardian or District employee.
3. I have obtained and reviewed the valid Criminal Records Summary of my employees who will be performing services for the District. If any subsequent/future employees will be performing services for the District, I will obtain and review the Valid Criminal Records Summary of these employees and submit an updated Certification to the District.
4. None of the employees who will be performing the services to the District have been convicted of a violent felony as defined in Penal Code section 667.5(c) or serious felony as defined in Penal Code Section 1192.7(c), and this determination was made by a fingerprint check through the Department of Justice.

I declare under penalty of perjury, under the laws of the State of California, that the foregoing is true and correct.

Executed at \_\_\_\_\_, California on \_\_\_\_\_.  
Date

\_\_\_\_\_  
Signature

\_\_\_\_\_  
Typed or Printed Name

\_\_\_\_\_  
Title

\_\_\_\_\_  
Name of Contractor

## DISTRICT RULES AND REGULATIONS

### MAINTENANCE & OPERATIONS

100 Nightmist, Irvine, CA 92618

(949) 936-5300 fax (949) 936-5309

The following rules and regulations must be followed by every contractor doing business with Irvine Unified School District. Failure to comply may result in the removal of you and/or members of your crew from the job, and possible back charges for our direct costs.

1. This a tobacco, drug and alcohol free school district; **no tobacco products, drug products or vaping** may be used on District property.
2. The District reserves the right in its sole discretion to utilize other contractors for work required by the District.
3. All of the City of Irvine's laws relating to hours and noise of construction work must be followed. If you want to work other than, 7:00 am - 6:00pm or dusk (whichever is earlier) Monday through Friday, or 9:00am - 5:00pm Saturday, you must get a waiver from the City.
4. No pets are allowed on district property.
5. Anyone not directly involved in the scope of work shall not be on the job site.
6. No music, i.e. radios, cassettes, CD's, or headphones, etc.
7. No district equipment shall be used by any contractor unless specifically allowed in writing prior to the start of work. (phone, vacuum, ladders, trash cans or bins, microwave, etc.)
8. Any contractor working on a site where students are present must supply the District with certification that all employees on the project have been finger printed and approved per state law.
9. Fraternalization or other contact with students is strictly forbidden.
10. The contractor shall, prior to the start of work, provide the District with the required Certificate of Insurance documents.
11. The contractor must clean up all debris from the course of work daily. This includes sweeping, vacuuming, hosing down and other appropriate measures. Any and all damage to the district's property caused by the contractor's equipment or materials shall be repaired to the district's satisfaction.
12. All employees and subcontractors shall act in a professional manner and wear a shirt or uniform with the company name and logo plainly visible. All other clothing shall be free from holes and any inappropriate logos or patches.

13. Any contractor that loses site keys may be billed for the full cost of rekeying the site.
14. The contractor will only make changes at the request of the District's Facilities/ Construction or Maintenance Departments Director, Supervisor, Foreman, or Inspector.
15. The contractor is responsible for locating any and all utilities and other appurtenances that may be affected by this project. Any and all damage is the contractor's responsibility to repair to the District's satisfaction. The District will make available any as-built documents in its possession to the contractor for review at his request. The District does not guarantee the accuracy of the documents and it is the contractor's responsibility to verify the actual location of utilities and appurtenances.
16. Contractor is responsible for security of the entire project area, including fencing if necessary to protect the District and contractor from liability relative to the project. Any contractor that leaves a building unsecured will be liable for any loss incurred or the direct cost to the district to secure the building. The district's labor agreement requires a four (4) hour minimum payment for after hour call outs.
17. Any items issued to the contractor (keys, badges, alarm cards, etc.) shall be returned prior to final payment.
18. Any project over \$1,000.00 is a prevailing wage project. Labor Code Section 1770-1771. ([www.dir.ca.gov](http://www.dir.ca.gov)). SB854 requires contractor to be registered with the Department of Industrial Relations.
19. Firearms or weapons of any type are strictly prohibited on school district property.
20. Contractor to provide payment bond for projects over \$25,000.
21. Contractor to provide performance bond for projects over \$25,000.
22. Contractor will be required to provide certified payroll records on all projects.
23. Contractors shall follow the California Department of Public Health regulations as it pertains to COVID-19.

**Please read both pages of this document. Your signature indicates you have read, understand, and agree to this document.**

\_\_\_\_\_  
Signature

\_\_\_\_\_  
Date

**GUARANTEE**

**Guarantee for workmanship.** We hereby guarantee that the workmanship, which we have installed in \_\_\_\_\_ from \_\_\_\_\_ through \_\_\_\_\_, has been done in accordance with the Project Documents and that the work as installed will fulfill the requirements included in the Project Documents. The undersigned agrees to repair or replace any or all of such work, together with any other adjacent work which may be displaced in connection with such repair or replacement, that may prove to be defective in workmanship or material within a period of \_\_\_\_\_ years from the date of completion of the Project, ordinary wear and tear and unusual abuse or neglect excepted.

In the event of the undersigned's or undersigned surety's failure to commence and pursue with diligence said repairs or replacements within ten (10) calendar days after being notified in writing by the DISTRICT, the undersigned authorizes the DISTRICT to proceed to have said defects repaired or replaced and made good at the expense of the undersigned and surety who hereby agree to pay the costs and charges therefore immediately upon demand. (General Conditions Article 46(d))

\_\_\_\_\_  
Name of Contractor

By: \_\_\_\_\_  
Signature of Contractor

\_\_\_\_\_  
Print Name

\_\_\_\_\_  
Title

Contractor shall provide copy of this Guarantee to Contractor's surety.

**Guarantee** (continued)

\_\_\_\_\_  
Name of Subcontractor  
(if work performed by  
subcontractor)

By: \_\_\_\_\_  
Signature of Subcontractor

\_\_\_\_\_  
Print Name

\_\_\_\_\_  
Title

Representatives to be contacted for service:

Name: \_\_\_\_\_

Address: \_\_\_\_\_

Telephone Number: \_\_\_\_\_

**ESCROW AGREEMENT FOR  
SECURITY DEPOSITS IN LIEU OF RETENTION**

This Escrow Agreement is made and entered into, as of \_\_\_\_\_, 20\_\_\_\_, by and between \_\_\_\_\_, whose address is \_\_\_\_\_, hereinafter called "DISTRICT;" \_\_\_\_\_, whose address is \_\_\_\_\_, hereinafter called "Contractor;" and, \_\_\_\_\_, whose address is \_\_\_\_\_, hereinafter called "Escrow Agent."

For the consideration hereinafter set forth, the DISTRICT, Contractor, and Escrow Agent agree as follows:

(1) Pursuant to Section 22300 of the Public Contract Code of the State of California, Contractor has the option to deposit securities with Escrow Agent as a substitute for retention earnings required to be withheld by DISTRICT pursuant to the Agreement entered into between the DISTRICT and Contractor for \_\_\_\_\_ in the amount of \_\_\_\_\_,

(Name of Project)

dated \_\_\_\_\_ (hereinafter referred to as the "Agreement"). Alternatively, on written request of the Contractor, the DISTRICT shall make payments of the retention earnings directly to the Escrow Agent. When the Contractor deposits the securities as a substitute for retention earnings, the Escrow Agent shall notify the DISTRICT within ten (10) days of the deposit. The market value of the securities at the time of the substitution shall be at least equal to the cash amount then required to be withheld as retention under the terms of the Agreement between the DISTRICT and Contractor. Securities shall be held in the name of DISTRICT, and shall designate the Contractor as the beneficial owner.

(2) The DISTRICT shall make progress payments to the Contractor for those funds which otherwise would be withheld from progress payments, provided that the Escrow Agent holds securities in the form and amount specified above.

(3) When the DISTRICT makes payment of retentions earned directly to the Escrow Agent, the Escrow Agent shall hold them for the benefit of the Contractor until the time the escrow created under this Escrow Agreement is terminated. The Contractor may direct the investment of the payments into securities. All terms and conditions of this Escrow Agreement and the rights and responsibilities of the parties shall be equally applicable and binding when the DISTRICT pays the Escrow Agent directly.

(4) Contractor shall be responsible for paying all fees for the expenses incurred by Escrow Agent in administering the Escrow Account and all expenses of the DISTRICT. These expenses and payment terms shall be determined by the DISTRICT, Contractor and Escrow Agent.



(5) The interest earned on the securities or the money market accounts held in escrow and all interest earned on that interest shall be for the sole account of Contractor and shall be subject to withdrawal by Contractor at any time and from time to time without notice to the DISTRICT.

(6) Contractor shall have the right to withdraw all or any part of the principal in the Escrow Account only by written notice to Escrow Agent accompanied by written authorization from the DISTRICT to the Escrow Agent that DISTRICT consents to the withdrawal of the amount sought to be withdrawn by Contractor.

(7) The DISTRICT shall have a right to draw upon the securities in the event of default by the Contractor. Upon seven (7) days' written notice to the Escrow Agent from the DISTRICT of the default, the Escrow Agent shall immediately convert the securities to cash and shall distribute the cash as instructed by the DISTRICT.

(8) Upon receipt of written notification from the DISTRICT certifying that the Agreement is final and complete, and that the Contractor has complied with all requirements and procedures applicable to the Agreement, Escrow Agent shall release to Contractor all securities and interest on deposit less escrow fees and charges of the Escrow Account. The escrow shall be closed immediately upon disbursement of all monies and securities on deposit and payments of fees and charges.

(9) Escrow Agent shall rely on the written notifications from the DISTRICT and the Contractor pursuant to Sections (5) to (8), inclusive, of this Escrow Agreement and the DISTRICT and Contractor shall hold Escrow Agent harmless from Escrow Agent's release and disbursement of the securities and interest as set forth above.

(10) The names of the persons who are authorized to give written notice or to receive written notice on behalf of the DISTRICT and on behalf of Contractor in connection with the foregoing, and exemplars of their respective signatures are as follows:

On behalf of DISTRICT:

On behalf of Contractor:

\_\_\_\_\_

Title

\_\_\_\_\_

Title

\_\_\_\_\_

Name

\_\_\_\_\_

Name

\_\_\_\_\_

Signature

\_\_\_\_\_

Signature

\_\_\_\_\_

Address

\_\_\_\_\_

Address

On behalf of Escrow Agent:

\_\_\_\_\_  
Title

\_\_\_\_\_  
Name

\_\_\_\_\_  
Signature

\_\_\_\_\_  
Address

At the time the Escrow Account is opened, the DISTRICT and Contractor shall deliver to the Escrow Agent a fully executed counterpart of this Escrow Agreement.

IN WITNESS WHEREOF, the parties have executed this Escrow Agreement by their proper officers on the date first set forth above.

DISTRICT

Contractor

\_\_\_\_\_  
Title

\_\_\_\_\_  
Title

\_\_\_\_\_  
Name

\_\_\_\_\_  
Name

\_\_\_\_\_  
Signature

\_\_\_\_\_  
Signature

Escrow Agent

\_\_\_\_\_  
Title

\_\_\_\_\_  
Name

\_\_\_\_\_  
Signature

**SHOP DRAWING TRANSMITTAL**

The procedure governing shop drawing submittals is contained in the General Conditions. In addition, all Supplemental Conditions, Special Conditions and Specifications must be followed by the CONTRACTOR.

Failure to comply with all requirements will constitute grounds for return of the shop drawing for proper resubmittal. CONTRACTOR shall sequentially number each submittal.

Date: \_\_\_\_\_ Submittal No.: \_\_\_\_\_

From: \_\_\_\_\_ To: \_\_\_\_\_

Project Name: \_\_\_\_\_

This is a(n):    Original    \_\_\_\_\_  
    Submittal    \_\_\_\_\_  
    2nd Submittal    \_\_\_\_\_  
    [ ] Submittal    \_\_\_\_\_

---

Subject of Submittal:	Equipment Designation:	Specification Section(s):
-----------------------	------------------------	---------------------------

Complete either (a) or (b)

Check One:

(a) We have verified that the material or equipment contained in this submittal meets all the requirements specified or shown (no exceptions). \_\_\_\_\_

(b) We have verified that the material or equipment contained in this submittal meets all the requirements specified or shown, except for the following deviations (List deviations on attached sheet). \_\_\_\_\_

(continued on next page)

The CONTRACTOR has reviewed and approved not only the field dimensions but the construction criteria and has also made written notation regarding any information in the shop drawings that does not conform to the Project Documents. This shop drawing has been coordinated with all other shop drawings received to date by CONTRACTOR and this duty of coordination has not been delegated to subcontractors, material suppliers, the ARCHITECT, or the engineers on this Project.

\_\_\_\_\_  
Signature of Contractor or Supplier

**Equipment/Material Source Information (OPTIONAL)**

The name of the manufacturer of each piece of equipment that will be installed in this Project shall be set forth below. Only one manufacturer of each piece of equipment shall be listed. Bidder agrees that in the event any listed manufacturer is not specifically named in the Project Documents, it will, prior to award, submit complete information satisfactory to the Architect that such manufacturer's equipment complies with all requirements of the Project Documents. If, in the opinion of the Architect, the listed manufacturer's equipment does not comply with the Project Documents, the bid may be rejected unless, prior to award, the bidder agrees in writing to supply approved equipment without a change in the bid price.

<u>Equipment/Material</u>	<u>Manufacturer</u>
_____	_____
_____	_____
_____	_____
_____	_____
_____	_____
_____	_____
_____	_____
_____	_____
_____	_____
_____	_____

**CHANGE ORDER NO.**

(Additive)

PROJECT: \_\_\_\_\_

TO: \_\_\_\_\_

You are hereby directed to provide the extra work necessary to comply with this Change Order.

DESCRIPTION OF CHANGE: \_\_\_\_\_

\_\_\_\_\_

COST (This cost shall not be exceeded.):

Original contract price: \$ \_\_\_\_\_  
Change Order amount: \$ \_\_\_\_\_  
New contract price: \$ \_\_\_\_\_

TIME FOR COMPLETION:

Original completion date: \_\_\_\_\_  
Time for completion of  
Change Order: \_\_\_\_\_  
New completion date: \_\_\_\_\_

Contractor agrees to perform the above-described work in accordance with the above terms and in compliance with applicable sections of the Project Documents. The amount of the charges under this Change Order is limited to the charges allowed under Article 59 of the General Conditions. The adjustment in the contract sum, if any, and the adjustment in the contract time, if any, set out in this Change Order shall constitute the entire compensation and/or adjustment in the contract time due Contractor arising out of the change in the work covered by this Change Order, unless otherwise provided in this Change Order.

No additions or deletions to this Change Order shall be allowed, except with written permission of District. Contractor accepts the terms and conditions stated above as full and final settlement of any and all claims arising from this Change Order.

(continued on next page)

This Change Order is hereby agreed to, accepted and approved.

CONTRACTOR

DISTRICT

By: \_\_\_\_\_  
Signature

By: \_\_\_\_\_  
Signature

\_\_\_\_\_  
Print Name

\_\_\_\_\_  
Print Name

\_\_\_\_\_  
Title

\_\_\_\_\_  
Title

\_\_\_\_\_  
Date

\_\_\_\_\_  
Date

ARCHITECT

By: \_\_\_\_\_  
Signature

\_\_\_\_\_  
Print Name

\_\_\_\_\_  
Title

\_\_\_\_\_  
Date

**CHANGE ORDER NO.**

(Deductive)

PROJECT: \_\_\_\_\_

TO: \_\_\_\_\_

You are hereby directed to comply with this Change Order.

DESCRIPTION OF CHANGE: \_\_\_\_\_

\_\_\_\_\_

COST (This cost shall be deleted.):

Original contract price: \$ \_\_\_\_\_  
Change Order amount: \$ \_\_\_\_\_  
New contract price: \$ \_\_\_\_\_

TIME FOR COMPLETION:

Original completion date: \_\_\_\_\_  
Time for completion of  
Change Order: \_\_\_\_\_  
New completion date: \_\_\_\_\_

Contractor agrees to deduct the above-described work in accordance with the above terms and in compliance with applicable sections of the Project Documents. Contractor agrees to the adjustment in the contract sum, if any, and the adjustment in the contract time, if any, set out in this Change Order.

No additions or deletions to this Change Order shall be allowed, except with written permission of District. Contractor accepts the terms and conditions stated above as full and final settlement of any and all claims arising from this Change Order.

(continued on next page)



This Change Order is hereby agreed to, accepted and approved.

CONTRACTOR

By: \_\_\_\_\_  
Signature

\_\_\_\_\_  
Print Name

\_\_\_\_\_  
Title

\_\_\_\_\_  
Date

DISTRICT

By: \_\_\_\_\_  
Signature

\_\_\_\_\_  
Print Name

\_\_\_\_\_  
Title

\_\_\_\_\_  
Date

ARCHITECT

By: \_\_\_\_\_  
Signature

\_\_\_\_\_  
Print Name

\_\_\_\_\_  
Title

\_\_\_\_\_  
Date

**STATE OF CALIFORNIA – DEPARTMENT OF INDUSTRIAL RELATIONS**

TO: California Department of Industrial Relations  
 Division of Apprenticeship Standards  
 P.O. Box 420603  
 San Francisco, CA 94142

AWARDING AGENCY ID NUMBER

--

If you do not have an ID number please contact DAS

FROM:

**EXTRACT OF  
PUBLIC WORKS CONTRACT AWARD**

A CONTRACT TO PERFORM PUBLIC WORKS UNDER LABOR CODE SECTION 1777.5 HAS BEEN AWARDED TO:

1. NAME OF GENERAL CONTRACTOR		2. CONTRACTOR'S LICENSE NO	
3. MAILING ADDRESS (STREET NUMBER OR P.O. BOX)		4. CITY	
		5. ZIP CODE	6. TELEPHONE NUMBER
7. GENERAL CONTRACTOR'S CONTACT EMAIL ADDRESS		8. ADDRESS/LOCATION OF PUBLIC WORKS SITE (INCLUDE CITY AND COUNTY):  Ba. County	
9. NAME OF PROJECT			
10. CONTRACT NUMBER	11. PROJECT NUMBER	12. DOLLAR AMOUNT OF CONTRACT AWARD	
13. FIRST ADVERTISED BID DATE MONTH DAY YEAR	14. CONTRACT AWARD DATE MONTH DAY YEAR	12a. ESTIMATED TOTAL PROJECT COSTS, IF DIFFERENT FROM ITEM 12 (see instructions)	
		15. WHICH STATUTE, IF ANY, APPLIES TO THIS PROJECT?	
16. STATE CONSTRUCTION BONDS If YES, List the Sources and Dollar Amount of Bond Proceeds: SOURCES	YES NO DOLLAR AMOUNT	17. WILL YOU OPERATE A DIR-APPROVED LABOR COMPLIANCE PROGRAM (LCP) FOR THIS PROJECT?  YES NO	
		18. IS THERE A PROJECT LABOR AGREEMENT (PLA) ASSOCIATED WITH THIS PROJECT? If yes, please email a copy to <a href="mailto:crmpia@dir.ca.gov">crmpia@dir.ca.gov</a>  YES NO	
		20. COMPLETION DATE (ESTIMATED OR ACTUAL)  (MM/DD/YYYY)	
19. STARTING DATE (ESTIMATED OR ACTUAL)  (MM/DD/YYYY)		21. BRIEF DESCRIPTION OF WORK TO BE PERFORMED	
		22.  NEW CONSTRUCTION REMODELING  ALTERATION, DEMOLITION, REPAIR OR MAINTENANCE	
23. CLASSIFICATION OR TYPE OF WORKER (CARPENTER, PLUMBER, ETC.) THAT WILL BE EMPLOYED BY THE CONTRACTOR(S)  Please list sub-contractors and their worker classifications on page 2			
24. Is language included in the Contract Award to effectuate the requirements of sections 1771, 1774, 1775, 1776, 1777.5, 1813, and 1815 of the Labor Code?		YES	NO
25. SIGNATURE	26. TITLE	27. DATE	
28. PRINTED OR TYPED NAME	29. E-MAIL ADDRESS	30. TELEPHONE NUMBERS	
If different from above, name, title, and contact information of person responsible for carrying out Awarding Body's LCP or CMU responsibilities.			
31. NAME	32. TITLE	33. E-MAIL ADDRESS	34. TELEPHONE NUMBER

Duplication of this form is permissible



**CERTIFICATION – PARTICIPATION OF  
DISABLED VETERAN BUSINESS ENTERPRISES  
IN ACCORDANCE WITH EDUCATION CODE 17076.11**

In accordance with Education Code Section 17076.11, the \_\_\_\_\_ School District has a participation goal for Disabled Veteran Business Enterprises of at least three percent (3%) per year of the overall dollar amount of funds allocated by the District by the State Allocation Board pursuant to the Leroy F. Greene School Facilities Act of 1998 for construction or modernization of school buildings and expended each year by the District. At the time of execution of the contract, the Contractor will provide a statement to the District of anticipated participation of Disabled Veteran Business Enterprises in the contract. Prior to, and as a condition precedent for final payment under the contract, the Contractor will provide appropriate documentation to the District identifying the amount paid to Disabled Veteran Business Enterprises pursuant to the contract, so that the District can assess its success at meeting this goal.

The Contractor may provide the anticipated participation of Disabled Veteran Business Enterprises in terms of percentage of its total contract or the dollar amount anticipated to be paid to Disabled Veteran Business Enterprises or by providing the names of the Disabled Veteran Business Enterprises that will participate in the contract. If there is a discrepancy between the anticipated goals and the actual goals at completion of the contract or a failure to meet the anticipated goal or dollar amounts, the District will require the Contractor to provide, at the completion of the contract, a detailed statement of the reason(s) for the discrepancy or failure to meet the anticipated goals or dollar amounts.

I certify that I have read the above and will comply with the anticipated participation of Disabled Veteran Business Enterprises in this contract.

\_\_\_\_\_  
Signature

\_\_\_\_\_  
Typed or Printed Name

\_\_\_\_\_  
Title

\_\_\_\_\_  
Company

\_\_\_\_\_  
Address

\_\_\_\_\_  
City, State, Zip

\_\_\_\_\_  
Telephone

\_\_\_\_\_  
Fax

\_\_\_\_\_  
E-mail

# SAMPLE

<b>ACORD™ CERTIFICATE OF LIABILITY INSURANCE</b>		DATE (MM/DD/YYYY) INSERT DATE
PRODUCER  NAME & ADDRESS OF INSURANCE COMPANY	THIS CERTIFICATE IS ISSUED AS A MATTER OF INFORMATION ONLY AND CONFERS NO RIGHTS UPON THE CERTIFICATE HOLDER. THIS CERTIFICATE DOES NOT AMEND, EXTEND OR ALTER THE COVERAGE AFFORDED BY THE POLICIES BELOW.	
INSURED  NAME & ADDRESS OF COMPANY/ORGANIZATION	INSURERS AFFORDING COVERAGE INSURER A: Name of Insurance Company INSURER B: Name of Insurance Company INSURER C: Name of Insurance Company INSURER D: Name of Insurance Company INSURER E: Name of Insurance Company	NAIC #

**COVERAGES**  
 THE POLICIES OF INSURANCE LISTED BELOW HAVE BEEN ISSUED TO THE INSURED NAMED ABOVE FOR THE POLICY PERIOD INDICATED. NOTWITHSTANDING ANY REQUIREMENT, TERM OR CONDITION OF ANY CONTRACT OR OTHER DOCUMENT WITH RESPECT TO WHICH THIS CERTIFICATE MAY BE ISSUED OR MAY PERTAIN, THE INSURANCE AFFORDED BY THE POLICIES DESCRIBED HEREIN IS SUBJECT TO ALL THE TERMS, EXCLUSIONS AND CONDITIONS OF SUCH POLICIES. AGGREGATE LIMITS SHOWN MAY HAVE BEEN REDUCED BY PAID CLAIMS.

INSR	ADD'L LTR	TYPE OF INSURANCE	POLICY NUMBER	POLICY EFFECTIVE DATE (MM/DD/YY)	POLICY EXPIRATION DATE (MM/DD/YY)	LIMITS
		<b>GENERAL LIABILITY</b> <input checked="" type="checkbox"/> COMMERCIAL GENERAL LIABILITY <input type="checkbox"/> CLAIMS MADE <input checked="" type="checkbox"/> OCCUR  GEN'L AGGREGATE LIMIT APPLIES PER: <input type="checkbox"/> POLICY <input type="checkbox"/> PRO-JECT <input type="checkbox"/> LOC	<b>MANDATORY REQUIREMENTS</b>	Insert Date	Insert Date	EACH OCCURRENCE \$ 1,000,000 DAMAGE TO RENTED PREMISES (Ea occurrence) \$ 50,000 MED EXP (Any one person) \$ 5,000 PERSONAL & ADV INJURY \$ 1,000,000 GENERAL AGGREGATE \$ 2,000,000 PRODUCTS - COMP/OP AGG \$ 1,000,000
		<b>AUTOMOBILE LIABILITY</b> <input checked="" type="checkbox"/> ANY AUTO <input type="checkbox"/> ALL OWNED AUTOS <input type="checkbox"/> SCHEDULED AUTOS <input type="checkbox"/> HIRED AUTOS <input type="checkbox"/> NON-OWNED AUTOS	<b>REQUIRED IF APPLICABLE TO SERVICE</b>	Insert Date	Insert Date	COMBINED SINGLE LIMIT (Ea accident) \$ 1,000,000 BODILY INJURY (Per person) \$ BODILY INJURY (Per accident) \$ PROPERTY DAMAGE (Per accident) \$
		<b>GARAGE LIABILITY</b> <input type="checkbox"/> ANY AUTO				AUTO ONLY - EA ACCIDENT \$ OTHER THAN EA ACC \$ AUTO ONLY: AGG \$
		<b>EXCESS/UMBRELLA LIABILITY</b> <input checked="" type="checkbox"/> OCCUR <input type="checkbox"/> CLAIMS MADE  <input type="checkbox"/> DEDUCTIBLE <input type="checkbox"/> RETENTION \$	<b>REQUIRED UNLESS REDUCED/EXCLUDED</b>	Insert Date	Insert Date	EACH OCCURRENCE \$ 3,000,000 AGGREGATE \$ \$ \$
		<b>WORKERS COMPENSATION AND EMPLOYERS' LIABILITY</b> ANY PROPRIETOR/PARTNER/EXECUTIVE OFFICER/MEMBER EXCLUDED? If yes, describe under SPECIAL PROVISIONS below	<b>REQUIRED UNLESS REDUCED/EXCLUDED</b>	Insert Date	Insert Date	<input checked="" type="checkbox"/> WC STATUTORY LIMITS <input type="checkbox"/> OTHER E.L. EACH ACCIDENT \$ 1,000,000 E.L. DISEASE - EA EMPLOYEE \$ 1,000,000 E.L. DISEASE - POLICY LIMIT \$ 1,000,000
		<b>OTHER</b> Professional Liability and/or Sexual Abuse/Molestation	<b>MAY BE REQUIRED</b>	Insert Date	Insert Date	\$ 1,000,000 per occurrence \$ 2,000,000 aggregate

**DESCRIPTION OF OPERATIONS/LOCATIONS/VEHICLES/EXCLUSIONS ADDED BY ENDORSEMENT/SPECIAL PROVISIONS**  
 Irvine Unified School District, its Board of Trustees, officers, agents, employees, and volunteers are named as additionally insured on this policy pursuant to written contract, agreement, or memorandum of understanding. Such insurance as is afforded by this policy shall be primary, and any insurance carried by District shall be excess and noncontributory. Sexual Abuse/Molestation is not excluded from coverage under the general liability and excess/umbrella liability policies. (Provide brief description of services/dates).

<b>CERTIFICATE HOLDER</b>  Irvine Unified School District 5050 Barranca Parkway Irvine, California 92604 Attention: Risk Management	<b>CANCELLATION</b>  SHOULD ANY OF THE ABOVE DESCRIBED POLICIES BE CANCELLED BEFORE THE EXPIRATION DATE THEREOF, THE ISSUING INSURER WILL ENDEAVOR TO MAIL <u>30</u> DAYS WRITTEN NOTICE TO THE CERTIFICATE HOLDER NAMED TO THE LEFT, BUT FAILURE TO DO SO SHALL IMPOSE NO OBLIGATION OR LIABILITY OF ANY KIND UPON THE INSURER, ITS AGENTS OR REPRESENTATIVES.  AUTHORIZED REPRESENTATIVE SIGNATURE REQUIRED
--	---

## ENDORSEMENT

### ADDITIONAL COVERED PARTY

**COVERED PARTY**

(INSERT INSURED NAME)

**COVERAGE DOCUMENT**

(INSERT POLICY NUMBER)

**ADMINISTRATOR**

(INSERT NAME OF ADMINISTRATOR)

Subject to all terms, conditions, exclusions, and endorsements, such additional covered party as is afforded by the coverage document shall also apply to the following entity but only as respects to liability arising from the actions and activities of the covered party described below.

**Additional Covered Party:**

Irvine Unified School District  
5050 Barranca Parkway  
Irvine, California 92604

**Description of Activities:**

Irvine Unified School District, its Board of Trustees, officers, agents, employees, and volunteers are named as additionally insured on this policy pursuant to written contract, agreement, or memorandum of understanding. Such insurance as is afforded by this policy shall be primary, and any insurance carried by District shall be excess and noncontributory.

Authorized Representative Signature  
MUST APPEAR ON THE ENDORSEMENT PAGE

# SAMPLE



# Irvine Unified School District Insurance Requirements

**All insurers must be duly licensed and admitted by the State of California**

**Mandatory Requirements (unless District reduces or excludes coverage requirements)**

1. Commercial General Liability insurance for bodily injury and property damage, including accidental death in the combined single limit of not less than \$1,000,000 per occurrence (\$2,000,000 aggregate) and \$3,000,000 Excess/Umbrella Liability.
2. Sexual Abuse/Molestation coverage must be included under General Liability or obtained in separate policies in an amount of not less than \$1,000,000 per occurrence (\$2,000,000 aggregate) and \$3,000,000 excess/umbrella coverage.

**Minimum Limits (if required by District)**

1. Automobile Liability insurance for bodily injury and property damage in an amount of not less than \$1,000,000 per occurrence with no annual aggregate limit.
2. Workers' Compensation and Employer's Liability insurance in the amount of not less than \$1,000,000 per occurrence.
3. Professional Liability insurance in an amount of not less than \$1,000,000 per occurrence (\$2,000,000 aggregate). If Professional Liability policy is made on a claims-made basis, the vendor/consultant must purchase and maintain an extending reporting period (tail coverage) for one year.

**Additional Insured Endorsement Language**

"Irvine Unified School District, its Board of Trustees, officers, agents, employees, and volunteers are named as additionally insured on this policy pursuant to written contract, agreement, or memorandum of understanding. Such insurance as is afforded by this policy shall be primary, and any insurance carried by District shall be excess and noncontributory."

Additional Insured Endorsements are required to accompany Certificates of Insurance. Certificate of Insurance shall provide thirty (30) day prior written notice of cancellation.

See sample certificate on the Irvine Unified School District website at [www.iusd.org](http://www.iusd.org).

**Additional Required Documents**

Certificates of Insurance must be accompanied by a list of all excluded coverages under the general liability and excess/umbrella liability policies. The exclusion policy document section may be emailed or faxed to Risk Management & Insurance. The general liability and excess/umbrella liability documents must list the corresponding policy numbers referenced on the Certificate of Insurance.

Questions may be directed to Risk Management & Insurance at [Insurance@iusd.org](mailto:Insurance@iusd.org).

Email: [Insurance@iusd.org](mailto:Insurance@iusd.org)

Fax: (949) 936-5019

Revised: September 2016

## **APPENDIX A**

### **Specifications**



## **CONCRETE CURBS, GUTTERS, WALKS, & PAVEMENT**

### **PART 1 – GENERAL**

#### **1.01 WORK SPECIFIED IN THIS SECTION**

- A. Furnish all materials, equipment, and labor required to complete the work of this section as indicated on the drawings and as specified herein.

### **PART 2 – PRODUCTS**

#### **2.01 MATERIALS**

- A. Cement: ASTM C150, Type I: Type II, low alkali, may be required dependent upon the aggregate source.

#### **2.02 QUALITY CONTROL**

- A. Aggregates: ASTM C33. Obtain from an approved source to insure uniform quality and grading; deliver so that moisture content variations will not decrease production of reasonable uniform concrete. Do not use aggregates that are reactive with alkalis.

#### **2.03 STRENGTHS**

- A. Concrete shall develop a minimum ultimate compressive strength of 2500 psi. For testing requirements see General Conditions.

#### **2.04 REINFORCING**

- A. Reinforcing Steel: Bars, ASTM 615, Grades 40 and 60; wire, ASTM A82; wire mesh, ASTM A185. Reinforcing steel shall be used only where called for.

### **PART 3 – EXECUTION**

#### **3.01 CURING**

- A. Concrete slabs and paving shall be properly cured and protected against damage and defacement of any nature during construction operations. If weather is hot or surface has dried out, spray surface with fine mist of water starting not later than two hours after final troweling. Surface of finish shall be kept continuously wet for at least ten days. Wetting is considered emergency work and shall be performed on weekends and holidays if necessary.

- B. In lieu of water curing, within 24 hours after finishing, the concrete may be cured with a clear

liquid curing compound such as "Sealtight #1100" by W.R. Meadows or equal applied in accordance with manufacturer's recommendations.

### 3.02 EXPANSION JOINTS

- A. Curbs and gutters - 20 ft. O.C. maximum - "Cellotex" Flexcell" 1/2 inch thick.
- B. Walks and slabs -(when indicated on the drawing only) 1/4 inch thick "New 300" Homex joint filler by SCA Construction Supply. Tool with 1/8 inch radius or carpet edge. Seal with "DARASEAL-U" traffic grade, two-component polyurethane sealant by W.R. Grace & Co. Products. Color shall be "Natural Grey."

### 3.03 CONTROL JOINTS

- A. Control joints for concrete walks and exterior concrete pavement are indicated on the courtyard plan. Refer to cold and score joint detail on architectural sheets.

### 3.04 FINISH

- A. Walks and pavement: All onsite concrete paving shall have a medium broom finish on all surfaces less than 6% and a heavy broom finish on all surfaces greater than 6%.
- B. Gutters: Light broom finish with 3-inch wide steel trowel finish at flow-lines.
- C. Curbs: Steel trowel finish.
- D. Ramps, stair treads and landings: Heavy broom finish/perpendicular to path of travel or slip resistant. Provide at all .tread nosing. 2" wide, slip resistant white line shall be painted adjacent to nose and shall extend the entire width of each tread. 1" back from nosing.
- E. On-site drive aprons: Heavy broom finish.

### 3.05 OFF-SITE CONCRETE WORK

- A. Concrete driveway aprons, street sidewalks, curbs, and gutters, etc., indicated to be constructed outside of property lines shall conform to the standards and specifications of the public agency having jurisdiction and shall be subject to inspection by its representative The Contractor shall obtain and pay for all necessary permits. The Owner will pay for all inspection fees.

## **GENERAL CONTRACTOR**

### **SECTION I – STEEL REINFORCEMENT**

#### **1. General**

- 1.01 REFERENCE: Requirements in Addenda, and Conditions collectively apply to this work.
- 1.02 DESCRIPTION: Principal Work Items Are:
- A. Rebar.
  - B. Welded wire mesh.
  - C. Accessories.
  - D. Work furnished but installed by another section.
    - 1. Fabricated rebar for masonry.
    - 2. Fabricated rebar for site drainage concrete structures.
- 1.03 SUBSTITUTIONS: Only written approval of District will permit substitutions for materials specified.
- 1.04 QUALITY ASSURANCE:
- A. Requirements of Regulatory Agencies:
    - 1. Codes: Conform to Title 24, CCR and UBC.
    - 2. Off-site Work: Conform to local governing agency requirements.
  - B. Reference Standards: Concrete Reinforcing Steel Institute (CRSI) Manual of Standard Practice.
- 1.05 SUBMITTALS:
- A. Mill certificates.
  - B. Certificate for Off-site Work: Provide for all off-site work.
- 1.06 PRODUCT DELIVERY, STORAGE AND HANDLING:
- A. Deliver reinforcement to project site in bundles marked with metal tags indicating bar size, length, configuration and building location.
  - B. Handle and store materials to prevent injury or unwanted bends.
  - C. Store materials on blocking to prevent contact with ground. Do not store materials in water puddles.
- 1.07 JOB CONDITIONS: Sequencing, Scheduling: Coordinate work with trenching for foundations, concrete forming and placement. Schedule delivery of rebar for masonry with respective sections.

#### **2. Products**

- 2.01 MATERIALS:

- A. General: Conform to applicable Codes; refer to Title 24, Section 2-2603(f) in particular.
- B. Rebar: UBC Standard 26-4, which is based on ASTM A-615; deformed; grade 60 typical, other stresses where noted.
- C. Welded Wire Mesh: UBC Standard 26-6, which is based on ASTM A-185; 75,000 psi tensile strength for 10 gauge and larger wire, 70,000 psi tensile strength for 11 gauge and smaller wire. Flat sheets only.
- D. Tie Wire: UBC Standard 24-15, which is based on ASTM A-82; annealed steel, 16 gauge minimum.
- E. Accessories:
  - 1. General: CRSI Standards for chairs, spacers, supports and other accessories.
  - 2. Support Blocks for Rebar and Welded Wire Mesh: Dense precast concrete.

#### 2.02 FABRICATION OF REBAR:

- A. General: Per CRSI Standards.
- B. Fabricate to lengths and shapes required.
  - 1. Bends: Bend cold around a pin; minimum diameter shall conform to Title 24, Section 2-2607(b) and Table 2-26C.
  - 2. Do not bend or straighten bars in a manner which will injure material.

### 3. Execution

#### 3.01 INSTALLATION:

- A. Scope:
  - 1. Install all steel reinforcement for concrete work.
  - 2. Install all dowels in concrete, to match locations of masonry wall reinforcement.
- B. General:
  - 1. Conform to Codes.
  - 2. Do not use rebar which has bends or kinks other than those required.
  - 3. Do not heat, bend, cut, or alter rebar at Project site without concurrence of District.
- C. Placement; Rebar:
  - 1. Accurately position rebar; securely anchor against displacement.
  - 2. Support rebar above earth or previous concrete pour on concrete support blocks.
  - 3. Support rebar above forms on vinyl coated metal chairs, plastic chairs or stools. Anchor securely to maintain required clearances from form faces.
  - 4. At columns or piers, do not drive nails into outside forms to support rebar, nor use any other supporting device which will contact outside form.
- D. Spacing; Rebar: Maintain following minimum clear distances between bars, or greater distances where required.
  - 1. All Cases: 1-1/2" minimum.
  - 2. Parallel Bars (except at splices): 1-1/2 times nominal diameter.
- E. Clearances; Rebar: Maintain following minimum clear distances to provide concrete coverage for protection of rebar, or greater distances where required.
  - 1. Footing surfaces poured directly on earth: 3"
  - 2. Walls against earth, but placed in forms: 2"

3. Walls, formed (except [2] above): 1-1/2"
  4. Columns, 2" to main steel.
- F. Splices; Rebar:
1. Splice only at approved locations.
  2. Lap Splices: Wire tie securely together.
    - a. Use typically for splices, corners, intersections.
    - b. Minimum lap distance, unless otherwise required: Concrete: 30 bar diameters, but not less than 24" in any case.
  3. Other Splice Methods: Only with specific Architect approval.
  4. Separate splices Code required distances.
- G. Welded Wire Mesh:
1. Install in longest practicable length.
  2. Lap adjoining pieces one full mesh minimum, and tie splices with 16 gauge wire.
  3. Offset laps in adjacent widths to prevent continuous laps.
  4. Where mesh is 12" x 12" or greater, support on precast concrete blocks spaced 3', maximum, o.c. each way.
- 3.02 ADJUSTMENT AND CLEANING:  
Just prior to concrete placement, clean reinforcement free of coatings, rust, scale, that will reduce or destroy bond. Reinforcement appreciably reduced in section by cleaning shall be replaced as directed by District. Reposition any misaligned reinforcement.

END OF SECTION

## SECTION II - CAST-IN-PLACE CONCRETE

### 1. General

- 1.01 REFERENCE:  
Requirements in Addenda, Alternates, and Conditions collectively apply to this work.
- 1.02 DESCRIPTION: Principle Work Items Are:
- A. Concrete Work:
    - 1. Rough concrete.
    - 2. Finish concrete.
    - 3. Specially finished concrete.
    - 4. Bases for light poles.
    - 5. School name sign with cast-in letters.
    - 6. Grouting at folding panel partition sills.
  - B. Formwork.
  - C. Curing and protection
  - D. Plastic membrane.
  - E. Off-site work: Sidewalks, driveways, curbs and gutters.
  - F. Work installed but furnished by another Section:
    - 1. Setting rough hardware and other embedded items.
    - 2. Setting grates and frames for areaways.
- 1.03 SUBSTITUTIONS: Only written approval of the District will permit substitutions for materials specified.
- 1.04 QUALITY ASSURANCE:
- A. Design criteria; formwork: Contractor shall be solely responsible for all formwork and Contractor shall:
    - 1. Design, construct and maintain formwork to safely support all loads.
    - 2. Obtain Governing Agency approval, when such is required.
  - B. Testing Agency:
    - 1. On-site work: District designated testing laboratory.
    - 2. Off-site work: Governing Agency approved testing laboratory.
  - C. Requirements of Regulatory Agencies:
    - 1. Codes: Conform to Titles 21 and 24 of the CAR and conform to U.C.
    - 2. Off-site work:
      - a. Conform to Local Governing Agency requirements.
      - b. Obtain and pay for all permits, licenses and fees.
      - c. Arrange for all tests and inspections.
  - D. Tests and Inspections; General: Refer to Section 01400.
  - E. Allowable Tolerances for Concrete Surface Smoothness: 1/8" maximum permissible variation from a true plane measured from a 10' straight edge placed anywhere on the surface, non-cumulative.
  - F. Job Mock-Ups (if required by District):
    - 1. General:

- a. Make samples on-site; revise as required; obtain District's approval, 10 days prior to casting finished work.
      - b. Finished work to match approved samples.
      - c. Approved sample may be incorporated into the work.
    2. Specially Finished Concrete: Flatwork:
      - a. Sample size: 20 SF minimum.
      - b. Required for following finishes: Salt.
    3. Specially Finished Concrete; School Name Sign:
      - a. Sample size: 2 SF minimum wall area.
      - b. Required for following finishes: Sandblasted.
  - G. Source Quality Control:
    1. Testing laboratory shall provide continuous inspection at concrete batch plant for all structural concrete, defined as follows:
      - a. Footings, foundation walls, floor slabs-on-grade, exterior reinforced slabs.
      - b. Walls.
    2. Furnish Weighmaster's Certificates for all concrete.
- 1.05 SUBMITTALS:
- A. Shop Drawings for Cast-In Letters: Full-size template layout of wording for school name sign.
  - B. Concrete Design Mix: By testing laboratory.
  - C. Test Reports: Source and Field Quality Control tests.
  - D. Certificates:
    1. Weighmaster's Certificates: Per Office of the State Architect requirements.
    2. Certificate For Off-site Work: Provide for all off-site work.
- 1.06 PRODUCT DELIVERY, STORAGE AND HANDLING:
- A. Storage; Concrete Materials:
    1. Cement: Store in weather tight enclosures and protect against dampness, contamination and warehouse set.
    2. Aggregates
      - a. Stock pile to prevent excessive segregation or contamination with other materials or other sizes of aggregates.
      - b. Use only one supply source for each aggregate stock pile.
    3. Admixtures:
      - a. Store to prevent contamination, evaporation or damage.
      - b. Protect liquid admixtures from freezing or harmful temperature ranges.
      - c. Agitate emulsions prior to use.
  - B. Delivery; Ready-Mixed Concrete: Conform to title 24, Section 2-2605(b) (which refers to U.C., Standard 26-13).
  - C. Formwork Materials:
    1. On delivery to job-site, place materials in area protected from weather.
    2. Store materials above ground on framework or blocking and cover with protective waterproof covering providing for adequate air circulation or ventilation.
    3. Handle materials to prevent damage.

1.07 **JOB CONDITIONS:**

A. Environmental Requirements: Allowable Concrete Temperatures:

1. Cold Weather: When depositing concrete in freezing or near-freezing weather, concrete mix temperature shall be between 50° and 90°F. when cement is added. Maintain a concrete temperature of 50°F. minimum for 72 hours minimum after placing or until concrete has thoroughly hardened. When necessary, heat concrete materials before mixing. Take necessary precautions to protect transit-mix concrete.
2. Hot Weather: 90° F. maximum.

B. Protection:

1. Do not place concrete during rain, sleet, or snow unless protection is provided.
2. After placement, protect from injury by elements, traffic, construction operations and other causes.

C. Sequencing, Scheduling: Coordinate work with earthwork, trenching for foundations, underground utilities, plumbing, electrical, mechanical, Section furnishing imbedded items, steel reinforcement and related work of other Sections.

**2. Products**

2.01 **MATERIALS; GENERAL:** Conform to Codes and additional requirements stated herein.

2.02 **BASIC CONCRETE MATERIALS:**

A. Portland Cement:

1. Type I or 11; per Title 24, Section 2-2603(c), which refers to U.C., Standard 26-1 and ASTM C150.
2. Use tested cement only. Use same cement brand for all exposed work.

B. Water: Clean, fresh, free of injurious amounts of minerals, organic, substances, salts, acids or alkali.

C. Aggregates:

1. General: Per Title 24, Section 2-2603(d), and U.C., Standards.
2. Hardrock Aggregates: Per U.C. Standard 26-2 (which refers to ASTM C33).
  - a. Fine: Sand well graded from coarse to fine.
  - b. Coarse: Uniformly graded from 1/4" to maximum permissible size. Maximum size per Title 24, Section 2-2603(d) (3); but not to exceed 1" in any case.
3. Lightweight concrete: Per U.C. Standard 26-3 (which refers to ASTM Standard C330-80).

2.03 **MATERIALS; CONCRETE ADDITIVES:** Admixtures:

A. General: Inclusion in concrete mix is at the Contractor's option and expense.

B. Types:

1. Conform to Title 24, Section 2-2603(9), which refers to U.C., 26-9 (which is based on ASTM C260, C494, C618). Admixtures shall increase workability and reduce water demand.
2. Acceptable Products: Floor slabs-on-grade: Red Label or Anti-Hydro.



2.04 MATERIALS; CONCRETE SURFACE TREATMENTS:

A. Liquid Curing Compounds:

1. General: Conform to ASTM C309.
2. Acceptable Manufacturers: Hunt Process Co., Burke Co., Scofield Sonneborn.
3. Black, Permanent Type (For areas to receive Resilient Flooring or Car pet): Hunt Black, as a standard of quality.
4. Clear, Oxidizing Type (For areas to be exposed, interior or exterior): Hunt Clear No. ARB as a standard of quality.

B. Floor Hardeners: Color Hardeners; Dry shake:

1. Color: Natural gray.
2. Acceptable manufacturers and products:
  - a. Scofield Co., Lithochrome; as a standard of quality.
  - b. Master Builders, Colorcon.
  - c. Sonneborn, Harcol.

C. Abrasive Grains:

1. Type: 60% minimum aluminum oxide abrasive, ceramically bonded to vitrification, neutral color, homogeneous, rustproof; crushed and graded from 1/32" to all passing 1/4" screen.
2. Acceptable Manufacturers and Products:
  - a. Norton Co., Alundum Fine DF; as a standard of quality.
  - b. Scofield Co., Lithochrome Abrasive Grains.

2.05 MATERIALS: CONCRETE JOINTS:

A. Metal Joint Form/Screed:

1. Type: 24 gauge galvanized formed steel, tongue and groove design, 7/8" diameter rebar knockouts at 6" on center; depth equal to slab depth. Complete system with form/screed, stakes, splice plates, clips and all accessories.
2. Acceptable manufacturers and products:
  - a. Burke, Keyed Kold; as a standard of quality.
  - b. Greenstreak, No. 500 Series, Joint Screed.
  - c. Heckmann, No. 95, Tongue and Groove Joint.
  - d. Jahn, Screed Key Joint.

B. Zip-top Control Joints:

1. Type: Extruded one-piece plastic T shape, removable zip-off top.
2. Acceptable manufacturer, Zipcap.

C. Expansion Joints; Asphalt Impregnated Fiber:

1. Type: Cane fiber, p e-formed, waterproof asphalt impregnated; 1/2" thick x slab depth; per AASHO M213.
2. Acceptable Manufacturers and Products:
  - a. Burke Co., Fiber Expansion Joint.
  - b. Sonneborn, Sonoflex.

2.06 MATERIALS; SPECIALLY FINISHED FLATWORK: Rock Salt: Commercial coarse granular type, (similar to that used in water softening systems) sized from 1/4" to 3/8", with 65% 3/8" in size.

2.07 MATERIALS; WOOD FORMWORK:

- A. Grade Marks and Rules For Lumber and Plywood: Per Section 06100, Rough Carpentry.
- B. Framing Lumber; General: Douglas Fir; Standard Grade Light Framing or better.
- C. Boards For Unexposed Concrete and Basic Forms: Douglas Fir, S4S; Standard Grade or better.
- D. Plywood:
  - 1. For unexposed concrete and basic forms: Douglas Fire; Exterior grade C-C or better.
  - 2. For exposed concrete: Douglas Fir Plyform, Exterior class 1; B-B wood face or high density overlay sheet (HDO).
- E. Form Ties; Typical:
  - 1. Type: Snap-ties, carbon steel, 1/4" maximum diameter, 1" minimum break back, 5,000 lb. minimum strength; adjustable or accurately sized.
  - 2. Acceptable manufacturers and products:
    - a. Burke, Penta-Tie; as a standard of quality.
    - b. Concrete Tie, Contac.
- F. Form Coatings and Release Agents: Types:
  - 1. Per manufacturer's recommendations, suitable for type of form materials and finished concrete surface.
  - 2. Materials shall not stain or change color of exposed concrete.
  - 3. Materials shall be compatible with finishes to concrete.
- G. Chamfers and Control Joints:
  - 1. General: Wood or plastic, saw kerf backs, 15 taper sides, width or least equal to depth, configurations as required.
  - 2. Chamfers: 3/4" minimum width.

2.08 MATERIALS; ACCESSORIES AND MISCELLANEOUS:

- A. Leveling Filler For Floor Slabs:
  - 1. Type: Liquid latex compound; and filler powder.
  - 2. Acceptable manufacturers and products:
    - a. Flintkote, Latex Underlayment Binder and Powder.
    - b. Dowman Products, Fixallatex latex underlayment.
    - c. Webtex No. 660 Latex Underlayment.
- B. Nailing Blocks and Other Embedded Wood: Pressure-treated Douglas Fir, per Section 06100.
- C. Plastic Membrane At Slabs:
  - 1. Type: Polyethylene film, 8 mils thick minimum; with manufacturer's recommended self-adhesive joint tape.
  - 2. Acceptable manufacturers and products: Visqueen, Moistop, Durathene.
- D. Sand for Sandblasting: Hard, sharp, quartz sand.
- E. Non-Shrink Grout Por-Rok by Hallemite Co; Masterflow No. 713 Grout by Master Builders; Lithochrome, TRU Grade, by Scofield.

2.09 MIXES; CONCRETE:

- A. Mix Proportioning:

1. General:
    - a. Designed Mix, per Title 24, Section 2-2604(c), by Method B; for all concrete.
    - b. Mix design by designated Testing Laboratory.
    - c. Design shall include all admixtures and/or additives, if any. Use as approved by the Office of the State Architect.
    - d. Do not add salt, chemicals, or other materials to mix to prevent freezing.
  2. Strengths, Proportions and Criteria: 2,500 psi Concrete: Typical for all locations; except where higher strengths are indicated.
    - a. Strength: 2,500 psi and 28 days; 1,500 psi at 7 days.
    - b. Cement content, minimum 5-1/4 sacks (94#) cy.
    - c. Slump maximum: 4".
- B. Mixing:
1. General: Per Title 24, Section 2-2605 and U.C., Standard 26-13 (which refers to ASTM C94).
  2. Batch Mixed: Use ASTM C94 batch mixer; or capacity to handle one or more full sack batches. No split-sack batches.
  3. Transit Mixed: Per U.C., Standard 26-13.
  4. Mix concrete only in quantities necessary for immediate use.
  5. Do not retemper concrete.
  6. Discharge all wash water from mixer before reloading.
  7. Include additives and admixtures.
- 2.10 MIXES; DRYPACK:
- A. Mix Proportions: One part cement, 1 -1/2 parts sand (fine aggregate).
  - B. Mixing: With sufficient water to make a stiff mixture which can be molded by hand into a sphere.
- 2.11 MIXES; GROUT MIX FOR SACKED FINISH:
- A. Mix Proportions: One part cement, 1-1/2 parts fine sifted sand.
  - B. Mixing: With sufficient water, to the consistency of thick paint.

### **3. Execution**

- 3.01 INSPECTION:
- A. Examine excavations for foundations, footings, structures and examine earthwork operations and subgrade for defects that will adversely affect the execution and quality of work.
  - B. Do not start work until unsatisfactory conditions are corrected.
- 3.02 PREPARATION:
- A. Layout: Accurately layout work to properly position ail elements to lines and levels.
  - B. Joining To Previous Pours or Existing Work: Sandblast, roughen and clean existing joining concrete and rebar surfaces to provide a proper bond to new work.
- 3.03 WOOD FORMWORK:
- A. Scope:

1. General: All concrete shall be cast-in forms.
  2. Footings: When specifically approved by Architect/Engineer and the Division of State Architect, earth banks may be used as forms in lieu of wood forms.
- B. Form Face Types:
1. Unexposed Concrete: Plywood or horizontal boards.
  2. Exposed Concrete:
    - a. General: All new materials, or materials reconditioned to like new.
    - b. Typical Work: Plywood panels, 4' x 8' typical size. Layout symmetrically, long diameter vertical; panels stacked; all joints aligned, level, plumb, and tight.
- C. General Construction:
1. Forms shall be substantial, unyielding, true to line and level; sufficiently tight to prevent leakage of mortar; adequately tied and braced; and conform exactly to dimensions of finish concrete.
  2. Forms shall provide adequate work clearances, temporary access openings necessary for concrete placement, provisions for attachment to previous work; and provide for stripping without injury to concrete work.
  3. Cleanouts: Provide continuous cleanouts on one side at bottom of vertical work (such as walls), and other openings as necessary to facilitate cleaning and inspection of the work.
- D. Fabrication:
1. Nail board and/or plywood form faces securely to studs. Space studs to adequately support form faces and prevent bulging. Provide stud or solid backing at all joints.
  2. Install chamfer strips at all exposed corners and edges.
  3. Securely fasten chamfers, control joints and other detail work.
- E. Erection:
1. General: Erect formwork plumb and level; double wales; adequately brace, shore and support; set so finished concrete surfaces will drain.
  2. Ties and Spreaders:
    - a. General: Position to securely anchor forms; maintain accurate wall dimensions, true surfaces and prevent bulging.
    - b. Exposed Concrete: Position in similar symmetrical patterns.
  3. Footings and Foundation Walls: Form both sides; secure to stakes.
  4. Walls: Form both sides; set so tops of exposed work will be a straight, level line.
- F. Form Coatings and Release Agents: Apply, per manufacturer's recommendations, to evenly coat all contact surfaces.
- 3.04 INSTALLATION; EMBEDDED ITEMS:
- A. Install per Title 24, Section 2-2606 (c) and U.C., 2606(c).
  - B. Place accurately; anchor securely to prevent displacement.
  - C. No wood to be permanently embedded in concrete, except where indicated.
  - D. Coordinate, notify, provide access for other Sections to set their required work.
- 3.05 INSTALLATION; GRATES AND FRAMES FOR AREAWAYS: Install accurately, level, at proper elevations, securely anchored, and with ail fastenings in place.

3.06 INSTALLATION; SCREEDS FOR SLABS, WALKS AND FLAT WORK:

A. General:

1. Set and securely support screeds accurately to lines, levels and grades required for finished work.
2. Where membranes occur, supports shall not puncture membranes.
3. Spacing: 8'-0" on center typically; closer intervals where construction conditions require.

B. Permanent Metal Joint Form/Screeds:

1. Scope: Install in all exterior slabs, walks, paving and flatwork.
2. Spacing/Location: 20'-0" on center maximum each way; all points where concrete changes direction; and where indicated.
3. Installation: Burke Keyed Kold system; as a standard of quality.
  - a. Stakes: Space 2'-0" on center typical; and 6" maximum from ends of runs.
  - b. Screeds: Hang screeds on stakes, crimp top leg into hole in stake, clip bottom leg to stake, butt joints and install splice plates.
  - c. Coating: Oil screeds prior to concrete placement.
  - d. When concrete pour is against one side only, bend knock-out tabs into pour at 45° approximate.

3.07 INSTALLATION; PLASTIC MEMBRANE:

A. Scope: Install under all interior floor slabs on-grade.

B. Installation:

1. General: Place over prepared 2" sand over compacted earth, cover with 2" sand, prior to steel reinforcement placement. Use as large sheets as practicable. Cut and fit neatly around all penetrations.
2. Joints: Lab 6" typical; lap floor sheets 2'-0" minimum over footing sheets.
3. Taping: Spot tape joints to hold sheets in place. Tape seal all punctures and around all penetrations and all lap joints.

3.08 PREPARATION; CONSTRUCTION JOINTS:

A. General:

1. Comply with Title 24, Section 2-2606(d) and U.C., 2606(d).
2. Locate joints where they will least impair strength of structures.
3. For joints at locations other than those indicated, obtain Architect/Engineer or District approval.

B. Preparation:

1. Clean and roughen entire joint face to remove entire surface and expose clean aggregate solidly embedded in mortar matrix by one of the following methods.
  - a. Sandblast or chip, not earlier than five days after initial pour.
  - b. Hose wash clean between two and four hours after concrete is placed. Remove all wash water, laitance and debris.
2. Vertical Joints: Wet and flush with neat cement grout, just prior to concrete placement.
3. Horizontal Joints: Wet and deposit 2" to 6" layer of specified modified concrete mix, prior to placing regular mix.

- 3.09 PREPARATION; SLABS-ON-GRADE: Tamp sand sub-base to a firm unyielding surface.
- 3.10 CONCRETE PLACEMENT:
- A. General: Comply with Title 24, Section 2-2605 and U.C., 2605.
- B. Preparation and Inspection Prior to Concrete Placement:
1. Preparation: Do not place concrete until:
    - a. Footing excavations are cleaned and dry.
    - b. Steel reinforcement is correctly positioned, securely anchored and cleaned.
    - c. Forms are cleaned, coated; and ties are tightened.
    - d. Embedded items are positioned and anchored.
    - e. Construction joints are cleaned and prepared.
    - f. Subgrade is prepared and moistened.
    - g. All preparations for a pour are completed.
    - h. Work has been inspected.
  2. Inspection: All formwork, steel reinforcement, footing excavations and preparation work (as stated in Paragraph No. 1) to be inspected and approved by Architect/Engineer or District, prior to pouring any concrete.
- C. Placement:
1. Convey concrete from mixer to final position by method which will prevent separation or loss of material and cause minimum handling.
  2. Deposit concrete in continuous operation will panel or section is completed.
  3. Regulate rate of placement so concrete remains plastic and flows into position.
  4. Keep tops of vertical lifts approximate level during placement.
  5. Maximum permissible free-fall for concrete is 3'. Use elephant trunks or other approved means necessary to meet this limitation.
  6. Maximum permissible thickness of concrete layers is 2'.
  7. Where reinforcement is congested or consolidation is difficult, specified modified concrete mix may be used in a 2" to 6" layer.
  8. Special conveyance and placement methods may be used with prior approval of Architect/Engineer or District.
  9. Do not use partially hardened or contaminated concrete; do not retemper concrete; or do not use concrete which has been remixed after initial set.
- D. Consolidation:
1. Use mechanical vibrating equipment. Supplement with hand rodding, spading and tamping.
  2. Vertically insert and remove hand-held vibrators.
  3. Work concrete thoroughly around reinforcement, embedded items and into all parts of forms.
  4. Consolidate to a dense, uniform mass without voids, rock pockets, or entrapped air. Consolidate each layer.
- E. Slabs, Walks and Flatworm:
1. Lift reinforcement as placement progresses to proper position in slab.
  2. Tamp and screed to required lines and levels.
  3. Depress coarse aggregate with grille-blade tamper.

### 3.1 1 FINISHING FLATWORK; TYPICAL:

- A. Scope: Finish all flatwork as specified herein.
- B. Interior Slabs:
  - 1. General:
    - a. Monolithically finish all slabs.
    - b. Do not dust with dry cement to remove water.
  - 2. Floating:
    - a. Power float upon disappearance of water shown.
    - b. Hand float areas inaccessible to power float.
  - 3. Trowel Finishing:
    - a. Areas depressed for ceramic and quarry tile: Further finishing is not required.
    - b. Areas to receive carpet and resilient floor coverings: Power trowel to a dense, smooth, even surface, until no more excess water may be brought to surface.
    - c. Exposed concrete areas: Gray color hardened.
      - i. Just prior to floating, evenly apply 20 lbs. hardener per 100 SF.
      - ii. After floating, spot touch-up uneven areas; then evenly apply ten lbs. hardener per 100 SF.
      - iii. First Troweling: Power trowel per Paragraph B above.
      - iv. Hand steel trowel (causing trowel to ring) to a smooth, slick, burnished surface, free of defects and blemishes.
- C. Exterior Flatwork (Slabs, Walks, Paving and Similar Work):
  - 1. General:
    - a. In indicated areas, finish concrete as specified herein, in lieu of typical finishes.
    - b. All work to match approved samples.
    - c. The Contractor is to limit pour areas and provide sufficient ratio of finishers to produce specified finishes.
  - 2. Sweated Finish; Typical:
    - a. Two steel troweling IS, while concrete is still green.
    - b. Non-slip sweated finish with regular light trowel marks in an approximately 2' circular arc pattern.
  - 3. Salt Finish; where Indicated:
    - a. Preparation: Screed and float. Steel trowel smooth and even in circular arc pattern, free of blemishes and ridges.
    - b. Salt Application:
      - i. While concrete is still plastic evenly and uniformly seed surface at 10 lbs. minimum per 100 SF; 3" maximum between pockmarks any where on surface.
      - ii. Press, roll or trowel salt grains to embed them flush with concrete surface; do not shatter salt grains.
      - iii. After concrete sets, completely dissolve and wash salt away from planting areas.
  - 4. Marking:
    - a. Type; Typical: V-groove radius tool.
    - b. Patterns: Follow indicated patterns; where not indicated, mark as follows:
      - i. Walks: Into squares, equal to walk width.



- ii. All areas 8' or wider: Into approximate squares, 8' maximum diameter.
    - 5. Tooling: Radius tool all exposed edges, edges adjacent to all permanent wood headers and edges at each side of all metal joint screeds.
  - D. Abrasive Surface Treatment:
    - 1. Scope: Apply to all exterior and interior exposed concrete steps and ramps and where indicated: Ramp defined as surface sloping ½" or steeper.
    - 2. Application: Apply evenly at 25 lbs. per 100 SF just prior to final troweling  
Tamp and trowel to securely embed, but not cover abrasive.
- 3.12 FLATWORK CONTROL JOINTS:
- A. General: Conform to Title 24, Section 2-2606(d).
  - B. Interior Slabs-on-Grade:
    - 1. General: Create construction joints to divide slabs into 400 SF maximum approximate rectangular shapes, by any of the following methods.
      - a. Alternate pours, checkerboard pattern.
      - b. Saw cutting within 12 hours from time of pour.
      - c. Install Zip-Top control joints concurrently with tamping and floating work. Using sawing motion, push straight-edge into concrete to form groove. Insert Zip-Top control joint into groove, using sawing motion, until joint top is flush with concrete surface. When concrete sets sufficiently, pull-off removable top flange.
    - 2. Location: Locate joints typically to occur under partitions, avoid exposed concrete floor areas; align with structural features, points where slab changes configuration or direction and points where stresses localize.
  - C. Exterior Flatwork (Walks, Paving and Similar Work); General: Construction joints formed by permanent Metal Joint Form/Screeds per Paragraph 3.06 B.
- 3.13 FORMWORK REMOVAL:
- A. General: Do not remove or disturb forms, shoring or bracing until concrete has hardened sufficiently to permit safe removal, support all imposed loads including its own weight, nor in any case until the following minimum times have elapsed:
    - 1. Foundation Walls: Three days.
    - 2. Slabs-On-Grade: Three days.
    - 3. Walls: Three days.
  - B. Ties: Remove or snap-off ties, spreaders, tie rods, and other devices so no metal is left within 1" of concrete face.
  - C. Exposed Concrete Work: Carefully remove formwork and detail strips so surfaces, corners, edges, details, and all features will be true, level, sharp, unbroken, unmarred or damaged in any way.
- 3.14 PROTECTION AND CURING OF CONCRETE:
- A. Protection: Protect all work from injury and defacement of any nature during construction operations.
  - B. Curing:
    - 1. General:
      - a. Keep concrete surfaces wet until curing medium is applied.



- b. Cure drypack same as concrete.
  2. Walls, Mass and Reinforced Concrete:
    - a. Scope: Maintain in a thoroughly wet condition all forms containing concrete, top of concrete between forms, all exposed concrete surfaces after removal of forms.
    - b. Time Period: Wet continuously each day for 10 consecutive days, including Saturdays, Sundays and holidays.
  3. Flatwork:
    - a. Scope: Apply specified liquid curing compounds to all interior floor slabs, and all exterior flatwork (slabs, walks, paving, and similar work).
    - b. Application: Apply uniform, continuous, tightly adhered film, free from pinholes or defects at rate of 1 gallon per 250 SF.
- 3.15 FINISHING WALLS AND VERTICAL CONCRETE SURFACES; TYPICAL:
  - A. Scope: Finish all walls and vertical concrete surfaces as specified herein, except for school name sign.
  - B. Exposed Concrete At Tops of Forms:
    1. Strike concrete smooth and level.
    2. Float and/or trowel to texture comparable to formed surfaces.
  - C. Preparation, Formed Surfaces:
    1. Remove fins and irregularities while concrete is green.
    2. Tie Holes: Fill full and flush with compacted drypack.
    3. Surface Defects:
      - a. Cut out blemished and defective areas as directed by the Architect.
      - b. Patch flush with drypack, typically, or as directed by the Architect.
  - D. Cleaning:
    1. Exposed Surfaces:
      - a. Remove form coatings, bond breakers and other surface coatings.
      - b. Scrub formed surfaces with solution of 1-1/2 lbs. caustic soda per 1 gallon water.
      - c. Scrub smooth wood or waste mold areas with 20% muriatic or hydrochloric acid solution.
      - d. Wash surfaces clean with clear water, immediately after scrubbing.
      - e. If above methods fail to remove all substances, lightly sandblast surfaces clean as directed by the Architect.
    2. Surfaces With Finish Materials Applied Directly to Concrete: Clean as stated for Exposed Surfaces, except where uncleaned surface will not affect application, bond, performance or appearance of finish materials.
  - E. Sacked Finish For All Exposed Concrete:
    1. General: Schedule work to complete entire panel, element or area in one continuous operation.
    2. Application:
      - a. Wet surface to control suction of water from grout.
      - b. Apply grout mix; uniformly spread and scour to fill depressions.
      - c. While still plastic, sponge rubber float finish surface and remove excess grout.

3. Sacking: Allow surface to dry, but not completely harden; then rub vigorously with clean dry burlap to remove loose excess material. Finished surface to have a smooth slick burnished finish (similar to a steel trowel finish) which is free of defects and blemishes.
- 3.16 PREPARATION OF HORIZONTAL CONCRETE SURFACES TO RECEIVE MASONRY WALLS: Prepare and roughen as specified for horizontal concrete construction joints in Paragraph 3.08 B1.
- 3.17 SCHOOL NAME SIGN; CAST-IN LETTERS:
- A. Accurately set letters in place; space to match approved Shop Drawings. Coat with bond breaker. After concrete hardens, carefully remove wood letters to leave sharp, clean recesses in the concrete.
  - B. Sandblast Finish:
    1. General:
      - a. Scope: Heavily and uniformly sandblast to expose coarse aggregate.
      - b. All work to match approved samples.
      - c. Complete entire side in one continuous operation.
    2. Preparation: Per Paragraphs 3.15 B and C.
    3. Sandblasting:
      - a. Wet or dry processes, as permitted by Local Governing Ordinances.
      - b. Control dust from drifting to adjacent areas.
      - c. Where wet process is used, build dams and otherwise control and direct flow of run-off water.
    4. Cleaning:
      - a. Wash down all blasted surfaces with clear water to remove dust, sand and leave them clean.
      - b. Remove all blasting sand and debris.
- 3.18 FIELD QUALITY CONTROL:
- A. General: Refer to Section 01400, Testing and Inspection.
  - B. Inspections:
    1. Steel reinforcement.
    2. Structural concrete.
  - C. Tests:
    1. Concrete slump.
    2. Making concrete compression test cylinders.
    3. Core tests of defective work.
- 3.19 ADJUSTMENT AND CLEANING:
- A. Correction of Defective Work:
    1. General: Work not conforming to Contract requirements shall be removed and replaced; except where patching or other remedial work is specifically permitted by the District. The Contractor shall bear all costs of correction of defective work.
      - a. Surface patching materials and methods shall be as approved by the District.

- b. Structural concrete replacement, strengthening, and/or repair methods and materials shall be as approved by Architect/Engineer and the Division of State Architect.
  - 2. Filling and Leveling Slab Surfaces to Receive Resilient Flooring or Carpet:
    - a. High Spots: Remove, hone or power grind to required levels.
    - b. Low Sports: Fill to required levels with specified Leveling Filler, mixed and applied manufacturer's recommendations.
- B. Cleaning: Clean exposed surfaces just prior to acceptance.

END OF SECTION

## SECTION III - CHEMICAL-RESISTANT SEALER

### 1. General

- 1.01 DESCRIPTION: Abrasion and chemical-resistant sealer over all interior concrete floors.
- 1.02 RELATED WORK SPECIFIED IN OTHER SECTIONS: Cast-in-place Concrete, Section 03300.
- 1.03 QUALITY ASSURANCE:
- A. Applicator Qualifications: Minimum of two years experience on comparable projects.
  - B. For Applicable Standards: For use on Class 1, 2, 3 and 4 concrete floors as classified in Table 1.1 ACI Standard 302-69 and UL classified, non-slip Type FTM-2.
  - C. Manufacturer's recommended maintenance instructions.
- 1.04 SUBMITTALS:
- A. Furnish certification that materials meet Specifications requirements.
  - B. Furnish five copies of manufacturer's recommended instructions for application of chemical-resistant sealer for interior concrete floors.
- 1.05 PRODUCT DELIVERY, STORAGE AND HANDLING:
- A. Deliver products in manufacturer's original containers with seals and labels intact.
  - B. Store materials in enclosed space protected from weather and out of direct rays of sun.
  - C. Store materials off ground.
  - D. Maintain storage temperature as recommended by manufacturer.
- 1.06 ENVIRONMENTAL REQUIREMENTS: Do not mix or apply materials when temperature is less than that recommended by manufacturer.

### 2. Products

- 2.01 SEALER:
- A. Acceptable Manufacturers: Sonneborn Sonoplex as a standard of quality.
  - B. Comparable Manufacturers:
    - 1. A. C. Horn.
    - 2. Gifford-Hill.
  - C. Composition and Materials: Sealer shall be a two-component catalyzed epoxy resin coating.
  - D. Color shall be gray.
  - E. Coverage: 250 SF per gallon per coat.
  - F. Drying Time: Allow drying time between coats as recommended by the manufacturer.

### 3. Execution

#### 3.01 INSTALLATION:

- A. Sealer shall be mixed in strict accordance with manufacturer's recommendation.
- B. Concrete must be thoroughly cured 30 days prior to sealer application.
- C. Surface Preparation:
  - 1. Holes, crevices, spalled or disintegrated areas shall be properly patched or filled.
  - 2. Surface shall be free of all soil, dust, loose material, oil, grease, paint, parting in curing compounds and other foreign matter.
  - 3. Surface shall be cleaned and allowed to dry thoroughly. Cleanse all dirt or contaminated floors with a hot TSP solution (trisodium phosphate). Rinse thoroughly with clean water.
  - 4. Acid etch the floor with 1:1 solution by volume of 18-20 Baume muriatic acid and water. Apply to floor and allow to stand until all bubbling ceases.
  - 5. Rinse with clean water and squeegee until damp.
  - 6. Repeat rinsing operation again to remove all acid. Allow to dry thoroughly before coating with sealer.
  - 7. Floors shall be absolutely dry per sealer manufacturer's recommendations.
- D. Application: Two coats of sealer shall be applied.
  - 1. Thin first coat as recommended by manufacturer using "Reducer 990."
  - 2. Upon drying, the first coat should have a matte or flat finish to the eye and leave a barely visible film.
  - 3. Allow a minimum of five hours between coats.
  - 4. Apply the-second coat, unthinned, within 24 hours after the first coat.

END OF SECTION

## APPENDIX B

### Special Conditions

1. This initial term of the contract will be in full force and effect through June 30, 2026, with an option to extend by mutual written agreement between the successful bidder and the District for three (3) twelve-month (12-month) increments. In no event will the contract, including extensions, exceed sixty (60) months. Quoted prices must stay in effect for the initial term after award of bid. The District may grant, upon written request, a price adjustment to compensate for inflation; this adjustment must be requested prior to April 30<sup>th</sup> of each year for the upcoming renewal year. The adjustment will be effective upon renewal of the contract and shall not exceed the percentage of change in the Consumer Price Index (CPI) for the Los Angeles-Long Beach-Anaheim areas for the period ending March 31<sup>st</sup> of the given contract renewal.
2. The Contractor will provide bonding for all projects exceeding \$25,000. Bonding will include performance and payment bonds and shall be listed as a line item cost on the proposal, separate from the material price. Bonding cost will not exceed a 3% value of the project being executed. The bond price shall not be added to the unit pricing within the bid.
3. A Notice of Completion will be required on all individual jobs of \$114,500 (2024 bid threshold or as issued yearly by the California Department of Education) or more with a five (5) percent retention hold on those jobs.
4. Payments will be made by the District to Contractor within thirty (30) days of submittal of invoice, providing work has been accepted by District inspectors. Five (5) percent retention will be withheld until the District's Governing Board has accepted the job as satisfactorily completed and thirty-five (35) days after a Notice of Completion has been filed.
5. The contractor shall comply with all applicable codes, ordinances, and safety regulations.
6. The contractor shall notify the Director of Maintenance and Operations or his representative a minimum of two (2) days in advance before starting any phase of this contract. At that time, a starting priority per site will be established.
7. The work consists of, but is not limited to, the installation of new materials and removal of and replacement of existing concrete.
8. The contractor shall provide all labor, equipment, tools, and material necessary to complete this work.
9. The Contractor shall, at all times, keep the premises free from accumulation of waste material or rubbish, maintain area in a neat, orderly manner, and leave premises in a broom clean condition at the completion of each day's work. All debris shall be disposed of off premises by Contractor.
10. The contractor shall exercise extreme caution in demolition and compaction where underground utilities are indicated and pavement repairs indicate underground utilities.

11. The raising and lowering of utility boxes to finish grade shall be part of the contract.
12. Any damage to buildings, grounds, pavement, etc., resulting from the construction operation shall be repaired by the contractor in an approved manner at no cost to the District.
13. The contractor shall exercise all reasonable and necessary means to abate undue dust and noise at all times.
14. The contractor shall notify the District's Maintenance Office one (1) day in advance before either subgrade, base, or concrete work is started at any site.
15. Parking or road areas shall receive 1/2" type III C-3 asphalt concrete and conform to Caltrans specifications.
16. The District reserves the right to use other concrete contractors outside this contract.

## APPENDIX C

### Drawings



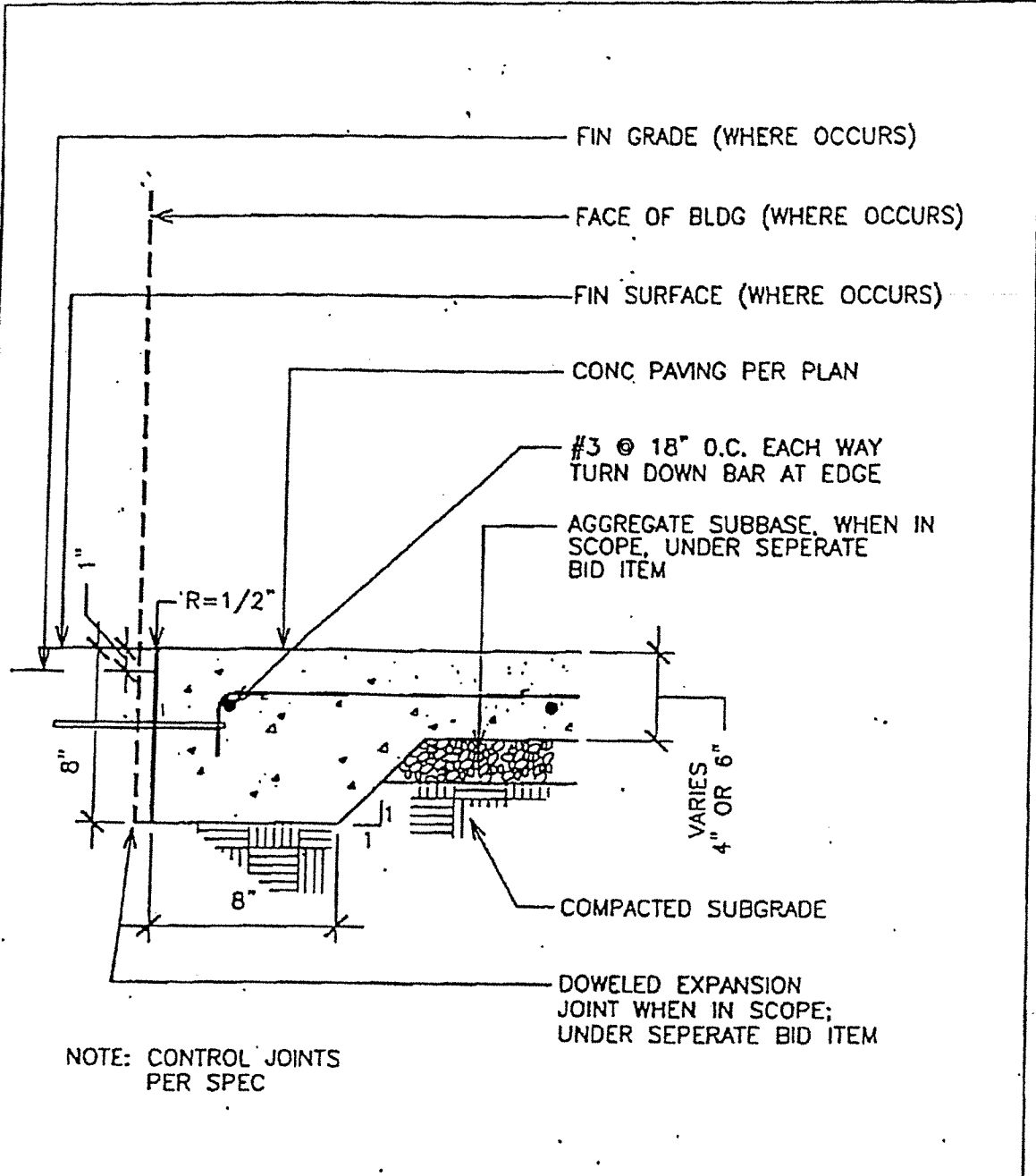

# CONCRETE EDGE - TYPICAL

SCALE
1 1/2" = 1'-0"

Sheet

#301

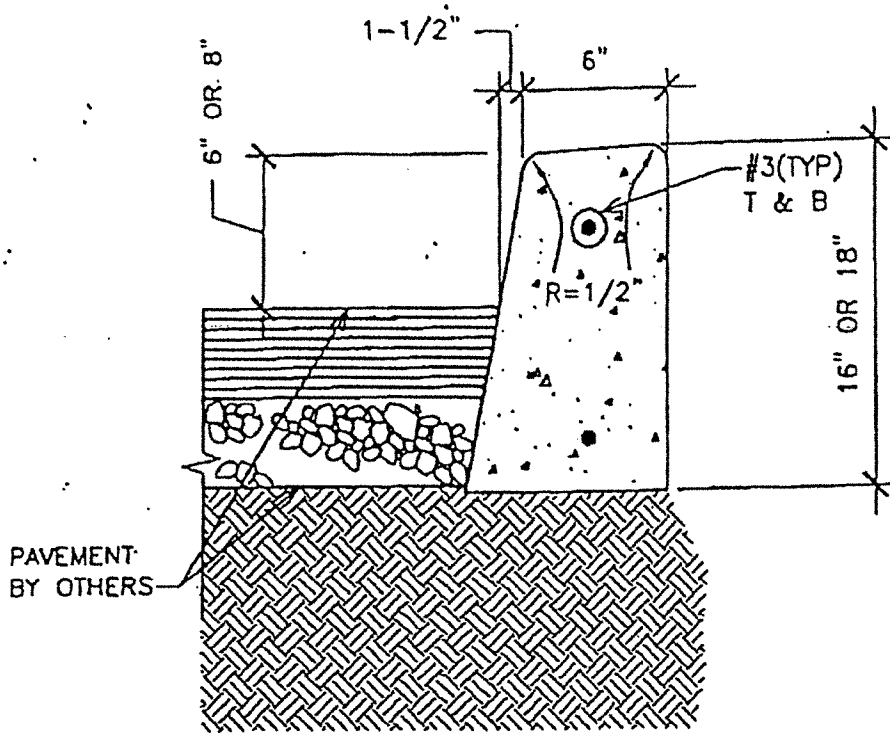

NOTE: PLACE JOINTS PER SPEC

CURB

SCALE
N.T.S.

Sheet

#302

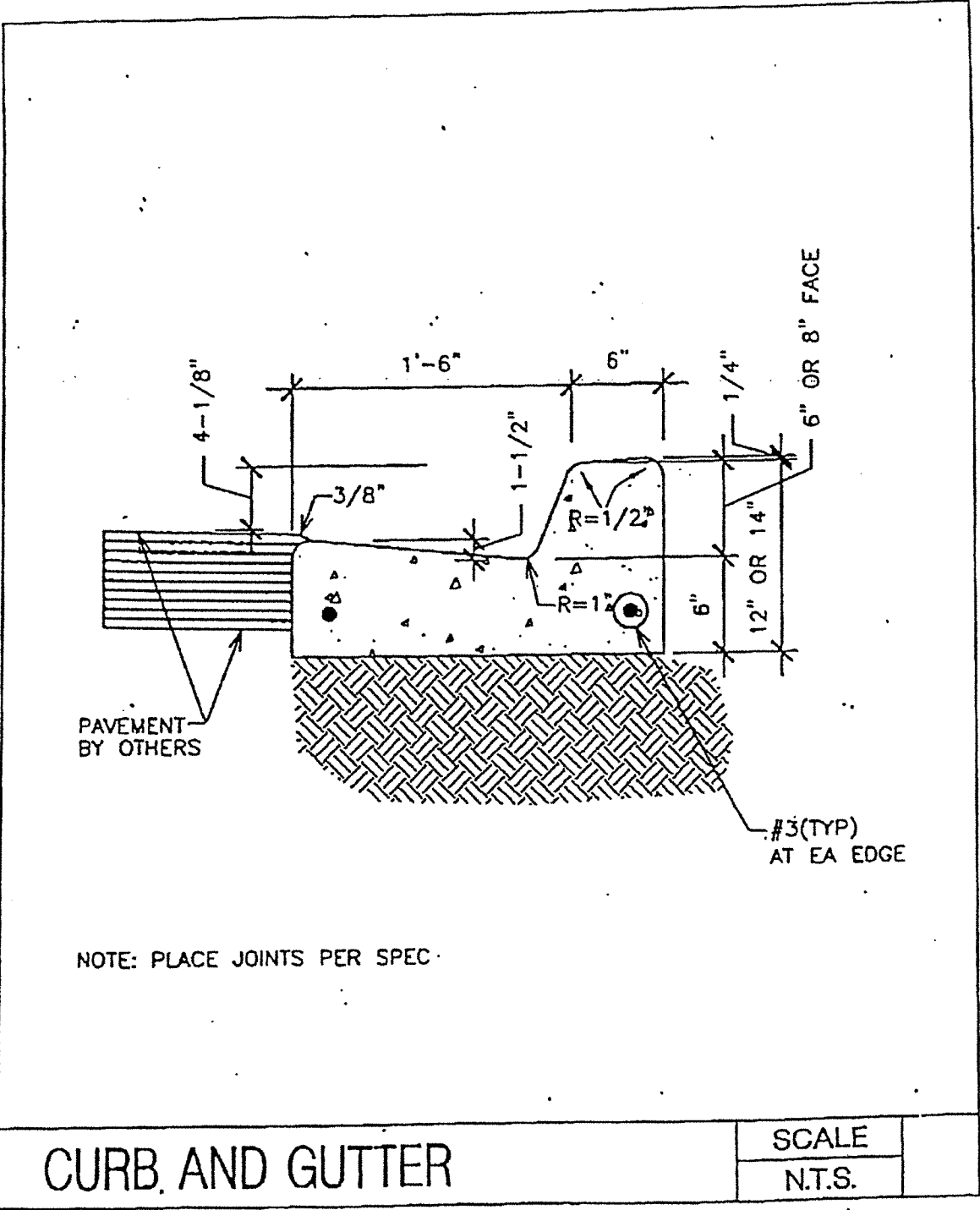

Sheet

#303

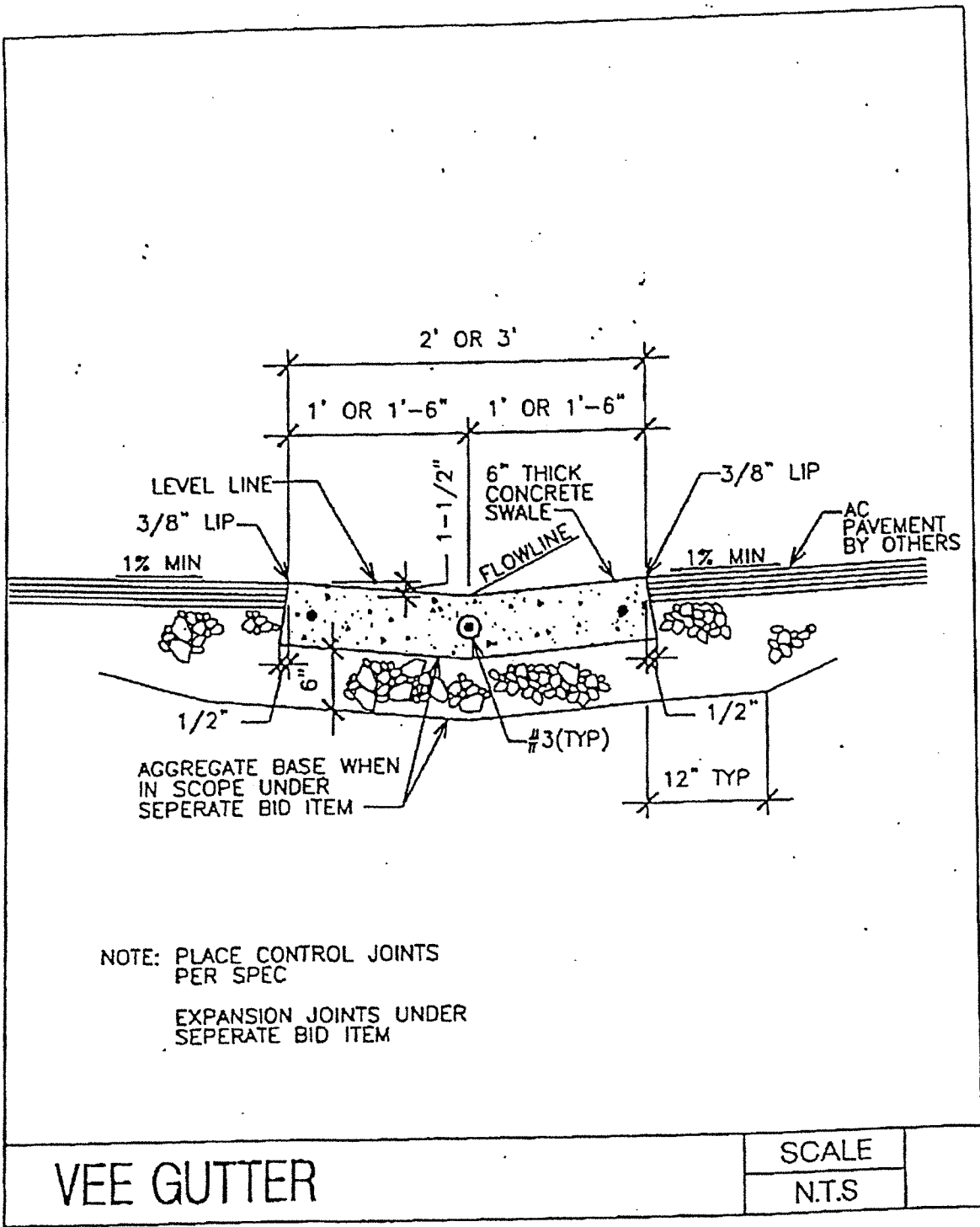

Sheet

#304

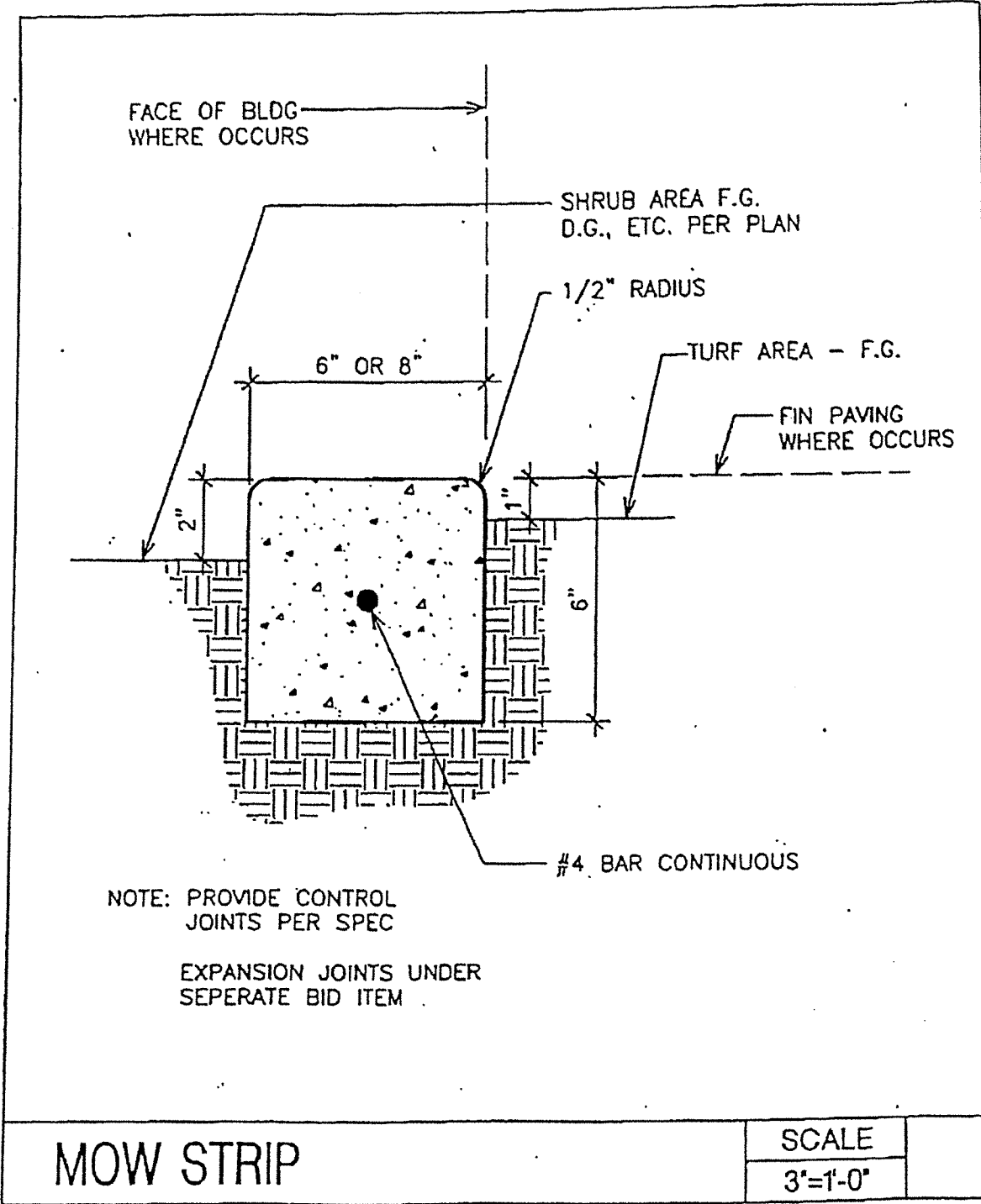

Sheet

#305

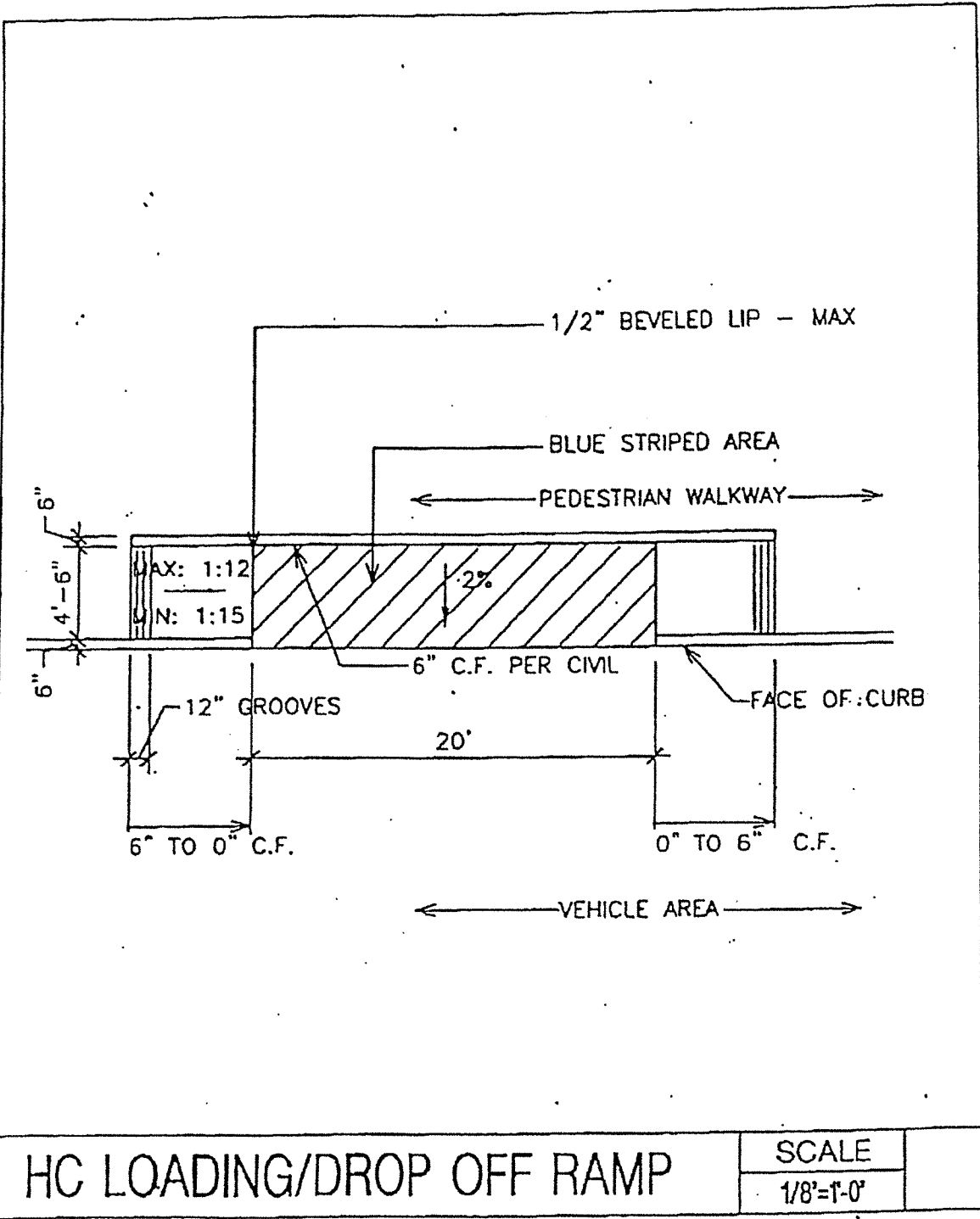

Sheet

#310

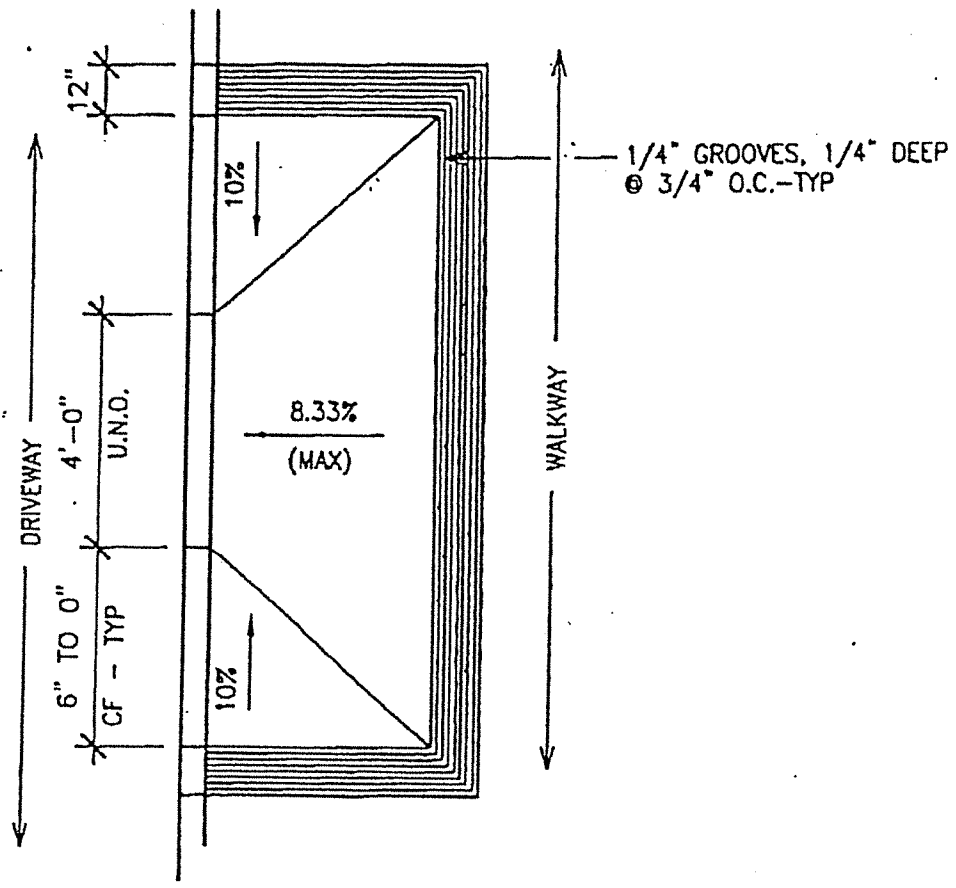

NOTE:  
 RAMP SHALL BE 4" CONC W/#3 @ 12" O.C. @ MIDPOINT

<h1>HC INLET CURB RAMP</h1>	SCALE	
	1/4" = 1'-0"	

Sheet

#311

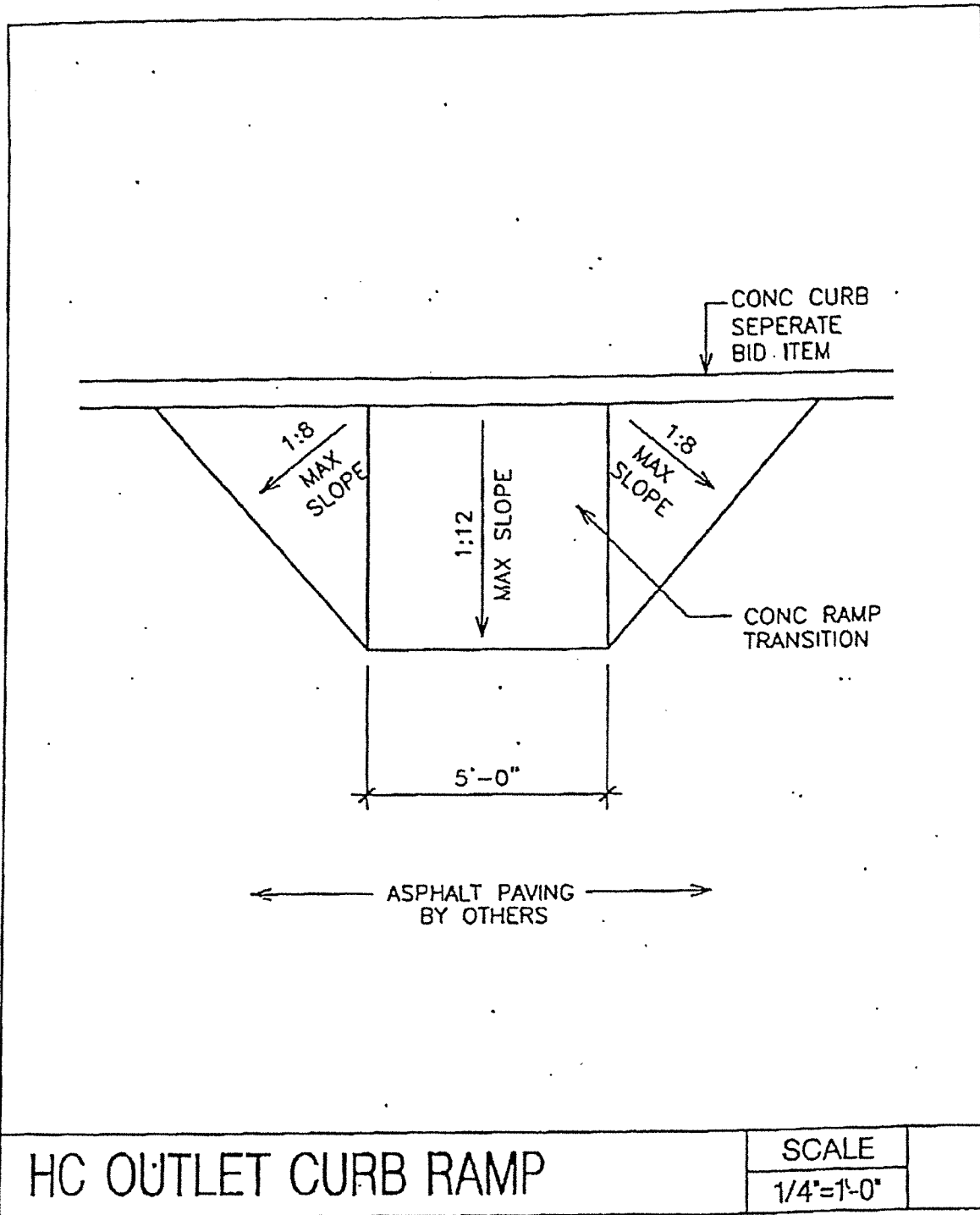

Sheet

#312



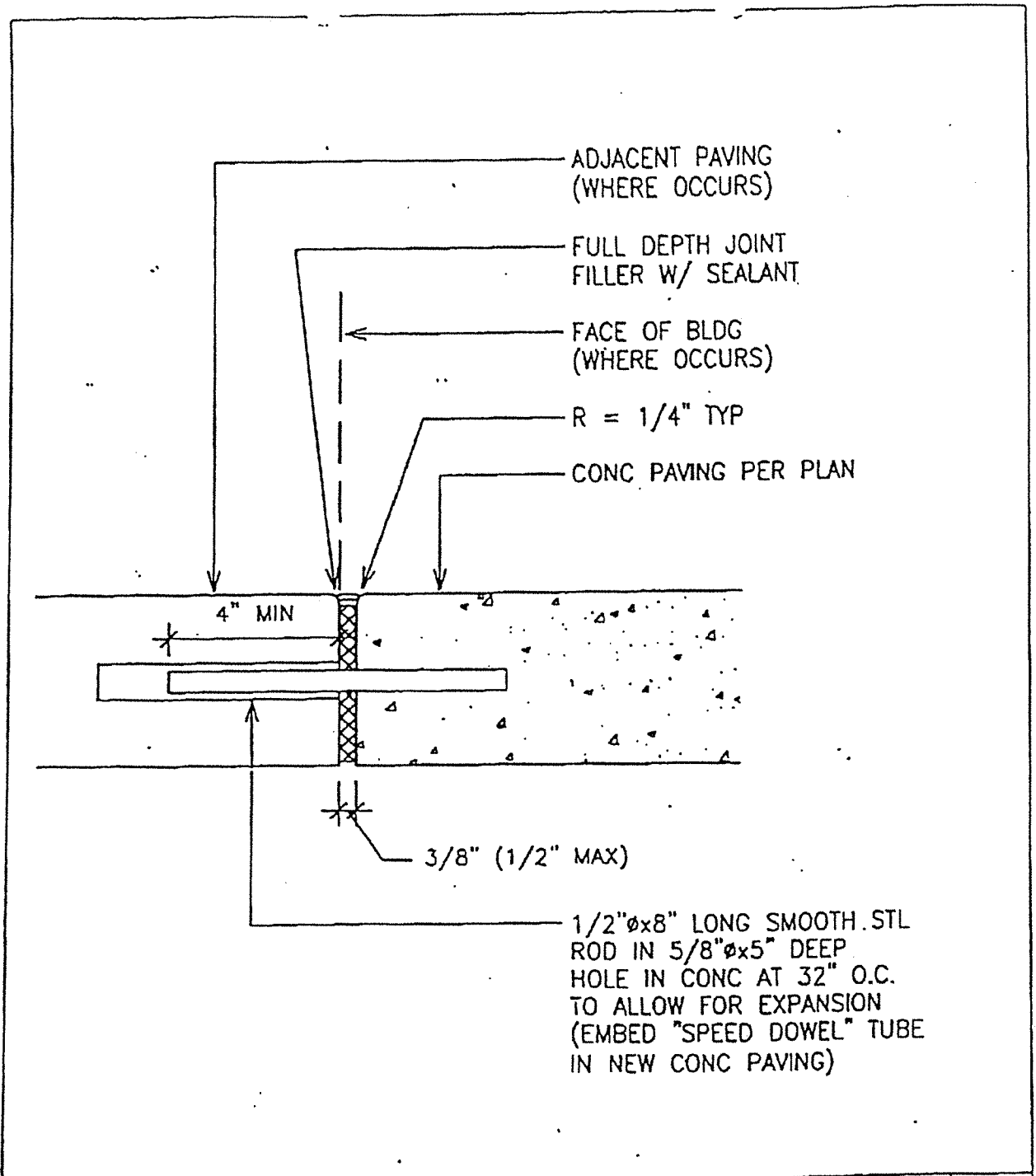

EXPANSION JOINT	SCALE	
	3"=1'-0"	

Sheet

#313

NOT FOR DSA APPROVAL PER SECTION 4-314  
CALIFORNIA BUILDING STANDARDS ADMINISTRATION CODE

PLH & ASSOCIATES INC. SHALL NOT BE HELD RESPONSIBLE FOR STRUCTURAL INTEGRITY OF POLE BASE DETAIL WITHOUT SIGNED APPROVAL FROM LICENSED STRUCTURAL ENGINEER.

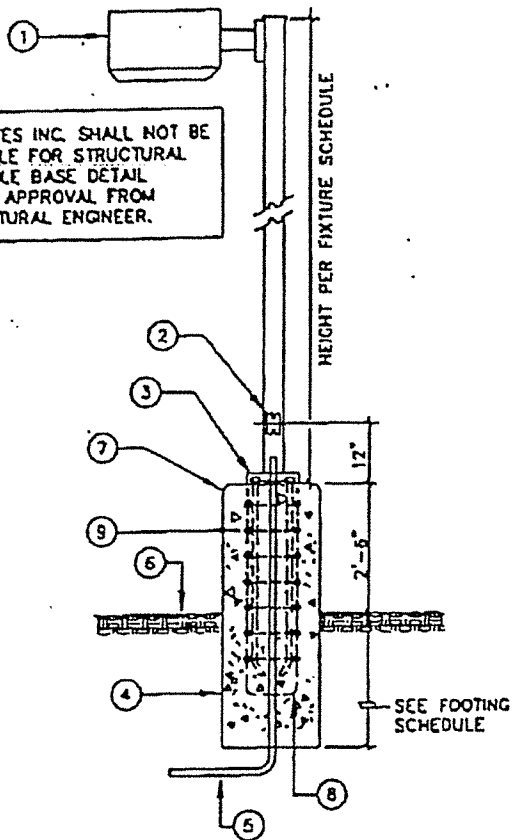

POLE BASE DETAIL  
N.T.S.

### FOOTING SCHEDULE

POLE LENGTH	FOOTING LENGTH BELOW GRADE	FOOTING DIAMETER
0' — 15'-0"	3'-0"	1'-6"
15'-1" — 20'-0"	4'-0"	2'-6"
20'-1" — 25'-0"	5'-0"	2'-6"
25'-1" — 30'-0"	6'-0"	2'-6"

- THE LIGHTING STANDARD SHALL BE PLACED SO THAT THE FOOTING AND THE STANDARD LINE UP WITH THE CLOSEST PARKING DIVIDING STRIP.
- FINAL FOOTING STRUCTURAL REQUIREMENTS SHALL BE AS DIRECTED BY THE ARCHITECT.

### POLETOP FOOTING NOTES

- ① DENOTES POLETOP FIXTURE (POLE DIAMETER SHALL BE THE SAME FOR SINGLE, DOUBLE OR QUAD TYPE FIXTURE)
- ② DENOTES GROUND STUD AND HAND HOLE.
- ③ DENOTES BASEPLATE AND ANCHOR BOLTS COMPLETE WITH BASE COVER PLATE PER POLE MANUFACTURER'S REQUIREMENTS.
- ④ DENOTES ROUND CONCRETE FOOTING. REFER TO 'FOOTING SCHEDULE' ABOVE FOR SIZE.
- ⑤ DENOTES ELECTRICAL CONDUIT ROUTED 2'-0" MINIMUM BELOW GRADE.
- ⑥ DENOTES FINISHED GRADE.
- ⑦ DENOTES 4" PCC CAP WITH ROUND EDGES.
- ⑧ DENOTES 6 INCH X 6 INCH X 10 X 10 WIRE MESH AROUND REBAR.
- ⑨ DENOTES (4) #4 REBAR.

Sheet

#314

TO DISCOURAGE SKATEBOARD  
USE SAWCUT 1" WIDE REVEAL  
AT 1'-6" O.C.

3/4" CHAMFER TYP

DAMP PROOFING

PLANTER

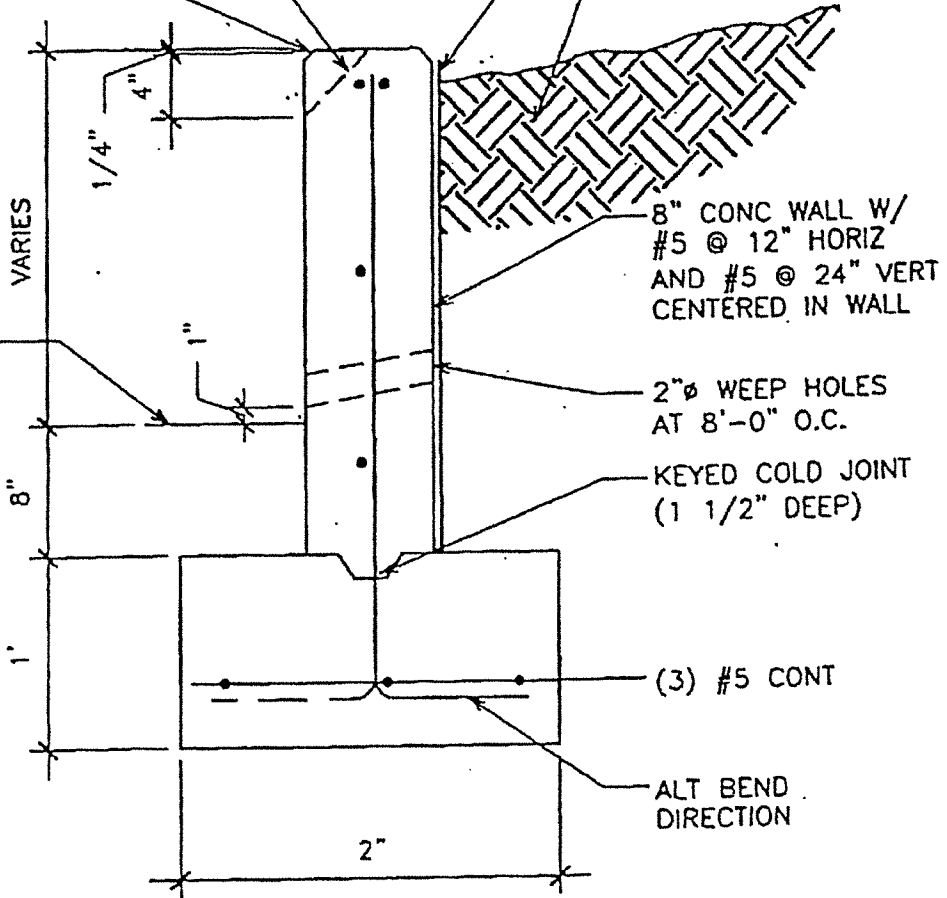

FINISHED SURFACE  
PER ARCH'L

8" CONC WALL W/  
#5 @ 12" HORIZ  
AND #5 @ 24" VERT  
CENTERED IN WALL

2"Ø WEEP HOLES  
AT 8'-0" O.C.

KEYED COLD JOINT  
(1 1/2" DEEP)

(3) #5 CONT

ALT BEND  
DIRECTION

NOTE: INSTALL CONTROL  
JOINTS AT 15' O.C.

# TYPICAL PLANTER WALL

SCALE	
N.T.S	

Sheet

#315

4"Ø X12" DEEP FENCE  
POST SLEEVES AT 10'-0" O.C.

3/4" CHAMFER TYP

DAMP PROOFING

PLANTER

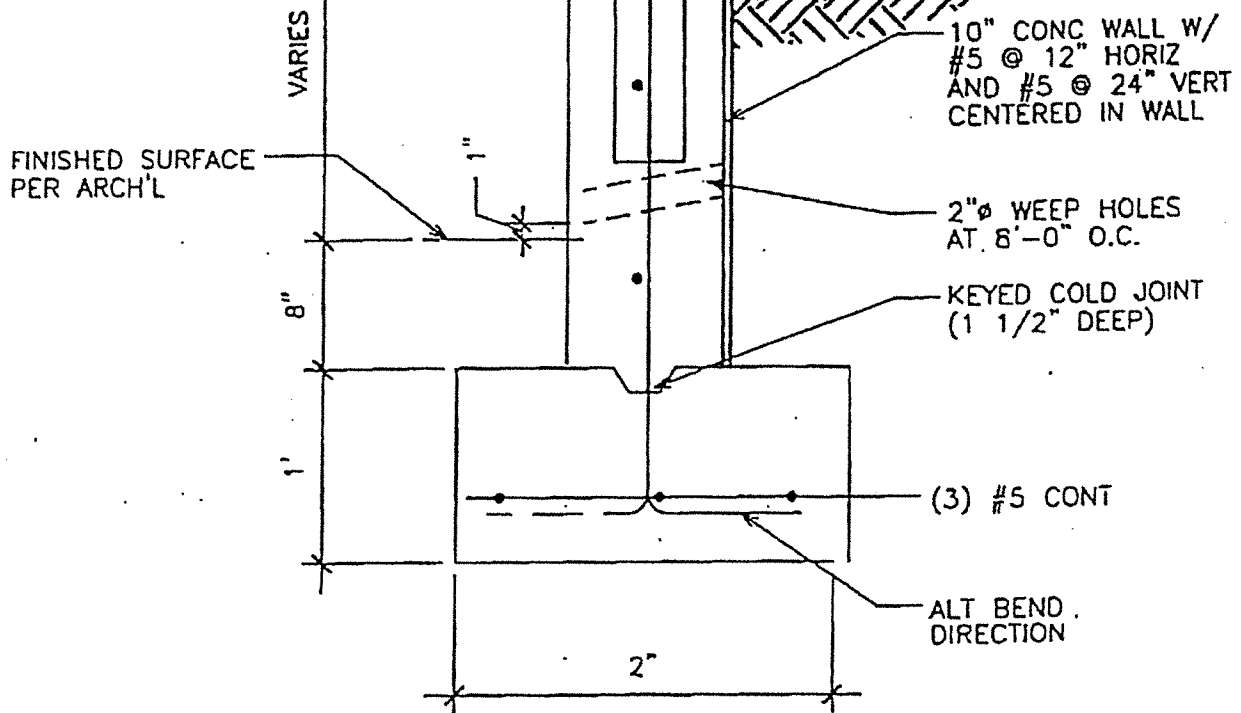

NOTE: INSTALL CONTROL JOINTS  
AT EACH FENCE SLEEVE

# PLANTER WALL W/SLEEVES

SCALE

N.T.S

Sheet

#316

## APPENDIX D

### General Conditions

**TABLE OF CONTENTS TO THE GENERAL CONDITIONS**

<u>ARTICLE</u>	<u>PAGE</u>
1. DEFINITIONS.....	3
2. STATUS OF CONTRACTOR.....	4
3. CHANGE IN NAME AND NATURE OF CONTRACTOR'S LEGAL ENTITY .....	4
4. CONTRACTOR'S SUPERVISION, PROSECUTION AND PROGRESS .....	5
5. SUBCONTRACTORS .....	6
6. PROHIBITED INTERESTS.....	7
7. DISTRICT'S INSPECTOR.....	7
8. ARCHITECT'S STATUS.....	8
9. NOTICE OF TAXABLE POSSESSORY INTEREST .....	8
10. ASSIGNMENT OF ANTITRUST ACTIONS .....	8
11. OTHER CONTRACTS .....	9
12. OCCUPANCY.....	10
13. DISTRICT'S RIGHT TO TERMINATE AGREEMENT .....	10
14. BONDS.....	12
15. SUBSTITUTION OF SECURITIES .....	12
16. FIRE INSURANCE.....	13
17. PUBLIC LIABILITY AND PROPERTY DAMAGE INSURANCE .....	13
18. WORKERS' COMPENSATION INSURANCE .....	14
19. PROOF OF CARRIAGE OF INSURANCE .....	14
20. DRAWINGS AND SPECIFICATIONS.....	15
21. OWNERSHIP OF DRAWINGS.....	17
22. DETAIL DRAWINGS AND INSTRUCTIONS .....	17
23. SHOP DRAWINGS.....	18
24. LAYOUT AND FIELD ENGINEERING .....	20
25. SOILS INVESTIGATION REPORT .....	20
26. TESTS AND INSPECTIONS.....	21
27. TRENCHES.....	22
28. DOCUMENTS ON WORK.....	23
29. STATE AUDIT.....	23
30. SUBSTITUTIONS.....	23
31. SAMPLES.....	25
32. PROGRESS SCHEDULE .....	26
33. MATERIALS AND WORK.....	27
34. INTEGRATION OF WORK .....	28
35. OBTAINING OF PERMITS, LICENSES AND EASEMENTS .....	29
36. SURVEYS .....	29
37. EXISTING UTILITY LINES; REMOVAL, RESTORATION.....	29

38.	WORK TO COMPLY WITH APPLICABLE LAWS AND REGULATIONS.....	30
39.	ACCESS TO WORK.....	30
40.	PAYMENTS BY CONTRACTOR .....	30
41.	INSPECTOR'S FIELD OFFICE.....	31
42.	UTILITIES.....	31
43.	SANITARY FACILITIES.....	31
44.	CLEANING UP .....	32
45.	PATENTS, ROYALTIES, AND INDEMNITIES .....	32
46.	GUARANTEE .....	32
47.	DUTY TO PROVIDE FIT WORKERS .....	34
48.	WAGE RATES, TRAVEL AND SUBSISTENCE.....	34
49.	HOURS OF WORK.....	35
50.	PAYROLL RECORDS.....	36
51.	APPRENTICES .....	37
52.	LABOR - FIRST AID.....	39
53.	PROTECTION OF PERSONS AND PROPERTY .....	39
54.	NON-DISCRIMINATION .....	40
55.	SCHEDULE OF VALUES AND PERIODICAL ESTIMATES .....	40
56.	CONTRACTOR CLAIMS .....	41
57.	DISPUTES - ARCHITECT'S DECISIONS .....	41
58.	PAYMENTS.....	42
59.	CHANGES AND EXTRA WORK .....	43
60.	COMPLETION.....	49
61.	ADJUSTMENTS TO CONTRACT PRICE.....	49
62.	CORRECTION OF WORK.....	49
63.	EXTENSION OF TIME - LIQUIDATED DAMAGES.....	50
64.	PAYMENTS WITHHELD.....	50
65.	TAXES .....	52
66.	NO ASSIGNMENT .....	52
67.	NOTICE.....	52
68.	NO WAIVER.....	53
69.	NON-UTILIZATION OF ASBESTOS MATERIAL .....	53
70.	LEAD .....	54
71.	CRIMINAL RECORDS CHECK.....	54
72.	DISABLED VETERAN BUSINESS ENTERPRISES .....	55
73.	TOBACCO FREE POLICY .....	55
74.	GOVERNING LAW .....	55

## GENERAL CONDITIONS

### ARTICLE 1. DEFINITIONS

- (a) Action of the Governing Board is a vote of a majority of the members in a lawful meeting.
- (b) Addenda are the changes in plans, specifications, drawings, and/or Project Documents which have been authorized in writing by the DISTRICT or ARCHITECT, and which alter, explain, or clarify the Project Documents prior to the bid deadline.
- (c) Approval means written authorization by ARCHITECT or DISTRICT.
- (d) Agreement includes collectively all Project Documents.
- (e) Project Documents includes collectively, to wit: Notice Calling for Bids, Information for Bidders, Bid Form, Bid Security, Designation of Subcontractor form, Information Required of Bidder, all prequalification forms submitted pursuant to Public Contract Code Section 20111.5, if any, Noncollusion Affidavit, Workers' Compensation Certificate, Faithful Performance Bond, Payment Bond, Agreement, Escrow Agreement, Drug-Free Workplace Certification, Criminal Records Check Certification, Change Order forms, Shop Drawing Transmittals form, Insurance Certificates and Endorsements, Guarantee form, Contractor's Certificate Regarding Non-Asbestos Containing Materials, Disabled Veteran Business Enterprises Certification, if applicable, General Conditions, Supplemental Conditions, if any, Special Conditions, if any, Drawings, Specifications, and all modifications, addenda and amendments thereto. The Project Documents are complementary, and what is called for by any one shall be as binding as if called for by all.
- (f) CONTRACTOR or DISTRICT are those mentioned as such in the Agreement. They are treated throughout the Project Documents as if they are of singular number and neuter gender.
- (g) DISTRICT is the Governing Board or its duly authorized representative.
- (h) Locality in which the work is performed means the county and city in which the work is done.
- (i) Project is the planned undertaking as provided for in the Project Documents by DISTRICT and CONTRACTOR.
- (j) Provide shall include "provide complete in place," that is, "furnish and install."
- (k) Safety Orders are those issued by the Division of Industrial Safety and OSHA safety and health standards for construction.



(l) Standards, Rules, and Regulations referred to are recognized printed standards and shall be considered as one and a part of these specifications within limits specified.

(m) Subcontractor, as used herein, includes those having a direct contractual relationship with CONTRACTOR and one who furnishes material worked to a special design according to plans, drawings, and specifications, but does not include one who merely furnishes material not so worked.

(n) Surety is the person, firm, or corporation that executes as a California admitted surety insurer, the CONTRACTOR's Bid Security, faithful performance bond and payment bond.

(o) Work of the CONTRACTOR or subcontractor includes labor or materials (including, without limitation, equipment and appliances) or both, incorporated in, or to be incorporated in the Project.

(p) Workers includes laborer, worker, or mechanic.

## ARTICLE 2. STATUS OF CONTRACTOR

(a) CONTRACTOR is and shall at all times be deemed to be an independent contractor and shall be wholly responsible for the manner in which it performs the services required of it by the terms of the Project Documents. Nothing herein contained shall be construed as creating the relationship of employer and employee, or principal and agent, between the DISTRICT and CONTRACTOR or any of CONTRACTOR's agents or employees. CONTRACTOR assumes exclusively the responsibility for the acts of its employees as they relate to the services to be provided during the course and scope of their employment. CONTRACTOR, its agents and employees shall not be entitled to any rights or privileges of DISTRICT employees and shall not be considered in any manner to be DISTRICT employees. DISTRICT shall be permitted to monitor the activities of the CONTRACTOR to determine compliance with the terms of the Project Documents.

(b) Contractors are required by law to be licensed and regulated by the Contractors' State License Board. Any CONTRACTOR not so licensed is subject to penalties under the law, and the contract will be considered void pursuant to Section 7028.7 of the Business and Professions Code. Any questions concerning a contractor may be referred to the Registrar, Contractors' State License Board, 9821 Business Park Drive, P. O. Box 26000, Sacramento, CA 95826.

## ARTICLE 3. CHANGE IN NAME AND NATURE OF CONTRACTOR'S LEGAL ENTITY

Before CONTRACTOR makes any change in the name or legal nature of the CONTRACTOR's entity, CONTRACTOR shall first notify the DISTRICT in writing and cooperate with DISTRICT in making such changes as the DISTRICT may request in the Project Documents.

#### ARTICLE 4. CONTRACTOR'S SUPERVISION, PROSECUTION AND PROGRESS

(a) During progress of the work, CONTRACTOR shall keep on the work site a competent superintendent satisfactory to DISTRICT. Before commencing the work herein, CONTRACTOR shall give written notice to DISTRICT and ARCHITECT of the name, qualifications and experience of such superintendent. If Superintendent is found unsatisfactory by DISTRICT, CONTRACTOR shall replace the Superintendent with one acceptable to the DISTRICT. Superintendent shall not be changed except with written consent of DISTRICT, unless a superintendent proves to be unsatisfactory to CONTRACTOR and ceases to be in its employ, in which case, CONTRACTOR shall notify DISTRICT and ARCHITECT in writing and replace said Superintendent with one acceptable to the DISTRICT. Superintendent shall represent CONTRACTOR and all directions given to Superintendent shall be as binding as if given to CONTRACTOR.

(b) CONTRACTOR shall supervise and direct the work competently and efficiently, devoting such attention thereto and applying such skills as may be necessary to perform the work in accordance with the Project Documents. CONTRACTOR shall carefully study and compare all plans, drawings, specifications, and other instructions and shall at once report to ARCHITECT any error, inconsistency or omission which CONTRACTOR or its employees may discover. The CONTRACTOR represents itself to DISTRICT as a skilled, knowledgeable, and experienced CONTRACTOR. The CONTRACTOR shall carefully study and compare the Project Documents with each other, and shall at once report to the ARCHITECT any errors, inconsistencies, or omissions discovered. The CONTRACTOR shall be liable to the DISTRICT for damage resulting from errors, inconsistencies, or omissions in the Project Documents that the CONTRACTOR recognized and which CONTRACTOR knowingly failed to report and which a similarly skilled, knowledgeable, and experienced contractor would have discovered.

(c) The CONTRACTOR shall verify all indicated dimensions before ordering materials or equipment, or before performing work. The CONTRACTOR shall take field measurements, verify field conditions, and shall carefully compare such field measurements and conditions and other information known to the CONTRACTOR with the Project Documents before commencing work. Errors, inconsistencies or omissions discovered shall be reported to the DISTRICT at once. Upon commencement of any item of work, the CONTRACTOR shall be responsible for dimensions related to such item of work and shall make any corrections necessary to make work properly fit at no additional cost to DISTRICT. This responsibility for verification of dimensions is a non-delegable duty and may not be delegated to subcontractors or agents.

(d) Omissions from the plans, drawings or specifications, or the misdescription of details of work which are manifestly necessary to carry out the intent of the plans, drawings and specifications, or which are customarily performed, shall not relieve the CONTRACTOR from performing such omitted or misdescribed work, but they shall be performed as if fully and correctly set forth and described in the plans, drawings and specifications.

(e) The CONTRACTOR shall be solely responsible for the means, methods, techniques, sequences, and procedures of construction. The CONTRACTOR shall be responsible to see that the finished work complies accurately with the Project Documents.

#### ARTICLE 5. SUBCONTRACTORS

(a) CONTRACTOR agrees to bind every subcontractor by terms of the Project Documents as far as such terms are applicable to subcontractor's work. If CONTRACTOR shall subcontract any part of the work, CONTRACTOR shall be as fully responsible to DISTRICT for acts and omissions of any subcontractor and of persons either directly or indirectly employed by any subcontractor, as it is for acts and omissions of persons directly employed by CONTRACTOR. Nothing contained in Project Documents shall create any contractual relation between any subcontractor and DISTRICT, nor shall the contract documents be construed to be for the benefit of any subcontractor.

(b) DISTRICT's consent to any subcontractor shall not in any way relieve CONTRACTOR of any obligations under the Project Documents and no such consent shall be deemed to waive any provision of any Project Document.

(c) CONTRACTOR must submit with its bid, a Designation of Subcontractors pursuant to the Subletting and Subcontracting Fair Practices Act. If CONTRACTOR specifies more than one subcontractor for the same portion of work or fails to specify a subcontractor, and such portion of the work exceeds one-half of one percent of the total bid, CONTRACTOR agrees that it is fully qualified to perform and shall perform such work itself, unless CONTRACTOR provides for substitution or addition of subcontractors. Substitution or addition of subcontractors shall be permitted only as authorized under the Subletting and Subcontracting Fair Practices Act, Public Contract Code Section 4100, et. seq.

(d) In accordance with Business and Professions Code Section 7059, if CONTRACTOR is designated as a "specialty contractor" (as defined in Section 7058 of the Public Contract Code), all of the work to be performed outside of the CONTRACTOR's license specialty shall be performed by a licensed subcontractor in compliance with the Subletting and Subcontracting Fair Practices Act, Public Contract Code Section 4100, et seq.

(e) A copy of each subcontract, if in writing, or, if not in writing, then a written statement signed by the CONTRACTOR giving the name of the subcontractor and the terms and conditions of such subcontract, shall be filed with the DISTRICT before the subcontractor begins work. Each subcontract shall contain a reference to the Agreement between the DISTRICT and the CONTRACTOR and the terms of that Agreement and all parts of the Project Documents shall be made a part of such subcontract insofar as applicable to the work covered thereby. Each subcontract will provide for termination in accordance with Article 13 of these General Conditions. Each subcontract shall provide for its annulment by the CONTRACTOR at the order of the ARCHITECT if in the ARCHITECT'S opinion the subcontractor fails to comply with the requirements of the

Project Documents insofar as the same may be applicable to this work. Nothing herein contained shall relieve the CONTRACTOR of any liability or obligation hereunder.

#### ARTICLE 6. PROHIBITED INTERESTS

No official of DISTRICT who is authorized in such capacity and on behalf of DISTRICT to negotiate, make, accept, or approve, or to take part in negotiating, making, accepting or approving any architectural, engineering, inspection, construction or material supply contract or any subcontract in connection with construction of the Project, shall become directly or indirectly interested financially in this Project or in any part thereof. No officer, employee, architect, attorney, engineer or inspector of or for DISTRICT who is authorized in such capacity and on behalf of DISTRICT to exercise any executive, supervisory or other similar functions in connection with construction of Project shall become directly or indirectly interested financially in this Project or in any part thereof. CONTRACTOR shall receive no compensation and shall repay DISTRICT for any compensation received by CONTRACTOR hereunder, should CONTRACTOR aid, abet or knowingly participate in violation of this Article 6.

#### ARTICLE 7. DISTRICT'S INSPECTOR

- (a) One or more Inspector(s), including special inspectors, as required, will be employed by DISTRICT and will be assigned to the Project.
- (b) No work shall be performed by the CONTRACTOR solely upon the instructions or comments by the Inspector. The Inspector has no authority to interpret the Project Documents or order extra work and any extra work performed without the written instruction of the DISTRICT shall be at CONTRACTOR's sole cost and expense and there will be no delay damages incurred by DISTRICT for such work.
- (c) No work shall be carried on except with the knowledge and under the inspection of said Inspector(s). He/she shall have free access to any or all parts of work at any time. CONTRACTOR shall furnish Inspector reasonable opportunities for obtaining such information as may be necessary to keep Inspector fully informed respecting progress and manner of work and character of materials. Inspection of work shall not relieve CONTRACTOR from any obligation to fulfill the Project Documents. Inspector or ARCHITECT shall have authority to stop work whenever provisions of Project Documents are not being complied with and such noncompliance is discovered. CONTRACTOR shall instruct its employees accordingly.
- (d) CONTRACTOR understands and agrees that the Inspector for the Project may also serve concurrently as inspector for other DISTRICT projects and may not therefore be available on site during the entire work day. It shall be the responsibility of CONTRACTOR to notify the Inspector not less than twenty-four (24) hours in advance of materials and equipment deliveries and required inspections.

## ARTICLE 8. ARCHITECT'S STATUS

- (a) The ARCHITECT shall be the DISTRICT's representative during construction and shall observe the progress and quality of the work on behalf of the DISTRICT. ARCHITECT shall have the authority to act on behalf of DISTRICT only to the extent expressly provided in the Project Documents. ARCHITECT shall have authority to stop work whenever such stoppage may be necessary in ARCHITECT'S reasonable opinion to ensure the proper execution of the Project Documents.
- (b) The ARCHITECT shall be, in the first instance, the judge of the performance of the work. ARCHITECT shall exercise authority under the Project Documents to enforce CONTRACTOR's faithful performance.
- (c) The ARCHITECT shall have all authority and responsibility established by law. The ARCHITECT has the authority to enforce compliance with the Project Documents and the CONTRACTOR shall promptly comply with instructions from the ARCHITECT or an authorized representative of the ARCHITECT.
- (d) On all questions related to the quantities, the acceptability of material, equipment or workmanship, the execution, progress or sequence of work, the interpretation of plans, specifications or drawings, and the acceptable performance of the CONTRACTOR pursuant to the decision of the ARCHITECT shall govern and shall be precedent to any payment unless otherwise ordered by the Governing Board. The progress and completion of the work shall not be impaired or delayed by virtue of any question or dispute arising out of or related to the foregoing matters and the instructions of the ARCHITECT relating thereto.
- (e) General supervision and direction of the work by the ARCHITECT shall in no way imply that the ARCHITECT or his or her representatives are in any way responsible for the safety of the CONTRACTOR or its employees or that the ARCHITECT or his or her representatives will maintain supervision over the CONTRACTOR's construction methods or personnel other than to ensure that the quality of the finished work is in accordance with the Project Documents.

## ARTICLE 9. NOTICE OF TAXABLE POSSESSORY INTEREST

The terms of the Agreement may result in the creation of a possessory interest. If such a possessory interest is vested in a private party to the Agreement, the private party may be subjected to the payment of property taxes levied on such interest.

## ARTICLE 10. ASSIGNMENT OF ANTITRUST ACTIONS

Public Contract Code Section 7103.5 provides:

In entering into a public works contract or a subcontract to supply goods, services, or materials pursuant to a public works contract, the

contractor or subcontractor offers and agrees to assign to the awarding body (DISTRICT) all rights, title, and interest in and to all causes of action it may have under Section 4 of the Clayton Act (15 U.S.C. Section 15) or under the Cartwright Act (Chapter 2 (commencing with Section 16700) of Part 2 of Division 7 of the Business and Professions Code), arising from purchases of goods, services, or materials pursuant to the public works contract or the subcontract. This assignment shall be made and become effective at the time the awarding body tenders final payment to the contractor, without further acknowledgment by the parties.

CONTRACTOR, for itself and all subcontractors, agrees to assign to DISTRICT all rights, title, and interest in and to all such causes of action CONTRACTOR and all subcontractors may have under the Agreement. This assignment shall become effective at the time DISTRICT tenders final payment to the CONTRACTOR, and CONTRACTOR shall require assignments from all subcontractors to comply herewith.

#### ARTICLE 11. OTHER CONTRACTS

(a) DISTRICT reserves the right to let other contracts in connection with this work. CONTRACTOR shall afford other contractors reasonable opportunity for introduction and storage of their materials and execution of their work and shall properly connect and coordinate its work with such other contractors.

(b) If any part of CONTRACTOR's work depends for proper execution or results upon work of any other contractor, the CONTRACTOR shall inspect and promptly report to ARCHITECT in writing any defects in such work that render it unsuitable for such proper execution and results. CONTRACTOR will be held accountable for damages to DISTRICT for that work which it failed to inspect or should have inspected. CONTRACTOR's failure to inspect and report shall constitute its acceptance of other contractor's work as fit and proper for reception of its work, except as to defects which may develop in other contractors' work after execution of CONTRACTOR's work.

(c) To ensure proper execution of its subsequent work, CONTRACTOR shall measure and inspect work already in place and shall at once report to the ARCHITECT in writing any discrepancy between executed work and Project Documents.

(d) CONTRACTOR shall ascertain to its own satisfaction the scope of the Project and nature of any other contracts that have been or may be awarded by DISTRICT in prosecution of the Project to the end that CONTRACTOR may perform this Agreement in the light of such other contracts, if any.

(e) Nothing herein contained shall be interpreted as granting to CONTRACTOR exclusive occupancy at site of Project. CONTRACTOR shall not cause any unnecessary hindrance or delay to any other contractor working on Project. If simultaneous execution of any contract for Project is likely to cause interference with performance of some other

contract or contracts, DISTRICT shall decide which contractor shall cease work temporarily and which contractor shall continue or whether work can be coordinated so that contractors may proceed simultaneously.

(f) DISTRICT shall not be responsible for any damages suffered or extra costs incurred by CONTRACTOR resulting directly or indirectly from award or performance or attempted performance of any other contract or contracts on Project, or caused by any decision or omission of DISTRICT respecting the order of precedence in performance of contracts.

## ARTICLE 12. OCCUPANCY

DISTRICT reserves the right to occupy buildings and/or portions of the site at any time before completion, and such occupancy shall not constitute final acceptance of any part of work covered by this Agreement, nor shall such occupancy extend the date specified for completion of the work. Beneficial occupancy of building(s) does not commence any warranty period nor shall it entitle CONTRACTOR to any additional compensation due to such occupancy.

## ARTICLE 13. DISTRICT'S RIGHT TO TERMINATE AGREEMENT

(a) Termination for Cause. If the CONTRACTOR refuses or fails to complete the work or any separable part thereof with such diligence as will insure its completion within the time specified or any extension thereof, or fails to complete said work within such time, or if the CONTRACTOR should file a petition for relief as a debtor, or should relief be ordered against CONTRACTOR as a debtor under Title 11 of the United States Code, or if CONTRACTOR should make a general assignment for the benefit of its creditors, or if a receiver should be appointed on account of its insolvency, or if it should refuse or should fail to supply enough properly skilled workers or proper equipment, tools, and materials in the necessary quantity and quality to complete the work in the time specified, or if CONTRACTOR should fail to make prompt payment to subcontractors for materials or labor, or disregard laws or ordinances or instructions of DISTRICT, or if CONTRACTOR or its subcontractors should otherwise be guilty of a violation of any provision of this Agreement, then CONTRACTOR shall be deemed to be in default of the Agreement and DISTRICT may, without prejudice to any other right or remedy, serve written notice upon CONTRACTOR and its surety of DISTRICT's intention to terminate this Agreement, such notice to contain the reasons for such intention to terminate, and unless within ten (10) calendar days after the service of such notice such condition shall cease or such violation shall cease, or arrangements satisfactory to DISTRICT for the correction thereof be made and corrective action commenced in a diligent and workmanlike manner and pursued to satisfactory completion, this Agreement shall upon the expiration of said ten (10) calendar days, cease and terminate. In such case, CONTRACTOR shall be excluded from the worksite and not be entitled to receive any further payment until work is finished to DISTRICT's satisfaction.

(b) In the event of any such termination, surety shall have the right to take over and perform this Agreement, provided, however, that if surety within five (5) calendar days after service upon it of said notice of termination does not give DISTRICT written notice of its intention to take over and perform this Agreement or does not commence performance thereof within ten (10) calendar days after date of serving such notice of termination by DISTRICT on surety, DISTRICT may take over the work and prosecute same to completion by any means determined by DISTRICT including hiring another contractor for the account and at the expense of CONTRACTOR, and CONTRACTOR and its surety shall be liable to DISTRICT for any excess cost or other damages occasioned by the DISTRICT thereby. Time is of the essence in this Agreement. If the DISTRICT takes over the work as hereinabove provided, the DISTRICT may, without liability for so doing, take possession of and utilize in completing the work such materials, supplies, equipment and other property belonging to the CONTRACTOR as may be on the site of the work and necessary therefore.

(c) The expense of finishing the work, including compensation for additional architectural, managerial, and administrative services, shall be a charge against CONTRACTOR and CONTRACTOR agrees that the charge may be deducted from any money due or becoming due to CONTRACTOR from DISTRICT or CONTRACTOR shall pay the charge to the DISTRICT. Expense incurred by DISTRICT as herein provided, and damage incurred through CONTRACTOR's default, shall be certified to DISTRICT by ARCHITECT. The surety shall become liable for payment should CONTRACTOR fail to pay in full any cost incurred by the DISTRICT.

(d) Nonappropriation of Funds/Insufficient Funds. In the event that sufficient funds are not appropriated to complete the Project or the DISTRICT determines that sufficient funds are not available to complete the Project, DISTRICT may terminate or suspend the completion of the Project at any time by giving written notice to the CONTRACTOR. In the event that the DISTRICT exercises this option, the DISTRICT shall pay for any and all work and materials completed or delivered onto the site, and the value of any and all work then in progress and orders actually placed which cannot be canceled up to the date of notice of termination. The value of work and materials paid for shall include a factor of fifteen percent (15%) for the CONTRACTOR's overhead and profit and there shall be no other costs or expenses paid to CONTRACTOR. All work, materials and orders paid for pursuant to this provision shall become the property of the DISTRICT. DISTRICT may, without cause, order CONTRACTOR in writing to suspend, delay or interrupt the Project in whole or in part for such period of time as DISTRICT may determine. Adjustment shall be made for increases in the cost of performance of the Agreement caused by suspense, delay or interruption.

(e) The foregoing provisions are in addition to and not a limitation of any other rights or remedies available to the DISTRICT.



## ARTICLE 14. BONDS

Unless otherwise specified in Special Conditions, CONTRACTOR shall furnish a surety bond in an amount equal to one hundred percent (100%) of contract price as security for faithful performance of this Agreement and shall furnish a separate bond in an amount of one hundred percent (100%) of the contract price as security for payment to persons performing labor and furnishing materials in connection with this Project. Bonds shall be in the form set forth in these Project Documents.

## ARTICLE 15. SUBSTITUTION OF SECURITIES

(a) Pursuant to the requirements of Public Contract Code Section 22300, upon CONTRACTOR's request, DISTRICT will make payment to CONTRACTOR of any earned retention funds withheld from payments under this Agreement if CONTRACTOR deposits with the DISTRICT or in escrow with a California or federally chartered bank acceptable to DISTRICT, securities eligible for the investment pursuant to Government Code Section 16430 or bank or savings and loan certificates of deposit, upon the following conditions:

(1) CONTRACTOR shall be the beneficial owner of any securities substituted for retention funds withheld and shall receive any interest thereon.

(2) All expenses relating to the substitution of securities under said Section 22300 and under this Article 15, including, but not limited to DISTRICT's overhead and administrative expenses, and expenses of escrow agent shall be the responsibility of the CONTRACTOR.

(3) If CONTRACTOR shall choose to enter into an escrow agreement, such agreement shall be in the form as set forth in Public Contract Code section 22300(f) attached hereto as part of the Project Documents and which shall allow for the conversion to cash to provide funds to meet defaults by the CONTRACTOR including, but not limited to, termination of the CONTRACTOR's control over the work, stop notices filed pursuant to law, assessment of liquidated damages or amount to be kept or retained under the provisions of the Project Documents.

(4) Securities, if any, shall be returned to CONTRACTOR only upon satisfactory completion of the Agreement.

(b) To minimize the expense caused by such substitution of securities, CONTRACTOR shall, prior to or at the time CONTRACTOR requests to substitute security, deposit sufficient security to cover the entire amount to be then withheld and to be withheld under the General Conditions of this Agreement . Should the value of such substituted security at any time fall below the amount for which it was substituted, or any other amount which the DISTRICT determines to withhold, CONTRACTOR shall immediately, and at CONTRACTOR's expense, deposit additional security qualifying

under said Section 22300 until the total security deposited is no less than equivalent to the amount subject to withholding under the Agreement.

(c) In the alternative, under Section 22300, CONTRACTOR, at its own expense, may request DISTRICT to make payment of earned retention funds directly to the escrow agent. Also at the expense of CONTRACTOR, CONTRACTOR may direct investment of the payments into securities, and CONTRACTOR shall receive the interest earned on the investment upon the same conditions as shown in paragraph (a) for securities deposited by CONTRACTOR. Upon satisfactory completion of the Agreement, CONTRACTOR shall receive from the escrow agent all securities, interest and payments received by the escrow agent from DISTRICT, pursuant to the terms of Section 22300.

(d) If any provision of this Article 15 shall be found to be illegal or unenforceable, then, notwithstanding, this Article 15 shall remain in full force and effect, and such provision shall be deemed stricken.

#### ARTICLE 16. FIRE INSURANCE

CONTRACTOR will procure at CONTRACTOR's own expense, and before commencement of any work under this Agreement, fire insurance on the Project. Amount of fire insurance shall be sufficient to protect against loss or damage in full until work is accepted by DISTRICT. CONTRACTOR shall submit proof of insurance and shall provide endorsements on forms provided by the DISTRICT or on forms approved by the DISTRICT.

#### ARTICLE 17. PUBLIC LIABILITY AND PROPERTY DAMAGE INSURANCE

(a) CONTRACTOR shall take out and maintain during the life of this Agreement such public liability and property damage insurance as shall protect CONTRACTOR and DISTRICT from all claims for personal injury, including accidental death, to any person (including, as to DISTRICT, injury or death to CONTRACTOR's or subcontractor's employees), as well as from all claims for property damage arising from operations under this Agreement, in amounts as set forth in the Agreement.

(b) CONTRACTOR shall require its subcontractors, if any, to take out and maintain similar public liability and property damage insurance in like amounts or insure the activities of its subcontractors in CONTRACTOR's own policy.

(c) CONTRACTOR, during the progress of the work and until final acceptance of the work by DISTRICT upon completion of the entire Agreement, shall maintain Builder's Risk/ "All Risk," course-of-construction insurance in an amount not less than as set forth in the Agreement. Coverage is to provide extended coverage and insurance against vandalism, malicious mischief, perils of fire, sprinkler leakage, civil authority, sonic boom, earthquake, collapse, flood, wind, lightning, smoke, riot, debris removal (including demolition), and reasonable compensation for ARCHITECT's services and expenses required as a result of such insured loss upon the entire work which is the subject of the

Project Documents, including completed work and work in progress to the full insurable amount thereof. The risk of damage to the work due to the perils covered by the Builder's Risk/"All Risk" Insurance, as well as any other hazards which might result in damage to the work, is that of CONTRACTOR and the surety, and no claims for such loss or damage shall be recognized by DISTRICT nor will such loss or damage excuse the complete and satisfactory performance of the Agreement by CONTRACTOR.

(d) CONTRACTOR shall submit proof of insurance and shall provide endorsements on the forms provided by the DISTRICT or on forms approved by the DISTRICT. Such insurance shall be issued by admitted surety insurers under the same conditions as required for bonds on the Project.

#### ARTICLE 18. WORKERS' COMPENSATION INSURANCE

(a) In accordance with the provisions of Section 3700 of the Labor Code, the CONTRACTOR and every subcontractor shall be required to secure the payment of compensation to its employees.

(b) The CONTRACTOR shall provide, during the life of the Agreement, workers' compensation insurance for all of its employees engaged in work under this Agreement, on or at the site of the Project, and, in case any of its work is sublet, the CONTRACTOR shall require the subcontractor similarly to provide workers' compensation insurance for all the latter's employees. Any class of employee or employees not covered by a subcontractor's insurance shall be covered by the CONTRACTOR's insurance. In case any class of employees engaged in work under this Agreement, on or at the site of the Project, is not protected under the workers' compensation statute, the CONTRACTOR shall provide or shall cause a subcontractor to provide, adequate insurance coverage for the protection of such employees not otherwise protected before subcontractor commences work. The CONTRACTOR shall file with the DISTRICT certificates of its insurance protecting workers and a thirty (30) day notice shall be provided to DISTRICT before the cancellation or reduction of any policy of CONTRACTOR or subcontractor. CONTRACTOR shall submit proof of insurance and shall provide endorsements on the forms provided by the DISTRICT or on forms approved by the DISTRICT. Such endorsements shall be submitted concurrently with the Project Documents.

#### ARTICLE 19. PROOF OF CARRIAGE OF INSURANCE

(a) CONTRACTOR shall not commence work nor shall it allow any subcontractor to commence work under this Agreement until all required insurance certificates and endorsements from admitted surety insurers have been obtained and delivered in duplicate to and approved by DISTRICT. Such insurance shall be issued by admitted surety insurers under the same conditions as required for bonds on the Project. CONTRACTOR shall provide proof of insurance on DISTRICT approved forms without revisions.

(b) Certificates and insurance policies shall include the following:

(1) A clause stating:

"This policy shall not be canceled or reduced in required limits of liability or amount of insurance until notice has been mailed to DISTRICT stating date of cancellation or reduction. Date of cancellation or reduction may not be less than thirty (30) days after date of mailing notice."

(2) Language stating in particular those insured, extent of insurance, location and operation to which insurance applies, expiration date, to whom cancellation and reduction notice will be sent, and length of notice period.

(3) Statement that the DISTRICT is an additional insured under the policy described and that such insurance policy shall be primary to any insurance or self-insurance maintained by the DISTRICT.

(c) In case of CONTRACTOR's failure to provide insurance as required by the Agreement, the DISTRICT may, at DISTRICT's option, take out and maintain at the expense of the CONTRACTOR, such insurance in the name of CONTRACTOR, or subcontractor, as the DISTRICT may deem proper and may deduct the cost of taking out and maintaining such insurance from any sums which are due or to become due to the CONTRACTOR under this Agreement.

## ARTICLE 20. DRAWINGS AND SPECIFICATIONS

(a) Drawings and Specifications are intended to delineate and describe the Project and its component parts to such a degree as will enable skilled and competent contractors to intelligently bid upon the work, and to carry said work to a successful conclusion.

(b) Drawings and Specifications are intended to comply with all laws, ordinances, rules and regulations of constituted authorities having jurisdiction, and where referred to in the Project Documents, said laws, ordinances, rules and regulations shall be considered as a part of the Agreement within the limits specified. The CONTRACTOR shall bear all expenses of correcting work done contrary to said laws, ordinances, rules and regulations and if the CONTRACTOR performed same (1) without first consulting the ARCHITECT for further instructions regarding said work, or (2) disregarded the ARCHITECT'S instructions regarding said work.

(c) Questions regarding interpretation of drawings and specifications shall be clarified by the ARCHITECT. Before commencing any portion of the work, CONTRACTOR shall carefully examine all drawings and specifications and other information given to CONTRACTOR. CONTRACTOR shall immediately notify ARCHITECT and DISTRICT in writing of any perceived or alleged error, inconsistency, ambiguity, or lack of detail or explanation in the drawings and specifications. If CONTRACTOR or its subcontractors, material or equipment suppliers, or any of their officers, agents, and employees performs, permits, or causes the performance of any work under the Project Documents, which it knows or should have known to be in error, inconsistent, or

ambiguous, or not sufficiently detailed or explained, CONTRACTOR shall bear any and all costs arising therefrom including, without limitation, the cost of correction thereof. In the event ARCHITECT determines that CONTRACTOR's requests for clarification or interpretation are not justified or do not reflect adequate competent supervision or knowledge by the CONTRACTOR or his/her subcontractors, CONTRACTOR shall be required to pay ARCHITECT's reasonable and customary fees in processing and responding to such requests. Should the CONTRACTOR commence work or any part thereof without seeking clarification, CONTRACTOR waives any claim for extra work or damages as a result of any ambiguity, conflict or lack of information.

(d) Figured dimensions on drawings shall govern, but work not dimensioned shall be as directed. Work not particularly shown or specified shall be the same as similar parts that are shown or specified. Large scale drawings shall take precedence over smaller scale drawings as to shape and details of construction. Specifications shall govern as to materials, workmanship, and installation procedures. Drawings and specifications are intended to be fully cooperative and to agree. If CONTRACTOR observes that drawings and specifications are in conflict, CONTRACTOR shall promptly notify the ARCHITECT in writing, and any necessary changes shall be adjusted as provided in the Article entitled "Changes and Extra Work;" provided, however, that the specification calling for the higher quality material or workmanship shall prevail without additional cost to DISTRICT.

(e) Materials or work described in words which so applied has a well-known technical or trade meaning shall be deemed to refer to such recognized standards.

(f) It is not the intention of the Agreement to go into detailed descriptions of any materials and/or methods commonly known to the trade under "trade name" or "trade term." The mere mention or notation of such "trade name" or "trade term" shall be considered a sufficient notice to CONTRACTOR that it will be required to complete the work so named with all its incidental and accessory items according to the best practices of the trade.

(g) The naming of any material and/or equipment shall mean furnishing and installing of same, including all incidental and accessory items thereto and/or labor necessary to achieve full and complete functioning of the material and/or equipment as per best practices of the trade(s) involved, unless specifically noted otherwise.

(h) ARCHITECT will furnish to CONTRACTOR one (1) complete set of blue-line prints for posting of changes. Additional blue-line prints shall be provided by ARCHITECT upon payment by CONTRACTOR. During the construction period, CONTRACTOR shall maintain the set of blue-line prints in a satisfactory record condition, and shall thoroughly and neatly post, as they occur, all additions, deletions, corrections and/or revisions in the actual construction of the Project. The record drawings must be posted monthly and be current prior to each submission of each certificate of payment.

## ARTICLE 21. OWNERSHIP OF DRAWINGS

All plans, drawings, designs, specifications, and other incidental architectural and engineering work or materials and other Project Documents and copies thereof furnished by DISTRICT are DISTRICT'S property. They are not to be used in other work and are to be returned to DISTRICT on request at completion of work, and may be used by DISTRICT as it may require, without any additional costs to DISTRICT.

## ARTICLE 22. DETAIL DRAWINGS AND INSTRUCTIONS

(a) In case of ambiguity, conflict, or lack of information, ARCHITECT shall furnish additional instructions by means of drawings or otherwise, necessary for proper execution of work. All such drawings and instructions shall be consistent with Project Documents, true developments thereof, and reasonably inferable therefrom. Such additional instructions shall be furnished with reasonable promptness, provided that CONTRACTOR informs the ARCHITECT of the relationship of the request to the critical path of construction.

(b) Work shall be executed in conformity therewith and CONTRACTOR shall do no work without proper drawings and instructions.

(c) The ARCHITECT will furnish necessary additional details to more fully explain the work, which details shall be considered as part of the Project Documents.

(d) Should any details be more elaborate, in the opinion of the CONTRACTOR, than scale drawings and specifications warrant, CONTRACTOR shall give written notice thereof to the ARCHITECT within five (5) days of the receipt of same. In case no notice is given to the ARCHITECT within five (5) days, it will be assumed the details are reasonable development of the scale drawings. In case notice is given, then it will be considered, and if found justified, the ARCHITECT will either modify the drawings or shall recommend to DISTRICT a change order for the extra work involved.

(e) All parts of the described and shown construction shall be of the best quality of their respective kinds and the CONTRACTOR is hereby advised to use all diligence to become fully involved as to the required construction and finish, and in no case to proceed with the different parts of the work without obtaining first from the ARCHITECT such directions and/or drawings as may be necessary for the proper performance of the work.

(f) If it is found at any time, before or after completion of the work, that the CONTRACTOR has varied from the drawings and/or specifications, in materials, quality, form or finish, or in the amount or value of the materials and labor used, the ARCHITECT shall make a recommendation: (1) that all such improper work should be removed, remade and replaced, and all work disturbed by these changes be made good at the CONTRACTOR's expense; or (2) that the DISTRICT deduct from any amount due CONTRACTOR, the sum of money equivalent to the difference in value between the work performed and that called for by the drawings and specifications. ARCHITECT shall

determine such difference in value. The DISTRICT, at its option, may pursue either recommendation made by the ARCHITECT.

### ARTICLE 23. SHOP DRAWINGS

(a) CONTRACTOR shall check and verify all field measurements and shall submit to ARCHITECT within \_\_\_\_ ( ) calendar days of the date specified on the Notice to Proceed \_\_\_\_ ( ) copies, checked and approved by CONTRACTOR, of all shop or setting list drawings, schedules, and materials list required for the work of various trades. ARCHITECT shall review such drawings, schedules and materials list only for conformance with design concept of Project and compliance with information given in Project Documents, and return as approved or disapproved with guidance as to required corrections within \_\_\_\_ ( ) calendar days. CONTRACTOR shall make any corrections required by ARCHITECT, file three (3) corrected copies with ARCHITECT, and furnish such other copies as may be needed for construction within \_\_\_\_ ( ) calendar days. ARCHITECT'S approval of such drawings, schedules, or materials list shall not relieve CONTRACTOR from responsibility for deviations unless CONTRACTOR has in writing called ARCHITECT'S attention to such deviations at time of submission and secured ARCHITECT'S written approval, nor shall it relieve CONTRACTOR from responsibility for errors in shop drawings or schedules.

(b) All submittals of shop drawings, catalog cuts, data sheets, schedules and material lists shall be complete and shall conform to contract drawings and specifications.

(c) The term "shop drawing" as used herein shall be understood to include, but not be limited to, detail design calculations, fabrication and installation drawings, lists, graphs and operating instructions.

(d) Shop drawings shall be submitted at a time sufficiently early to allow review of same by the Division of State Architect (DSA) if required, and the ARCHITECT, and to accommodate the rate of construction progress required under the Project Documents. CONTRACTOR will be required to pay ARCHITECT's reasonable and customary fees in order to expedite review of shop drawings which are not submitted in a timely fashion.

(e) All shop drawing submittals shall be accompanied by an accurately completed transmittal form using the format bound herein. Any shop drawing submittal not accompanied by such a form, or where all applicable items on the form are not completed, will be returned for resubmittal. The CONTRACTOR may authorize a material or equipment supplier to deal directly with the ARCHITECT with regard to shop drawings, however, ultimate responsibility for the accuracy and completeness of the information contained in the submittal shall remain with the CONTRACTOR.

(f) Normally, a separate transmittal form shall be used for each specific item or class of material or equipment for which a submittal is required. Transmittal of shop drawings on various items using a single transmittal form will be permitted only when the items taken together constitute a manufacturer's "package" or are so functionally related that

expediency indicates review of the group or package as a whole. At its option, the CONTRACTOR or Supplier may obtain from the ARCHITECT quantities of the shop drawing transmittal form at reproduction cost.

(g) CONTRACTOR's review and approval of shop drawings shall include the following stamp:

"The CONTRACTOR has reviewed and approved not only the field dimensions but the construction criteria and has also made written notation regarding any information in the shop drawings that does not conform to the Project Documents. This shop drawing has been coordinated with all other shop drawings received to date by CONTRACTOR and this duty of coordination has not been delegated to subcontractors, material suppliers, the ARCHITECT, or the engineers on this project.

---

Signature of CONTRACTOR"

(h) Within \_\_\_\_\_ ( ) calendar days after receipt of shop drawings, the ARCHITECT will return one or more prints of each drawing to CONTRACTOR with his or her comments noted thereon. The CONTRACTOR shall make a complete and acceptable submittal to the ARCHITECT by the second submission of drawings. The DISTRICT shall withhold funds due the CONTRACTOR to cover additional costs of the ARCHITECT'S review beyond the second submission and any other costs incurred by DISTRICT.

(i) If prints of the shop drawing are returned to the CONTRACTOR marked "NO EXCEPTIONS TAKEN," formal revision of said drawing will not be required. If prints of the drawing are returned to the CONTRACTOR marked "MAKE CORRECTIONS NOTED," formal resubmittal of said drawings will not be required. If prints of the drawing are returned to the CONTRACTOR marked "REVISE AND RESUBMIT," the CONTRACTOR shall revise said drawing and shall resubmit six (6) copies of the revised drawing to the ARCHITECT. If prints of the drawing are returned to the CONTRACTOR marked "REJECTED RESUBMIT," the CONTRACTOR shall resubmit six (6) new copies of the drawing to the ARCHITECT.

(j) Fabrication of an item shall not be commenced before the ARCHITECT has reviewed the pertinent shop drawings and returned copies to the CONTRACTOR marked with "NO EXCEPTIONS TAKEN," or "MAKE CORRECTIONS NOTED." Revisions indicated on shop drawings shall be considered as changes necessary to meet the requirements of the Project Documents and shall not be taken as the basis of claims for extra work. The review of such drawings by the ARCHITECT will be limited to checking for general agreement with the Project Documents, and shall in no way relieve the CONTRACTOR of responsibility for errors or omissions contained therein, nor shall such



review operate to waive or modify any provision contained in the Project Documents. Fabricating dimensions, quantities of material, applicable code requirements, and other contract requirements shall be the CONTRACTOR's responsibility.

(k) No work represented by required shop drawings shall be purchased or commenced until the applicable submittal has been approved. The work shall conform to the approved shop drawings and all other requirements of the Project Documents. The CONTRACTOR shall not proceed with any related work which may be affected by the work covered under shop drawings until the applicable shop drawings have been approved, particularly where piping, machinery, and equipment and the required arrangements and clearances are involved.

(l) Except where the preparation of a shop drawing is dependent upon the approval of a prior shop drawing, all shop drawings pertaining to the same class or portion of the work shall be submitted simultaneously.

(m) Calculations of a structural nature must be approved by the Division of State Architect.

(n) THE CONTRACTOR SHALL HAVE NO CLAIM FOR DAMAGES OR EXTENSION OF TIME DUE TO ANY DELAY RESULTING FROM THE CONTRACTOR HAVING TO MAKE THE REQUIRED REVISIONS TO SHOP DRAWINGS UNLESS REVIEW BY THE ARCHITECT OF SAID DRAWINGS IS DELAYED BEYOND THE TIME PROVIDED HEREINBEFORE AND THE CONTRACTOR CAN ESTABLISH THAT THE ARCHITECT'S DELAY IN REVIEW ACTUALLY RESULTED IN A DELAY IN THE CONTRACTOR CONSTRUCTION SCHEDULE. CONTRACTOR SHALL NOT BE ENTITLED TO ANY CLAIM FOR DAMAGES RESULTING FROM DSA REVIEW EXTENDING BEYOND FIFTEEN (15) CALENDAR DAYS AFTER SUBMITTAL. HOWEVER, DISTRICT MAY CONSIDER AN EXTENSION OF TIME DUE TO ANY DELAY CAUSED BY DSA REVIEW.

#### ARTICLE 24. LAYOUT AND FIELD ENGINEERING

All field engineering required for laying out of this work and establishing grades for earthwork operations shall be furnished by CONTRACTOR at its expense. Such work shall be done by a qualified civil engineer approved by the ARCHITECT. Any required "Record" drawings of site development shall be prepared by the approved civil engineer.

#### ARTICLE 25. SOILS INVESTIGATION REPORT

(a) When a soils investigation report has been obtained from test holes at the site, such report is available for the CONTRACTOR's use in preparing its bid and work under this Agreement. Such report shall not be part of the Agreement. Any information obtained from such report or any information given on drawings as to surface and subsurface soil condition or to elevations of existing grades or elevations of underlying rock is approximate

only, is not guaranteed and does not form a part of the Agreement. CONTRACTOR is required to make a visual examination of site and must make whatever test CONTRACTOR deems appropriate to determine surface and subsurface soil conditions. If, during the course of work under this Agreement, CONTRACTOR encounters subsurface or latent conditions which differ materially from those indicated in the soils investigation report, then CONTRACTOR shall notify the DISTRICT within five (5) working days of discovery of the condition.

**WARNING:** DISTRICT DOES NOT WARRANT THE SOILS AT THE PROJECT SITE NOR ANY INFORMATION CONTAINED IN ANY SOILS REPORT. SOILS INVESTIGATION REPORT IS PROVIDED FOR CONTRACTOR'S INFORMATION ONLY. CONTRACTOR HAS CONDUCTED AN INDEPENDENT INVESTIGATION OF THE PROJECT SITE AND THE SOILS CONDITIONS OF THE SITE. DISTRICT DOES NOT WARRANT THE SOILS CONDITIONS OF THE SITE AND CONTRACTOR IS FULLY RESPONSIBLE TO ASCERTAIN SITE CONDITIONS FOR THE PURPOSES OF DETERMINING CONSTRUCTION MEANS AND METHODS PRIOR TO COMMENCING CONSTRUCTION.

(b) CONTRACTOR agrees that no claim against DISTRICT will be made by CONTRACTOR for damages and hereby waives any rights to damages in the event that during progress of work CONTRACTOR encounters subsurface or latent conditions at the worksite materially different from those shown on drawings or indicated in specifications.

#### ARTICLE 26. TESTS AND INSPECTIONS

(a) Tests and inspections will comply with California Code of Regulations and with all other laws, ordinances, rules, regulations, or orders of public authorities having jurisdiction over the Project.

(b) If the Agreement, DISTRICT's instructions, laws, ordinances, or any public authority require any work to be specially tested or approved, CONTRACTOR shall give notice in accordance with such authority of its readiness for observation or inspection at least two (2) working days prior to being tested or covered up. If inspection is by authority other than DISTRICT, CONTRACTOR shall inform the DISTRICT's Inspector of the date fixed for such inspection. Required certificates of inspection shall be secured by CONTRACTOR. Observations by DISTRICT's Inspector shall be promptly made, and where practicable, at source of supply. If any work should be covered up without approval or consent of DISTRICT's Inspector, it must be uncovered for examination and satisfactorily reconstructed at CONTRACTOR's expense in compliance with the Agreement. Costs of tests, inspections and any materials found to be not in compliance with the Agreement shall be paid for by CONTRACTOR. Other costs for test and inspection shall be paid by the DISTRICT.

ARTICLE 27. TRENCHES

(a) CONTRACTOR shall provide adequate sheeting, shoring, and bracing, or equivalent method, for the protection of life and limb in trenches and open excavation which conform to applicable safety standards.

(b) If this Agreement involves the excavation of any trench or trenches five (5) feet or more in depth, and the Project cost is in excess of \$25,000, the CONTRACTOR shall, in advance of excavation, submit to the DISTRICT for acceptance or to whomever DISTRICT designates which may include a registered civil or structural engineer employed by the DISTRICT to whom authority to accept has been delegated, a detailed plan showing the design of shoring, bracing, sloping or other provisions to be made for worker protection from the hazard of caving ground during the excavation of such trench or trenches. If such plan varies from the Shoring System Standards established by the Construction Safety Orders of the Division of Industrial Safety, the plan shall be prepared by a registered civil or structural engineer employed by the CONTRACTOR, and all costs therefore shall be included in the price named in the Agreement for completion of the work as set forth in the Project Documents. In no case shall such plan be less effective than that required by the Construction Safety Orders. No excavation of such trench or trenches shall be commenced until said plan has been accepted by CAL-OSHA and a CAL-OSHA permit for such plan delivered to the DISTRICT. Labor Code Section 6500 and 6705; Health and Safety Code Section 17922.5)

(c) If this Agreement involves the digging of trenches or excavations that extend deeper than four feet below the surface, the following shall apply pursuant to Public Contract Code section 7104:

(1) The CONTRACTOR shall promptly, and before the following conditions are disturbed, notify the DISTRICT, in writing, of any:

(i) Material that the CONTRACTOR believes may be material that is hazardous waste, as defined in Section 25117 of the Health and Safety Code, that is required to be removed to a Class I, Class II, or Class III disposal site in accordance with provisions of existing law.

(ii) Subsurface or latent physical conditions at the site different from those indicated.

(iii) Unknown physical conditions at the site of any unusual nature, different materially from those ordinarily encountered and generally recognized as inherent in work of the character provided for in the contract.

(2) The DISTRICT shall promptly investigate the conditions, and if it finds that the conditions do materially so differ, or do involve hazardous waste, and cause a decrease or increase in the CONTRACTOR's cost of, or the time required for,

performance of any part of the work shall issue a change order under the procedures described in the Project Documents.

(3) In the event a dispute arises between the DISTRICT and the CONTRACTOR, whether the conditions materially differ or involve hazardous waste, or cause a decrease or increase in the CONTRACTOR's cost of, or time required for, performance of any part of the work, the CONTRACTOR shall not be excused from any scheduled completion date provided for by the Project Documents, but shall proceed with all the work to be performed under the Project Documents. The CONTRACTOR shall retain any and all rights provided either by contract or by law which pertain to the resolution of disputes and protests between the contracting parties.

#### ARTICLE 28. DOCUMENTS ON WORK

CONTRACTOR shall keep on the job site at all times one legible copy of all Project Documents, including addenda and change orders, and all approved drawings, plans, schedules and specifications. Said Documents shall be kept in good order and available to ARCHITECT, ARCHITECT's representatives, and all authorities having jurisdiction. CONTRACTOR shall be acquainted with and comply with all California Code of Regulations provisions relating to conditions on this Project.

#### ARTICLE 29. STATE AUDIT

Pursuant to and in accordance with the provisions of Government Code Section 8546.7, or any amendments thereto, all books, records and files of the DISTRICT, the CONTRACTOR, or any subcontractor connected with the performance of this Agreement involving the expenditure of public funds in excess of Ten Thousand Dollars (\$10,000.00), including, but not limited to, the costs of administration of the Agreement, shall be subject to the examination and audit of the State Auditor at the request of the DISTRICT or as part of any audit of the DISTRICT for a period of three (3) years after final payment is made under this Agreement .

#### ARTICLE 30. SUBSTITUTIONS

(a) Prior to Bid Opening. Should the bidder wish to request prior to bid opening, any substitution for the materials, process, service or equipment specified, the bidder shall submit a written request at least ten (10) working days before the bid opening date and hour. If the substituted item is acceptable, the DISTRICT will approve it in an Addendum issued to all bidders of record. Requests received less than ten (10) working days prior to bid opening will not be considered. DISTRICT shall only consider substitution requests from the bidder submitting the bid for the project.

(b) After Bid Opening and Prior to Award of Contract. If the bidder clearly indicates in its bid that it is proposing to use an "equal" product, the brand name or trade name, if any, of a proposed substitute item shall be inserted in the space provided in the bid or shall

be otherwise clearly identified in the bid. If the bidder fails to indicate an "equal" product, its bid shall be considered as offering the material, process, service or equipment referred to by the brand name or trade name specified. It is expressly understood and agreed to by the bidder that the DISTRICT reserves the right to reject any such proposed substituted item. It is further expressly understood and agreed by bidder that in the event the DISTRICT rejects a proposed "equal" item, the bidder will then supply the material, process, service or equipment designated by brand name or trade name or a substitute therefore which meets with the approval of the DISTRICT.

With respect to all proposed substitutions of "equal" items, the bidder shall submit all pertinent and appropriate data substantiating its request for substitutions within \_\_\_\_\_ ( ) days prior to the award of the contract. DISTRICT shall only consider substitution requests from the bidder submitting the bid for the Project. The DISTRICT is not responsible for locating or securing any information which is not included in such substantiating data. The burden of proof as to the quality or suitability of proposed substituted items shall be borne by the bidder. The DISTRICT shall be the sole judge as to the quality and suitability of proposed substituted items, and decisions of the DISTRICT shall be final and conclusive. Unless extended by the mutual agreement of the parties, the DISTRICT shall notify the successful bidder of the decision concerning the proposed substitution of "equal" items prior to the award of the contract. Also such decisions by the DISTRICT shall be in writing, and no proposed substituted item shall be deemed approved unless the DISTRICT has so indicated in writing. These time limitations shall be complied with strictly, and in no case will an extension of time for completion be granted because of the bidder's failure to request the substitution of an item at the times and in the manner set forth herein.

(c) Whenever in specifications any materials, process, service or equipment is indicated or specified by brand name, trade name, proprietary name or by name of manufacturer, such specification shall be deemed to be used for the purpose of facilitating description of material, process, service or equipment desired and shall be deemed to be followed by the words "or equal," and CONTRACTOR may, unless otherwise stated, offer any material, process, service, or equipment which shall be substantially equal or better in every respect to that so indicated or specified subject to DISTRICT or ARCHITECT approval.

(d) If material, process, service, or equipment offered by CONTRACTOR is not, in opinion of ARCHITECT, or DISTRICT, substantially equal or better in every respect to that specified, then CONTRACTOR shall furnish the material, process, service, or equipment specified. Burden of proof as to equality of any material, process, service, or equipment shall rest with CONTRACTOR. Provision authorizing submission of "or equal" substantiating data shall not in any way authorize an extension of time for performance of this Agreement nor shall DISTRICT or ARCHITECT authorize the submission of □or equal□ substantiating data within \_\_\_\_ ( ) days of the filing of the Notice of Completion on the Project.

(e) In the event CONTRACTOR furnishes material, process, service or equipment other than what was specified by the DISTRICT and which has been accepted by the DISTRICT and which later is defective, then CONTRACTOR at its sole cost and expense shall furnish the DISTRICT specified material, process, service or equipment or fully replace with new the defective material process, service or equipment at DISTRICT's discretion.

(f) In the event CONTRACTOR furnishes material, process service, or equipment more expensive than that specified, difference in cost of such material, process, service, or equipment so furnished shall be borne by CONTRACTOR. Any engineering, design fees, or approval agencies' fees required to make adjustments in material or work of all trades directly or indirectly affected by the approved substituted items shall be borne entirely by CONTRACTOR. Any difference in cost between an approved substitution which is lower in cost than the originally specified item shall be refunded or credited by CONTRACTOR to DISTRICT.

(g) Price, fitness and quality being equal with regard to supplies, the District may prefer supplies grown, manufactured, or produced in California and next prefer supplies partially manufactured grown, or produced in California provided the bids of said suppliers or the prices quoted by them do not exceed by more than 5% of the lowest bids/prices quoted by out of state suppliers, the major portion of the manufacture of the supplies is not done outside of California and the public good will be served thereby. (Government Code section 4330-4334)

#### ARTICLE 31. SAMPLES

(a) CONTRACTOR shall furnish for approval, within thirty-five (35) calendar days following award of contract, all samples as required in specifications together with catalogs and supporting data required by ARCHITECT. This provision shall not authorize any extension of time for performance of the work. ARCHITECT shall review such samples, as to conformance with design concept of work and for compliance with information given in Project Documents and approve or disapprove same within ten (10) working days from receipt of same.

(b) Unless specified otherwise, sampling, preparation of samples and tests shall be in accordance with the latest standards of the American Society for Testing and Materials.

(c) Samples shall, upon demand of ARCHITECT or DISTRICT, be submitted for tests or examinations and considered before incorporation of same into the work. CONTRACTOR shall be solely responsible for delays due to samples not being submitted in time to allow for tests. Acceptance or rejection will be expressed in writing. Work shall be equal to approved samples in every respect. Samples which are of value after testing will remain the property of the CONTRACTOR.

## ARTICLE 32. PROGRESS SCHEDULE

- (a) Within five (5) calendar days after being awarded the contract, CONTRACTOR shall submit a progress schedule for DISTRICT's approval. The schedule shall indicate the beginning and completion dates of all phases of construction and shall use the "critical path method" (commonly called CPM) or equivalent scheduling methodology for the value reporting, planning and scheduling, of all work required under the Project Documents. The schedule will separately identify those milestones or events that must be completed before other portions of the work can be accomplished.
- (b) The scheduling is necessary for the DISTRICT's adequate monitoring of the progress of the work and shall be prepared in accordance with the time frame described in Article 4 of the Agreement. The DISTRICT may disapprove such a schedule and require modification to it if, in the opinion of the ARCHITECT or DISTRICT, adherence to the progress schedule will cause the work not to be completed in accordance with the Agreement. CONTRACTOR shall adhere to any such modifications required by the DISTRICT.
- (c) CONTRACTOR will exchange scheduling information with subcontractors and suppliers. CONTRACTOR will order work, equipment and materials with sufficient lead time to avoid interruption of the work.
- (d) The CONTRACTOR shall submit to DISTRICT a monthly schedule to reflect the actual sequence of the work which shall be totally separate and apart from the original progress schedule.
- (e) The CONTRACTOR shall also, if requested by the ARCHITECT or DISTRICT, provide revised schedules within ten (10) calendar days if, at any time, the ARCHITECT or DISTRICT, consider the completion date to be in jeopardy. The revised schedule shall be designed to show how the CONTRACTOR intends to accomplish the work to meet the original completion date. The form and method employed by the CONTRACTOR shall be the same as for the original progress schedule. The CONTRACTOR shall modify any portions of the schedule that become infeasible because of "activities behind schedule" or for any other valid reason. CONTRACTOR will provide documents and justification for any schedule changes. An activity that cannot be completed by its original completion date shall be deemed to be behind schedule.
- (f) CONTRACTOR shall submit a revised schedule within ten (10) consecutive calendar days of CONTRACTOR's request for any extension of time. Failure to submit such schedule will result in CONTRACTOR waiving his/her right to obtain any extension of time.
- (g) IT IS AGREED THAT THE DISTRICT OWNS THE "FLOAT" ON THIS PROJECT. IF CONTRACTOR SUBMITS A REVISED SCHEDULE SHOWING AN EARLIER COMPLETION DATE FOR THE PROJECT, DISTRICT's ACCEPTANCE OF THIS REVISED SCHEDULE SHALL NOT ENTITLE CONTRACTOR TO ANY

DELAY CLAIM OR DISRUPTION DAMAGES OR ANY OTHER DAMAGES DUE TO ANY SUCH REVISED SCHEDULE. NOTHING PROVIDED HEREIN SHALL BE CONSTRUED AS A DIRECT, INDIRECT OR IMPLICIT ACCELERATION ORDER TO THE CONTRACTOR.

(h) CONTRACTOR agrees that failure to timely submit the progress schedule, the monthly schedule or any revised progress schedule requested by the ARCHITECT or the DISTRICT may result in delay in payment to CONTRACTOR.

### ARTICLE 33. MATERIALS AND WORK

(a) Except as otherwise specifically stated in this Agreement, CONTRACTOR shall provide and pay for all materials, supplies, tools, equipment, labor transportation, superintendence, temporary constructions of every nature, and all other services and facilities of every nature whatsoever necessary to execute and complete the Project within specified time.

(b) Unless otherwise specified, all materials shall be new and the best of their respective kinds and grades as noted or specified, and workmanship shall be of good quality.

(c) Materials shall be furnished in ample quantities and at such times as to insure uninterrupted progress of work and shall be stored properly and protected as required. DISTRICT has no obligation to pay for any prefabricated material stored offsite until delivered and installed to the jobsite and inspected and approved by the inspector of record.

(d) CONTRACTOR shall, after issuance of the Notice to Proceed by DISTRICT, place orders for materials and/or equipment as specified so that delivery of same may be made without delays to the work. CONTRACTOR shall, upon demand from the ARCHITECT, furnish to the ARCHITECT documentary evidence showing that orders have been placed.

(e) DISTRICT reserves the right, for any neglect in not complying with the above instructions, to place orders for such materials and/or equipment as it may deem advisable in order that the work may be completed at the date specified in the Agreement, and all expenses incidental to the procuring of said materials and/or equipment shall be paid for by the CONTRACTOR.

(f) No materials, supplies, or equipment for work under this Agreement shall be purchased subject to any chattel mortgage or under a conditional sale or other agreement by which an interest therein or in any part thereof is retained by seller or supplier. CONTRACTOR warrants good title to all material, supplies, and equipment installed or incorporated in work and agrees upon completion of all work to deliver premises, together with all improvements and appurtenances constructed or placed thereon by it, to DISTRICT free from any claims, liens, or charges. CONTRACTOR further agrees that neither it nor any person, firm, or corporation furnishing any materials or labor for any work covered by this Agreement shall have any right to lien upon premises or any



improvement or appurtenance thereon, except that CONTRACTOR may install metering devices or other equipment of utility companies or of political subdivisions, title to which is commonly retained by utility company or political subdivision. In the event of installation of any such metering device or equipment, CONTRACTOR shall advise DISTRICT as to owner thereof.

(g) Nothing contained in this Article 33, however, shall defeat or impair the rights of persons furnishing material or labor under any bond given by CONTRACTOR for their protection or any rights under any law permitting such persons to look to funds due CONTRACTOR in hand of DISTRICT, and this provision shall be inserted in all subcontracts and material contracts and notice of its provisions shall be given to all persons furnishing materials or labor when no formal contract is entered into for such materials or labor.

(h) The title to new materials and/or equipment and attendant liability for its protection and safety, shall remain in the CONTRACTOR until incorporated in the work and accepted by the DISTRICT; no part of said materials and/or equipment shall be removed from its place of onsite/offsite storage except for immediate installation in the work; and CONTRACTOR shall keep an accurate inventory of all said materials and/or equipment in a manner satisfactory to the DISTRICT or its authorized representative.

#### ARTICLE 34. INTEGRATION OF WORK

(a) CONTRACTOR shall do all cutting, fitting, patching, and preparation of work as required to make its several parts come together properly, and fit it to receive or be received by work of other contractors or existing conditions showing upon, or reasonably implied by, the drawings and specifications, and shall follow all directions given by the Architect.

(b) All costs caused by defective or ill-timed work shall be borne by CONTRACTOR.

(c) CONTRACTOR shall not endanger any work by cutting, excavating, or otherwise altering work and shall not cut or alter work of any other contractor without the written consent of the ARCHITECT. CONTRACTOR shall be solely responsible for protecting existing work on adjacent properties and shall obtain all required permits for shoring and excavations near property lines.

(d) When modifying existing work or installing new work adjacent to existing work, CONTRACTOR shall match, as closely as conditions of site and materials will allow, the finishes, textures, and colors of the original work, refinishing existing work as required, at no additional cost to DISTRICT.

(e) CONTRACTOR is aware that this Project may be split into several phases. If the Project is split into phases then CONTRACTOR has made allowances for any delays or damages which may arise from coordination with contractors for other phases. If any delays should arise from a contractor working on a different phase, CONTRACTOR's sole remedy for damages, including delay damages, shall be against the contractor who caused

such damage and not the DISTRICT. CONTRACTOR shall provide access to contractors for other phases as necessary to prevent delays and damages to contractors working on other phases of construction.

#### ARTICLE 35. OBTAINING OF PERMITS, LICENSES AND EASEMENTS

- (a) Permits, licenses, and certificates necessary for prosecution of work, shall be secured and paid for by CONTRACTOR, unless otherwise specified. All such permits, licenses, and certificates shall be delivered to the ARCHITECT before demand is made for the certificate of final payment. CONTRACTOR shall, and shall require subcontractors to, maintain contractors' licenses in effect as required by law.
- (b) Easements for permanent structures or permanent changes in existing facilities shall be secured and paid for by DISTRICT, unless otherwise specified.
- (c) Permits and charges for installation, and inspection thereof, of utility services by serving utilities shall be secured and paid for by DISTRICT.

#### ARTICLE 36. SURVEYS

Surveys to determine location of property lines and corners will be supplied by DISTRICT. Surveys to determine locations of construction, grading, and site work, shall be provided by CONTRACTOR.

#### ARTICLE 37. EXISTING UTILITY LINES; REMOVAL, RESTORATION

- (a) Pursuant to Government Code Section 4215, the DISTRICT assumes the responsibility for removal, relocation, and protection of utilities located on the construction site at the time of commencement of construction under this Agreement with respect to any such utility facilities which are not identified in the plans and specifications. The CONTRACTOR shall not be assessed for liquidated damages for delay in completion of the Project caused by failure of the DISTRICT to provide for removal or relocation of such utility facilities. If the CONTRACTOR, while performing work under this Agreement, discovers utility facilities not identified by the DISTRICT in the plans or specifications, CONTRACTOR shall immediately notify the DISTRICT and the utility in writing. CONTRACTOR shall be compensated according to the provisions governing changes in the work.
- (b) This Article 37 shall not be construed to preclude assessment against the CONTRACTOR for any other delays in completion of the work. Nothing in this Article shall be deemed to require the DISTRICT to indicate the presence of existing service laterals or appurtenances whenever the presence of such utilities on the construction site can be inferred from the presence of other visible facilities, such as buildings, meter junction boxes, on or adjacent to the site of the construction.

(c) As part of the work to be performed, CONTRACTOR shall provide the notices and proceed in accordance with Government Code Sections 4216.2, 4216.3 and 4216.4, and pay all fees charged pursuant to Government Code Section 4216, et seq.

#### ARTICLE 38. WORK TO COMPLY WITH APPLICABLE LAWS AND REGULATIONS

(a) CONTRACTOR shall give all notices and comply with all laws, ordinances, rules, and regulations applicable to the work as indicated and specified.

(b) If CONTRACTOR observes that drawings or specifications are at variance therewith, CONTRACTOR shall promptly notify ARCHITECT in writing and any changes deemed necessary by the ARCHITECT shall be adjusted as provided for changes in work. If CONTRACTOR performs any work which it knew, or through exercise of reasonable care should have known, to be contrary to such laws, ordinances, rules or regulations, and without such notice to ARCHITECT, CONTRACTOR shall bear all costs arising therefrom. Where plans, drawings or specifications state that materials, processes, or procedures must be approved by the Division of State Architect, State Fire Marshall, or other body or agency, CONTRACTOR shall be responsible for satisfying requirements of such bodies or agencies.

#### ARTICLE 39. ACCESS TO WORK

DISTRICT and its representatives shall at all times have access to work wherever it is in preparation or progress. CONTRACTOR shall provide safe and proper facilities for such access so that DISTRICT's representatives may perform their functions.

#### ARTICLE 40. PAYMENTS BY CONTRACTOR

CONTRACTOR shall pay:

(1) For all transportation and utility services not later than the 20th day of the calendar month following that in which such services are rendered;

(2) For all materials, tools, and other expendable equipment to the extent of ninety percent (90%) of cost thereof, not later than the 20th day of the calendar month following that in which such materials, tools, and equipment are delivered at site of Project and balance of cost thereof not later than the 30th day following completion of that part of work in or on which such materials, tools, and equipment are incorporated or used; and

(3) To each of its subcontractors, not later than the 5th day following each payment to CONTRACTOR the respective amounts allowed CONTRACTOR on account of work performed by respective subcontractor to the extent of such subcontractor's interest therein.

(4) Within seven (7) days from the time that all or any portion of the retentions are received by CONTRACTOR from DISTRICT, to each of its subcontractors from whom retention has been withheld, each subcontractor's share of the retention received. However, if a retention payment received by CONTRACTOR is specifically designated for a particular subcontractor, payment of the retention shall be made to the designated subcontractor, if the payment is consistent with the terms of the subcontract. CONTRACTOR may withhold from a subcontractor its portion of the retentions if a bona fide dispute exists between the subcontractor and the CONTRACTOR. The amount withheld from the retention shall not exceed one hundred fifty percent (150%) of the estimated value of the disputed amount.

#### ARTICLE 41. INSPECTOR'S FIELD OFFICE

CONTRACTOR shall provide for the exclusive use of Inspector a temporary field office to be located as directed by Inspector and to be maintained until removal is authorized by DISTRICT. Office shall be of substantial waterproof construction with adequate natural light and ventilation by means of stock design windows. Door shall have a key-type lock or padlock hasp. A table satisfactory for study of plans and two chairs shall be provided by CONTRACTOR. CONTRACTOR shall provide and pay for adequate electric lights, telephone service (not a pay phone), and adequate heat for the field office until authorized removal.

#### ARTICLE 42. UTILITIES

(a) All utilities, including but not limited to electricity, water, gas, and telephone used on work shall be furnished and paid for by CONTRACTOR. CONTRACTOR shall furnish and install necessary temporary distribution systems, including meters, if necessary, from distribution points to points on site where utility is necessary to carry on the work. When it is necessary to interrupt any existing utility service to make connections, a minimum of forty-eight (48) hours advance notice shall be given to the DISTRICT and ARCHITECT. Interruptions in utility services shall be of the shortest possible duration for the work at hand and shall be approved by the DISTRICT and the ARCHITECT. In the event any utility service is interrupted without the required forty-eight (48) hours notice, then CONTRACTOR shall be liable for all damage suffered by DISTRICT due to the interruption. Upon completion of work, CONTRACTOR shall remove all temporary distribution systems.

(b) CONTRACTOR may, with written permission of DISTRICT, use DISTRICT's existing utilities by making prearranged payments to DISTRICT for utilities used by CONTRACTOR for the Project.

#### ARTICLE 43. SANITARY FACILITIES

The CONTRACTOR shall provide sanitary temporary toilet facilities in no fewer numbers than required by law and such additional facilities as may be directed by the Inspector for the use of all workers. The toilet facilities shall be maintained in a sanitary condition at all

times and shall be left at the site until removal is directed by the Inspector. Use of toilet facilities in the work under construction shall not be permitted.

#### ARTICLE 44. CLEANING UP

CONTRACTOR at all times shall keep work site free from debris such as waste, rubbish, and excess materials and equipment caused by this work. CONTRACTOR shall not leave debris under, in, or about the work site, but shall promptly remove same. Upon completion of work, CONTRACTOR shall clean interior and exterior of building, including fixtures, equipment, walls, floors, ceilings, roofs, window sills and ledges, horizontal projections, and any areas where debris has collected. CONTRACTOR shall clean and polish all glass, plumbing fixtures, and finish hardware and similar finish surfaces and equipment and remove temporary fencing, barricades, planking, sanitary facilities and similar temporary facilities from site. If CONTRACTOR fails to clean up, the DISTRICT shall do so and the cost thereof shall be charged to the CONTRACTOR and deducted from any progress payment due.

#### ARTICLE 45. PATENTS, ROYALTIES, AND INDEMNITIES

The CONTRACTOR shall hold and save the DISTRICT and its governing board, officers, agents, and employees harmless from liability of any nature or kind, including cost and expense, for or on account of any patented or unpatented invention, process, article, or appliance manufactured or used in the performance of this Agreement, including its use by the DISTRICT, unless otherwise specifically provided in the Project Documents, and unless such liability arises from the sole negligence, or active negligence, or willful misconduct of the DISTRICT.

#### ARTICLE 46. GUARANTEE

(a) CONTRACTOR warrants that the work (which includes any equipment furnished by CONTRACTOR as part of the materials) shall: (a) be free from defects in workmanship and material; (b) be free from defects in any design performed by CONTRACTOR; (c) be new, and conform and perform to the requirements stated in the specifications and where detail requirements are not so stated, shall conform to applicable industry standards; and (d) be suitable for the use stated in the specifications.

(b) The warranty period for discovery of defective work shall commence on the date stamped on the Notice of Completion verifying County recordation and continue for the period set forth in the specifications or for one year if not so specified. If, during the warranty period, the work is not available for use due to defective work, such time of unavailability shall not be counted as part of the warranty period. The warranty period for corrected defective work shall continue for a duration equivalent to the original warranty period.

(c) District shall give CONTRACTOR prompt written notice after discovery of any defective work. CONTRACTOR shall correct any such defective work, as well as any

damage to any other part of the work resulting from such defective work, and provide repair, replacement, or reimbursement, at its sole expense, in a manner approved by the DISTRICT and with due diligence and dispatch as required to make the work ready for use by DISTRICT, ordinary wear and tear, unusual abuse or neglect excepted. Such corrections shall include, but not be limited to, any necessary adjustments, modifications, changes of design (unless of DISTRICT's design), removal, repair, replacement or reinstallation, and shall include all necessary parts, materials, tools, equipment, transportation charges and labor as may be necessary, and cost of removal and replacement of work shall be performed at a time and in such a manner so as to minimize the disruption to DISTRICT's use of the work.

(d) In the event of failure of CONTRACTOR or Surety to commence and pursue with diligence said repairs or replacements within ten (10) calendar days after being notified in writing, DISTRICT is hereby authorized to proceed to have defects repaired or replaced and made good at expense of CONTRACTOR and Surety who hereby agree to pay costs and charges therefore immediately on demand.

(e) If, in the opinion of the DISTRICT, defective work creates a dangerous condition or requires immediate correction or attention to prevent further loss to the DISTRICT or to prevent interruption of operations of the DISTRICT, the DISTRICT will attempt to give the written notice required by this Article. If the CONTRACTOR or Surety cannot be contacted or neither complies with the DISTRICT's requirements for correction within a reasonable time as determined by the DISTRICT, the DISTRICT may, notwithstanding the provisions of this Article, proceed to make such correction or provide such attention and the costs of such correction or attention shall be charged against the CONTRACTOR and Surety. Such action by the DISTRICT will not relieve the CONTRACTOR and Surety of the guarantees provided in this Article or elsewhere in the Project Documents.

(f) This Article does not in any way limit the guarantees on any items for which a longer guarantee is specified or on any items for which a manufacturer gives a guarantee for a longer period. CONTRACTOR shall furnish to DISTRICT all appropriate guarantee or warranty certificates upon completion of the Project or upon request by DISTRICT.

(g) All guarantees required under this Article shall be in writing on the Guarantee form included in the Project Documents.

(h) CONTRACTOR shall provide to DISTRICT instruction manuals for all items which require same.

(i) Nothing herein shall limit any other rights or remedies available to DISTRICT.

(j) The DISTRICT may collect its reasonable costs and attorneys' fees in any action to enforce this Article.

#### ARTICLE 47. DUTY TO PROVIDE FIT WORKERS

- (a) CONTRACTOR and subcontractors shall at all times enforce strict discipline and good order among their employees and shall not employ on work any unfit person or anyone not skilled in work assigned to such person. It shall be the responsibility of CONTRACTOR to ensure compliance with this Article.
- (b) Any person in the employ of the CONTRACTOR or subcontractors whom DISTRICT or ARCHITECT may deem incompetent, unfit, troublesome or otherwise undesirable shall be excluded from the work site and shall not again be employed on it except with written consent of DISTRICT.

#### ARTICLE 48. WAGE RATES, TRAVEL AND SUBSISTENCE

- (a) Pursuant to the provisions of Article 2 (commencing at Section 1770), Chapter 1, Part 7, Division 2 of the Labor Code, the governing board of DISTRICT has obtained the general prevailing rate of per diem wages and the general prevailing rate for holiday and overtime work in the locality in which this public work is to be performed for each craft, classification or type of worker needed for this Project from the Director of the Department of Industrial Relations ("Director.") These rates are on file with the Clerk of the DISTRICT's governing board and copies will be made available to any interested party on request. CONTRACTOR shall post a copy of such wage rates at the work site. Labor Code Section 1773.2. The rates are available on the Internet at [www.dir.ca.gov](http://www.dir.ca.gov) "Statistics & Research."
- (b) Holiday and overtime work, when permitted by law, shall be paid for at a rate of at least one and one-half times the above specified rate of per diem wages, unless otherwise specified. Holidays shall be defined in the Collective Bargaining Agreement applicable to each particular craft, classification or type of worker employed.
- (c) CONTRACTOR shall pay and shall cause to be paid each worker engaged in work on the Project not less than the general prevailing rate of per diem wages determined by the Director, regardless of any contractual relationship which may be alleged to exist between the CONTRACTOR or any subcontractor and such workers.
- (d) CONTRACTOR shall pay and shall cause to be paid to each worker needed to execute the work on the Project travel and subsistence payments, as such travel and subsistence payments are defined in the applicable collective bargaining agreements filed with the Department of Industrial Relations in accordance with Labor Code Section 1773.8.
- (e) If during the period this bid is required to remain open, the Director of Industrial Relations determines that there has been a change in any prevailing rate of per diem wages in the locality in which this public work is to be performed, such change shall not alter the wage rates in the Notice Calling for Bids or the contract subsequently awarded.
- (f) Pursuant to Labor Code Section 1775, CONTRACTOR shall as a penalty to the DISTRICT, forfeit fifty dollars (\$50) for each calendar day, or portion thereof, for each

worker paid less than the prevailing rate of per diem wages, determined by the Director, for such craft or classification in which such worker is employed for any public work done under the Agreement by CONTRACTOR or by any subcontractor under it. The amount of the penalty shall be determined by the Labor Commission and shall be based on consideration of the CONTRACTOR's mistake, inadvertence or neglect in failing to pay the correct prevailing rate of per diem wage, or the previous record of the CONTRACTOR in meeting his or her prevailing rate of per diem wage obligations, or the CONTRACTOR's willful failure to pay the correct prevailing rate of per diem wages. A mistake, inadvertence or neglect in failing to pay the correct prevailing rate of per diem wage is not excusable if the CONTRACTOR had knowledge of his or her obligations under this part. The difference between such prevailing rate of per diem wage and the amount paid to each worker for each calendar day or portion thereof for which each worker was paid less than the prevailing rate of per diem wage shall be paid to each worker by the CONTRACTOR.

(g) Any worker employed to perform work on the Project, which work is not covered by any craft or classification listed in the general prevailing rate of per diem wages determined by the Director shall be paid not less than the minimum rate of wages specified therein for the craft or classification which most nearly corresponds to work to be performed by them, and such minimum wage rate shall be retroactive to time of initial employment of such person in such craft or classification.

(h) Pursuant to Labor Code Section 1773.1, per diem wages are deemed to include employer payments for health and welfare, pension, vacation, travel time, and subsistence pay as provided for in Labor Code Section 1773.8.

(i) CONTRACTOR shall post at appropriate conspicuous points on the site of the Project, a schedule showing all determined minimum wage rates and all authorized deductions, if any, from unpaid wages actually earned.

#### ARTICLE 49. HOURS OF WORK

(a) As provided in Article 3, (commencing at Section 1810), Chapter 1, Part 7, Division 2 of the Labor Code, eight (8) hours of labor shall constitute a legal day's work. The time of service of any worker employed at any time by the CONTRACTOR or by any subcontractor on any subcontract under this Agreement upon the work or upon any part of the work contemplated by this Agreement shall be limited and restricted by the Agreement to eight (8) hours per day, and forty (40) hours during any one week, except as hereinafter provided. Notwithstanding the provisions hereinabove set forth, work performed by employees of CONTRACTOR in excess of eight (8) hours per day and forty (40) hours during any one week, shall be permitted upon this public work upon compensation for all hours worked in excess of eight (8) hours per day at not less than one and one-half times the basic rate of pay.

(b) The CONTRACTOR shall keep and shall cause each subcontractor to keep an accurate record showing the name of and actual hours worked each calendar day and each calendar week by each worker employed by CONTRACTOR in connection with the work



or any part of the work contemplated by this Agreement. The record shall be kept open at all reasonable hours to the inspection of the DISTRICT and to the Division of Labor Standards Enforcement, Department of Industrial Relations.

(c) Pursuant to Labor Code Section 1813, the CONTRACTOR shall pay to the DISTRICT a penalty of Twenty-Five Dollars (\$25) for each worker employed in the execution of this Contract by the CONTRACTOR or by any subcontractor for each calendar day during which such worker is required or permitted to work more than eight (8) hours in any one calendar day and 40 hours in any one calendar week in violation of the provisions of Article 3 (commencing at Section 1810), Chapter 1, Part 7, Division 2 of the Labor Code.

(d) Any work necessary to be performed after regular working hours, or on Sundays or other holidays shall be performed without additional expense to DISTRICT.

#### ARTICLE 50. PAYROLL RECORDS

(a) Pursuant to the provisions of Labor Code Section 1776, the CONTRACTOR shall keep and shall cause each subcontractor performing any portion of the work under this Agreement to keep an accurate payroll record, showing the name, address, social security number, work classification, straight time and overtime hours worked each day and week, and the actual per diem wages paid to each journeyman, apprentice, worker, or other employee employed by CONTRACTOR in connection with the work.

(b) The payroll records enumerated under subdivision (a) shall be certified and shall be available for inspection at all reasonable hours at the principal office of the CONTRACTOR on the following basis:

(1) A certified copy of an employee's payroll record shall be made available for inspection or furnished to the employee or his or her authorized representative on request.

(2) A certified copy of all payroll records enumerated in subdivision (a) shall be made available for inspection or furnished upon request to a representative of the DISTRICT, the Division of Labor Standards Enforcement, and the Division of Apprenticeship Standards of the Department of Industrial Relations.

(3) A certified copy of all payroll records enumerated in subdivision (a) shall be made available for inspection upon request by the public or copies thereof made; provided, however, that a request by the public shall be made through either the District, the Division of Apprenticeship Standards, or the Division of Labor Standards Enforcement. If the requested payroll records have not been provided pursuant to paragraph (2), the requesting party shall, prior to being provided the records, reimburse the costs of preparation by the CONTRACTOR, subcontractors, and the entity through which the request was made. The public shall not be given access to the records at the principal office of the CONTRACTOR.

(4) The form of certification shall be as follows:

I, \_\_\_\_\_ (Name-print), the undersigned, am \_\_\_\_\_ (position in business) with the authority to act for and on behalf of \_\_\_\_\_ (Name of business and/or CONTRACTOR), certify under penalty of perjury that the records or copies thereof submitted and consisting of \_\_\_\_\_ (description, number of pages) are the originals or true, full and correct copies of the originals which depict the payroll record(s) of the actual disbursements by way of cash, check, or whatever form to the individual or individuals named.

Dated: \_\_\_\_\_ Signature: \_\_\_\_\_

(c) Contractor shall file a certified copy of the payroll records enumerated in subdivision (a) with the entity that requested the records within ten (10) days after receipt of a written request. In the event that the CONTRACTOR fails to comply within the 10-day period, the CONTRACTOR shall, as a penalty to the DISTRICT, forfeit Twenty-Five Dollars (\$25) for each calendar day, or portion thereof, for each worker, until strict compliance is effectuated. Upon the request of the Division of Apprenticeship Standards or the Division of Labor Standards Enforcement, these penalties shall be withheld from progress payments then due.

(d) Any copy of payroll records made available for inspection as copies and furnished upon request to the public by the DISTRICT, the Division of Apprenticeship Standards, or the Division of Labor Standards Enforcement shall be marked or obliterated in such a manner as to prevent disclosure of an individual's name, address, and social security number. The name and address of the CONTRACTOR shall not be marked or obliterated.

(e) The CONTRACTOR shall inform the DISTRICT of the location of the payroll records enumerated under subdivision (a), including the street address, city and county, and shall, within five (5) working days, provide a written notice of a change of location and address.

(f) It shall be the responsibility of the CONTRACTOR to ensure compliance with the provisions of this Article 50 and the provisions of Labor Code Section 1776.

#### ARTICLE 51. APPRENTICES

(a) The CONTRACTOR acknowledges and agrees that, if this Agreement involves a dollar amount greater than or a number of working days greater than that specified in Labor Code Section 1777.5, this Agreement is governed by the provisions of Labor Code Section 1777.5. It shall be the responsibility of the CONTRACTOR to ensure compliance with this Article 51 and with Labor Code Section 1777.5 for all apprenticing occupations.

(b) Apprentices of any crafts or trades may be employed and, when required by Labor Code Section 1777.5, shall be employed provided they are properly registered in full compliance with the provisions of the Labor Code.

(c) Every such apprentice shall be paid the standard wage paid to apprentices under the regulations of the craft or trade at which he or she is employed, and shall be employed only at the work of the craft or trade to which he or she is registered.

(d) Only apprentices, as defined in Section 3077, who are in training under apprenticeship standards and written apprentice agreements under Chapter 4 (commencing at Section 3070), Division 3 of the Labor Code, are eligible to be employed on public works. The employment and training of each apprenticeship shall be in accordance with the provisions of the apprenticeship standards and apprentice agreements under which he or she is training.

(e) Pursuant to Labor Code Section 1777.5, the CONTRACTOR and any subcontractors employing workers in any apprenticeship craft or trade in performing any work under this Agreement shall employ apprentices in at least the ratio set forth in Section 1777.5 and apply to the applicable joint apprenticeship committee for a certificate approving the CONTRACTOR or subcontractor under the applicable apprenticeship standards for the employment and training of apprentices.

(f) Every contractor and subcontractor shall submit contract award information to the applicable joint apprenticeship committee which shall include an estimate of journeyman hours to be performed under the Agreement, the number of apprentices to be employed and the approximate dates the apprentices will be employed.

(g) If the CONTRACTOR or subcontractor willfully fails to comply with Labor Code Section 1777.5, then, upon a determination of noncompliance by the Chief of the Division of Apprenticeship Standards, the CONTRACTOR or subcontractor shall be subject to the penalties imposed under Labor Code Section 1777.7. Interpretation and enforcement of these provisions shall be in accordance with the rules and procedures of the California Apprenticeship Council.

(h) The CONTRACTOR and all subcontractors shall comply with Labor Code Section 1777.6, which section forbids certain discriminatory practices in the employment of apprentices.

(i) CONTRACTOR shall become fully acquainted with the law regarding apprentices prior to commencement of the work. Special attention is directed to Sections 1777.5, 1777.6, and 1777.7 of the Labor Code, and Title 8, California Code of Regulations, Section 200, et seq. Questions may be directed to the State Division of Apprenticeship Standards, 455 Golden Gate Avenue, 8<sup>th</sup> Floor, San Francisco, California 94102, (415) 703-4920.

ARTICLE 52. LABOR - FIRST AID

The CONTRACTOR shall maintain emergency first aid treatment for CONTRACTOR's workers on the Project which complies with the Federal Occupational Safety and Health Act of 1970 (29 U.S.C.A., Sec. 651, et seq.).

ARTICLE 53. PROTECTION OF PERSONS AND PROPERTY

(a) The CONTRACTOR shall be responsible for all damages to persons or property that occur as a result of its fault or negligence in connection with the prosecution of this Agreement and shall take all necessary measures and be responsible for the proper care and protection of all materials delivered and work performed until completion and final acceptance by the DISTRICT. CONTRACTOR shall provide such heat, covering, and enclosures as are necessary to protect all work, materials, equipment, appliances, and tools against damage by weather conditions. All work shall be solely at the CONTRACTOR's risk with the exception of damage to the work caused by "acts of God" as defined in Public Contract Code Section 7105.

(b) CONTRACTOR shall take, and require subcontractors to take, all necessary precautions for safety of workers and shall comply with all applicable federal, state, local and other safety laws, standards, orders, rules, regulations, and building codes to prevent accidents or injury to persons on, about, or adjacent to the work site and to provide a safe and healthful place of employment. CONTRACTOR shall furnish, erect and properly maintain at all times, as directed by DISTRICT or ARCHITECT or required by conditions and progress of work, all necessary safety devices, safeguards, construction canopies, signs audible devices for protection of the blind, safety rails, belts and nets, barriers, lights, and watchmen for protection of workers and the public and shall post danger signs warning against hazards created by such features in the course of construction. CONTRACTOR shall designate a responsible employee, whose duty shall be to post information regarding protection and obligations of workers and other notices required under occupational safety and health laws, to comply with reporting and other occupational safety requirements, and to protect the life, safety and health of workers. Name and position of person so designated shall be reported in writing to DISTRICT by CONTRACTOR. CONTRACTOR shall correct any violations of safety laws, standards, orders, rules, or regulations. Upon the issuance of a citation or notice of violation by the Division of Occupational Safety and Health, such violation shall be corrected immediately by the CONTRACTOR at CONTRACTOR's expense.

(c) In an emergency affecting safety of person or of work or of adjoining property, CONTRACTOR, without special instruction or authorization from ARCHITECT or DISTRICT, is hereby permitted to act, at its discretion, to prevent such threatened loss or injury; and CONTRACTOR shall so act if so authorized or instructed by Architect or DISTRICT. Any compensation claimed by CONTRACTOR on account of emergency work shall be determined by written agreement with the DISTRICT.

(d) CONTRACTOR shall take adequate precautions to protect existing roads, sidewalks, curbs, pavements, utilities, adjoining property and structures (including, without limitation, protection from settlement or loss of lateral support), and to avoid damage thereto, and repair any damage thereto caused by construction operations.

(e) CONTRACTOR shall (unless waived by the DISTRICT in writing):

(1) When performing new construction on existing sites, become informed and take into specific account the maturity of the students on the site; perform work which may interfere with school routine before or after school hours; enclose working area with a substantial barricade; not allow any unauthorized individuals on the site; require all workers on the Project to be conspicuously identified either by a firm logo on their clothing or prominent identification badge and arrange work to cause a minimum amount of inconvenience and danger to students and faculty in their regular school activities.

(2) Provide substantial barricades around any shrubs or trees indicated to be preserved.

(3) Deliver materials to building area over route designated by ARCHITECT.

(4) When directed by DISTRICT, take preventive measures to eliminate objectionable dust.

(5) Enforce all instructions of DISTRICT and ARCHITECT regarding signs, advertising, fires, and smoking and require that all workers comply with all regulations while on construction site.

(6) Take care to prevent disturbing or covering any survey markers, monuments, or other devices marking property boundaries or corners. If such markers are disturbed by accident, they shall be replaced by an approved civil engineer at no cost to the DISTRICT.

#### ARTICLE 54. NON-DISCRIMINATION

In the performance of the terms of this Agreement, CONTRACTOR agrees that it will not engage in nor permit such subcontractor as it may employ to engage in unlawful discrimination in employment of persons because of the race, religious creed, color, national origin, ancestry, physical handicap, medical condition, marital status, age or sex of such persons.

#### ARTICLE 55. SCHEDULE OF VALUES AND PERIODICAL ESTIMATES

(a) CONTRACTOR shall furnish on form(s) approved by DISTRICT:

(1) Within ten (10) calendar days of award of contract a detailed schedule of values giving complete breakdown of contract price for each component of the Project or site which shall include all subcontractor/supplier agreements showing dollar amounts of these agreements to justify the schedule of values; and

(2) A periodical itemized estimate of work done for purpose of making partial payments thereon. Change order work shall be clearly identified on a separate schedule of values.

(3) Within ten (10) calendar days of request of DISTRICT, a schedule of estimated monthly payments which shall be due CONTRACTOR under the Agreement.

(b) Values employed in making up any of these schedules are subject to the ARCHITECT's written approval and will be used only for determining basis of partial payments and will not be considered as fixing a basis for additions to or deductions from contract price.

#### ARTICLE 56. CONTRACTOR CLAIMS

If the CONTRACTOR shall claim compensation for any damage sustained by reason of the acts of the DISTRICT or its agents, CONTRACTOR shall, within five (5) calendar days after sustaining of such damage, make to the ARCHITECT a written statement of the damage sustained. On or before the 15th day of the month succeeding that in which such damage shall have been sustained the CONTRACTOR shall file with the DISTRICT an itemized statement of the details and amount of such damage, and unless such statement shall be made as thus required, CONTRACTOR's claims for compensation shall be forfeited and invalidated and it shall not be entitled to consideration for payment on account of any such damage.

#### ARTICLE 57. DISPUTES - ARCHITECT'S DECISIONS

(a) The ARCHITECT shall, within a reasonable time, make decisions on all matters relating to the CONTRACTOR's execution and progress of the work. The decisions of the ARCHITECT shall not be binding, but shall be advisory only on the CONTRACTOR for the purpose of CONTRACTOR's obligation to proceed with the work.

(b) Except for tort claims, all claims by the CONTRACTOR for a time extension, payment of money or damages arising from work done by, or on behalf of, the CONTRACTOR pursuant to the Agreement and payment of which is not otherwise expressly provided for or the claimant is not otherwise entitled to, or as to the amount of payment which is disputed by the DISTRICT of Three Hundred Seventy Five Thousand Dollars (\$375,000) or less shall be subject to the settlement procedures set forth in Public Contract Code Section 20104, et seq. which provisions are incorporated herein by reference.

(c) In the event of a dispute between the parties as to performance of the work, the interpretation of this Agreement or payment or nonpayment for work performed or not performed, the parties shall attempt to resolve the dispute. Pending resolution of the dispute, CONTRACTOR agrees to continue the work diligently to completion. If the dispute is not resolved, CONTRACTOR agrees it will neither rescind the Agreement nor stop the progress of the work, but CONTRACTOR's sole remedy shall be to submit such controversy to determination by a court of the State of California, in Orange County, having competent jurisdiction of the dispute, after the Project has been completed, and not before.

#### ARTICLE 58. PAYMENTS

(a) Unless otherwise specified in writing, each month within thirty (30) days after receipt by the DISTRICT of the monthly progress schedule and an undisputed, properly submitted payment request from CONTRACTOR which has been certified for payment by the Architect, there shall be paid to CONTRACTOR a sum equal to ninety-five percent (95%) of value of work performed and of materials delivered to the jobsite and inspected and approved by the inspector of record and subject to or under the control of the DISTRICT and unused up to the last day of the previous month, less aggregate previous payments. Public Contract Code Section 20104.50 Monthly payments shall be made only on the basis of monthly estimates which shall be prepared by CONTRACTOR on a form approved by DISTRICT and filed before the fifth day of the month during which payment is to be made. Work completed as estimated shall be an estimate only and no inaccuracy or error in said estimate shall operate to release CONTRACTOR or Surety from any damages arising from such work or from enforcing each and every provision of this Agreement, and DISTRICT shall have the right subsequently to correct any error made in any estimate for payment. CONTRACTOR SHALL NOT BE ENTITLED TO HAVE ANY PAYMENT ESTIMATES PROCESSED OR BE ENTITLED TO HAVE ANY PAYMENT FOR WORK PERFORMED SO LONG AS ANY LAWFUL OR PROPER DIRECTION CONCERNING WORK, OR ANY PORTION THEREOF, GIVEN BY THE DISTRICT OR ARCHITECT SHALL REMAIN UNCOMPLIED WITH BY THE CONTRACTOR. CONTRACTOR AGREES TO THE FIVE PERCENT (5%) RETENTION ON ALL PROGRESS PAYMENTS. Public Contract Code Section 9203.

(b) DISTRICT has discretion to require from the CONTRACTOR any of the following information with the application for payment: (i) certified payroll covering the period of the prior application for payment; (ii) unconditional waivers and releases from all subcontractors/suppliers for which payment was requested under the prior application for payment; and/or (iii) receipts or bills of sale for any items. CONTRACTOR agrees that payment may be contingent upon District receiving any one or more of these documents.

(c) Before payment is made hereunder, a certificate in writing shall be obtained from the ARCHITECT stating that the work for which the payment is demanded has been performed in accordance with the terms of the Project Documents and that the amount stated in the certificate is due under the terms of the Project Documents, which certificate shall be attached to and made a part of the claim made and filed with the DISTRICT,

provided that if the ARCHITECT shall, within three (3) days after written demand therefore, fail to deliver such certificate to the DISTRICT, the CONTRACTOR may file its claim with the DISTRICT without said certificate, but together with such claim shall be filed a statement that demand was made for such certificate and that the same was refused. Thereupon, the DISTRICT will either allow said claim as presented or shall, by an order entered on the minutes of said DISTRICT state the reasons for refusing to allow said claim. It is understood, moreover, that the certificate of the ARCHITECT shall not be conclusive upon the DISTRICT, but advisory only.

(d) Upon receipt of CONTRACTOR's payment request, DISTRICT shall review the payment request as soon as practicable after receipt for the purpose of determining that the payment request is proper. Any payment request determined not to be proper shall be returned to the CONTRACTOR as soon as practicable but not later than seven (7) days after receipt and shall be accompanied by a document setting forth in writing the reasons(s) why the payment request was not proper. Public Contract Code Section 20104.50

(e) NO PAYMENT BY DISTRICT HEREUNDER SHALL BE INTERPRETED SO AS TO IMPLY THAT DISTRICT HAS INSPECTED, APPROVED, OR ACCEPTED ANY PART OF THE WORK.

(f) Unless otherwise provided, on or before making request for final payment of the undisputed amount due under the Agreement, CONTRACTOR shall submit to DISTRICT, in writing a summary of all claims for compensation under or arising out of this Agreement which were timely filed. The acceptance by CONTRACTOR of the payment of the final amount shall constitute a waiver of all claims against DISTRICT under or arising out of this Agreement, except those previously made, in a timely manner and in writing, and identified by CONTRACTOR as unsettled at the time of CONTRACTOR's final request for payment.

(g) CONTRACTOR shall pay each of its subcontractors from whom retention has been withheld each subcontractor's share of the retention received within seven (7) days from the time that all or any portion of the retention are received by the CONTRACTOR subject to any limitations set forth in Public Contract Code Section 7107(e).

(h) The final payment of the five percent (5%) retention of the value of the work done under this Agreement, if unencumbered, shall be made thirty-five (35) days after recording by the DISTRICT of the Notice of Completion at the County Recorder's Office. APPROVAL OF COMPLETION OF THE PROJECT WILL BE MADE ONLY BY ACTION OF THE GOVERNING BOARD OF DISTRICT. Public Contract Code Section 7107.

#### ARTICLE 59. CHANGES AND EXTRA WORK

(a) DISTRICT may, as provided by law and without affecting the validity of this Agreement, order changes, modifications, deletions and extra work by issuance of written change orders from time to time during the progress of the Project, contract sum being



adjusted accordingly. All such work shall be executed under conditions of the original Agreement except that any extension of time caused thereby shall be adjusted at time of ordering such change. DISTRICT has discretion to order changes on a "time and material" basis with adjustments to time made after CONTRACTOR has justified through documentation the impact on the critical path of the Project.

(b) Notwithstanding any other provision in the Project Documents, the adjustment in the contract sum, if any, and the adjustment in the contract time, if any, set out in a change order shall constitute the entire compensation and/or adjustment in the contract time due CONTRACTOR arising out of the change in the work covered by the change order unless otherwise provided in the change order. The amount of the compensation due CONTRACTOR shall be calculated pursuant to subparagraph (e) of this Article 59. The entire compensation shall not include any additional charges not set forth in subparagraph (e) and shall not include delay damages (due to processing of a change order, refusal to sign a change order) indirect, consequential, and incidental costs including any project management costs, extended home office and field office overhead, administrative costs and profit other than those amounts authorized under subparagraph (e) of this Article 59.

(c) In giving instructions, ARCHITECT shall have authority to make minor changes in work, not involving change in cost, and not inconsistent with purposes of the Project. The DISTRICT's Assistant Superintendent of Business Services may authorize changes in work involving a change in cost that does not exceed Fifteen Thousand Dollars \$15,000. Otherwise, except in an emergency endangering life or property, no extra work or change shall be made unless in pursuance of a written order from DISTRICT, authorized by action of the governing board, and no claim for addition to contract sum shall be valid unless so ordered.

(d) If the ARCHITECT determines that work required to be done constitutes extra work outside the scope of the Agreement, the ARCHITECT shall send a request for a detailed proposal to the CONTRACTOR. CONTRACTOR will respond with a detailed proposal within five (5) calendar days of receipt of the Request for Proposal which shall include a complete itemized cost breakdown of all labor and materials showing actual quantities, hours, unit prices, and the wage rates required for the change. If the change order involves a change in construction time, a request for the time change shall accompany the change order cost breakdown. All such requests for time shall be specified by CONTRACTOR as either "work days" or "calendar days." Any request for time received with only the designation of "days" shall be considered calendar days. The term "work days" as used in this paragraph shall mean Monday through Friday, excluding Saturdays, Sundays and federal/State of California observed holidays. If the work is to be performed by a subcontractor, CONTRACTOR must include a bid from the subcontractor containing the same detailed information as required for CONTRACTOR. No extensions of time will be granted for change orders that, in the opinion of the ARCHITECT, do not affect the critical path of the Project.

(e) Value of any such extra work, change, or deduction shall be determined at the discretion of DISTRICT in one or more of the following ways:

(1) By mutual written acceptance of a lump sum proposal from CONTRACTOR properly itemized and supported by sufficient substantiating data to permit evaluation by DISTRICT and ARCHITECT.

(2) By unit prices contained in CONTRACTOR's original bid and incorporated in the Project Documents or fixed by subsequent agreement between DISTRICT and CONTRACTOR.

(3) By cost of material and labor and percentage for overhead and profit ("time and material"). If the value is determined by this method the following requirements shall apply:

(A) Daily Reports by Contractor.

(i) General. At the close of each working day, the CONTRACTOR shall submit a daily report to the ARCHITECT and the Inspector, on forms approved by the DISTRICT, together with applicable delivery tickets, listing all labor, materials, and equipment involved for that day, and for other services and expenditures when authorized concerning extra work items. An attempt shall be made to reconcile the report daily, and it shall be signed by the ARCHITECT and the CONTRACTOR. In the event of disagreement, pertinent notes shall be entered by each party to explain points which cannot be resolved immediately. Each party shall retain a signed copy of the report. Reports by Subcontractors or others shall be submitted through the CONTRACTOR.

(ii) Labor. The report shall show names of workers, classifications, and hours worked and hourly rate. Project Superintendent expenses are not allowed.

(iii) Materials. The report shall describe and list quantities of materials used and unit cost.

(iv) Equipment. The report shall show type of equipment, size, identification number, and hours of operation, including loading and transportation, if applicable, and hourly/daily cost.

(v) Other Services and Expenditures. Other services and expenditures shall be described in such detail as the DISTRICT may require.

(B) Basis for Establishing Costs

(i) Labor. The costs of labor will be the actual cost for wages prevailing locally for each craft classification or type of workers at the time the extra work is done, plus employer payments of payroll taxes and insurance, health and welfare, pension, vacation, apprenticeship funds, and other direct costs

resulting from federal, state or local laws, as well as assessments or benefits required by lawful collective bargaining agreements. The use of labor classification which would increase the extra work cost will not be permitted unless the CONTRACTOR establishes the necessity for such additional costs. Labor costs for equipment operators and helpers shall be reported only when such costs are not included in the invoice for equipment rental.

(ii) Materials. The cost of materials reported shall be at invoice or lowest current price at which such materials are locally available and delivered to the work site in the quantities involved, plus sales tax, freight and delivery. The DISTRICT reserves the right to approve materials and sources of supply, or to supply materials to the CONTRACTOR if necessary for the progress of the work. No markup shall be applied to any material provided by the DISTRICT.

(iii) Tool and Equipment Rental. No payment will be made for the use of tools which have a replacement value of \$100 or less or where an invoice is not provided.

Regardless of ownership, the rates to be used in determining equipment rental costs shall not exceed listed rates prevailing locally at equipment rental source, or distributors, at the time the work is performed. The rental rates paid shall include the cost of fuel, oil, lubrication, supplies, small tools, necessary attachments, repairs and maintenance of any kind, depreciation, storage, insurance, and all incidentals. Necessary loading and transportation costs for equipment used on the extra work shall be included. If equipment is used intermittently and, when not in use, could be returned to its rental source at less expense to the DISTRICT than holding it at the work site, it shall be returned, unless the CONTRACTOR elects to keep it at the work site at no expense to the DISTRICT.

All equipment shall be acceptable to the ARCHITECT, in good working condition, and suitable for the purpose for which it is to be used. Manufacturer's ratings and manufacturer's approved modifications shall be used to classify equipment and it shall be powered by a unit of at least the minimum rating recommended by the manufacturer.

(iv) Other Items. The DISTRICT may authorize other items which may be required on the extra work. Such items include labor, services, material and equipment which are different in their nature from those required by the work and which are of a type not ordinarily available from the CONTRACTOR or any of the subcontractors. Invoices covering all such items in detail shall be submitted with the request for payment.

(v) Invoices. Vendors' invoices for material, equipment rental, and other expenditures, shall be submitted with the request for payment. If the request for payment is not substantiated by invoices or other documentation, the DISTRICT may establish the cost of the item involved at the lowest price which was current at the time of the report.

(C) The following form shall be used as applicable by the DISTRICT and CONTRACTOR to communicate proposed additions and deductions to the Agreement.

	<u>EXTRA</u>	<u>CREDIT</u>
i. Material/Equipment (attach itemized quantity and unit cost plus sales tax)	_____	_____
ii. Labor (attach itemized hours and rates)	_____	_____
iii. Subtotal	_____	_____
iv. If subcontractor performed work, add Subcontractor's overhead and profit to portions performed by it, not to exceed 15% of Item iii. above	_____	_____
v. Subtotal	_____	_____
vi. General Contractor's Overhead and Profit, not to exceed 15% of Item v if Contractor performed the work. If subcontractor performed the work, not to exceed 5% of Item v. Of portions performed by Contractor and subcontractors, portions performed by Contractor shall not exceed 15% of Item V, and portions performed by Subcontractor shall not exceed 5% of Item v.	_____	_____
vii. Subtotal	_____	_____
viii. Bond and Liability Insurance Premium, if in fact additional bonds or insurance were actually purchased, not to exceed 1% of		

Item vii. \_\_\_\_\_

ix. Total \_\_\_\_\_

(4) IT IS EXPRESSLY UNDERSTOOD THAT THE VALUE OF SUCH EXTRA WORK OR CHANGES, AS DETERMINED BY ANY OF THE AFOREMENTIONED METHODS, EXPRESSLY INCLUDES ANY AND ALL OF CONTRACTOR'S COSTS AND EXPENSES, BOTH DIRECT AND INDIRECT, RESULTING FROM ADDITIONAL TIME REQUIRED ON THE PROJECT, OR RESULTING FROM DELAYS TO THE PROJECT. ANY COSTS OR EXPENSES NOT INCLUDED ARE DEEMED WAIVED. FOR PURPOSES OF DETERMINING THE COST, IF ANY, OF ANY EXTRA WORK, CHANGE, ADDITION OR OMISSION HEREUNDER, ALL TRADE DISCOUNTS, REBATES, REFUNDS, AND ALL RETURNS FROM THE SALE OF SURPLUS MATERIALS AND EQUIPMENT SHALL ACCRUE AND BE CREDITED TO CONTRACTOR, AND CONTRACTOR SHALL ENSURE THAT SUCH DISCOUNTS, REBATES, REFUNDS, AND RETURNS MAY BE SECURED, AND THE AMOUNT THEREOF SHALL BE ALLOWED AS A REDUCTION OF CONTRACTOR'S COST IN DETERMINING THE ACTUAL COST OF CONSTRUCTION FOR PURPOSES OF ANY EXTRA WORK, CHANGE, ADDITION OR OMISSIONS IN THE WORK AS PROVIDED HEREIN.

(f) If the CONTRACTOR should claim that any instruction, request, drawing, specification, action, condition, omission, default, or other situation obligates the DISTRICT to pay additional compensation to CONTRACTOR or to grant an extension of time, or constitutes a waiver of any provision in the Agreement, CONTRACTOR shall notify the DISTRICT, in writing, of such claim within five (5) calendar days from the date CONTRACTOR has actual or constructive notice of the factual basis supporting the claim. The notice shall state the factual bases for the claim and cite in detail the Project Documents (including plans and specifications) upon which the claim is based. The CONTRACTOR's failure to notify the DISTRICT within such five (5) day period shall be deemed a waiver and relinquishment of such a claim. If such notice be given within the specified time, the procedure for its consideration shall be as stated above in these General Conditions.

(g) “PROHIBITED USAGE OF CONTRACTOR QUALIFYING LANGUAGE STAMPS ON DISTRICT DRAWINGS OR CONTRACT FORMS.” Contractor shall not countersign or endorse any form, drawing, change order, contract or other documents with any conditions not mutually agreed to in advance by the DISTRICT and the CONTRACTOR. Endorsement of a contract, change order, specification, drawing or form with the following: “This change order is being executed without waiver of the right to seek additional compensation for such services,” shall be of no legal force or effect.

## ARTICLE 60. COMPLETION

(a) The DISTRICT shall accept completion of the Project and have the Notice of Completion recorded within ten (10) days of acceptance of completion of the Project when the entire work including punch list items shall have been completed to the satisfaction of the DISTRICT. Civil Code Section 3093. The work may only be accepted as complete by action of the DISTRICT's Governing Board.

(b) However, the DISTRICT, at its sole option, may accept completion of the Project and have the Notice of Completion recorded when the entire work including individual portions of the work shall have been completed to the satisfaction of the DISTRICT, except for minor corrective items, as distinguished from incomplete items.

(c) A final walk through of the Project to determine completion and to record the Notice of Completion shall occur only upon a valid claim by CONTRACTOR that the Project is complete except for minor corrective items. Any erroneous claims of completion by CONTRACTOR resulting in a premature walk through shall be at CONTRACTOR's sole cost and expense and DISTRICT shall make adjustments to the contract price by reducing the amount thereof to pay for any costs incurred by the DISTRICT due to the erroneous claims by the CONTRACTOR that the Project is complete. Minor corrective items shall be identified in the final walk through of the Project.

(d) If the CONTRACTOR fails to complete the minor corrective items prior to the expiration of the thirty-five (35) day period immediately following recording of the Notice of Completion, the DISTRICT shall withhold from the final payment an amount equal to one hundred fifty percent (150%), as determined by the DISTRICT, of the amount of each item until such time as the item is completed. Public Contract Code Section 7107. At the end of such 35-day period, if there are items remaining to be corrected, the DISTRICT may elect to proceed as provided in Article 61(b) entitled "Adjustments to Contract Price."

## ARTICLE 61. ADJUSTMENTS TO CONTRACT PRICE

(a) If CONTRACTOR defaults or neglects to carry out the work in accordance with the Project Documents or fails to perform any provision thereof, DISTRICT may, after ten (10) days written notice to the CONTRACTOR and without prejudice to any other remedy it may have, make good such deficiencies.

(b) The DISTRICT shall adjust the total contract price by reducing the amount thereof by the cost of making good such deficiencies. If DISTRICT deems it inexpedient to correct work not done in accordance with the Project Documents, an equitable reduction in the contract price shall be made therefore.

## ARTICLE 62. CORRECTION OF WORK

(a) CONTRACTOR shall promptly remove all work identified by DISTRICT as failing to conform to the Project Documents, whether incorporated or not.

CONTRACTOR shall promptly replace and re-execute its own work to comply with Project Documents without additional expense to DISTRICT and shall bear the expense of making good all work of other contractors destroyed or damaged by such removal or replacement.

(b) If CONTRACTOR does not remove such work within a reasonable time, fixed by written notice, DISTRICT may remove it and may store the material at CONTRACTOR's expense. If CONTRACTOR does not pay expenses of such removal within ten (10) days' time thereafter, DISTRICT may, upon ten (10) days written notice, sell such materials at auction or at private sale and shall account for net proceeds thereof, after deducting all costs and expenses that should have been borne by CONTRACTOR.

#### ARTICLE 63. EXTENSION OF TIME - LIQUIDATED DAMAGES

(a) The CONTRACTOR and DISTRICT hereby agree that the exact amount of damages for failure to complete the work within the time specified is extremely difficult or impossible to determine. CONTRACTOR shall be assessed liquidated damages for each and every day the work required under the Project Documents remains unfinished past the time for completion, as set forth in the Agreement, and any extensions of time granted by the DISTRICT to the CONTRACTOR under the terms of the Project Documents. The CONTRACTOR will pay to the DISTRICT or DISTRICT may retain from amounts otherwise payable to the CONTRACTOR, said amount for each day after failure to meet the requirements of the contract completion as scheduled in the Agreement. Government Code Section 53069.85 for purposes of this article, the work shall be considered "complete" in accordance with the provisions of Article 60, "COMPLETION", except that the work may be considered complete without formal acceptance by the DISTRICT Governing Board so long as the Governing Board, at its next regularly scheduled meeting, accepts the work.

(b) CONTRACTOR shall not be charged for liquidated damages, as set forth above, because of any delays in completion of work which are not the fault or negligence of CONTRACTOR, including but not restricted to acts of God. CONTRACTOR shall within ten (10) days of beginning of any such delay, notify DISTRICT in writing of causes of delay. CONTRACTOR shall provide documentation and justification to substantiate the delay and its relation to the Project's critical path. DISTRICT shall ascertain the facts and extent of delay and grant extension of time for completing work when, in its judgment, the findings of fact justify such an extension. The DISTRICT's finding of fact thereon shall be final and conclusive on the parties hereto. Extension of time shall apply only to that portion of work affected by the delay, and shall not apply to other portions of work not so affected.

#### ARTICLE 64. PAYMENTS WITHHELD

(a) In addition to amount which DISTRICT may retain under Article entitled "COMPLETION" and Article entitled "PAYMENTS," DISTRICT may withhold a

sufficient amount or amounts of any payment or payments otherwise due to CONTRACTOR, as in its judgment may be necessary to cover:

- (1) Payments which may be past due and payable for just claims against CONTRACTOR or any subcontractors, or against and about the performance of work on the Project, including, without limitation, payments made pursuant to the Article entitled "PAYMENTS BY CONTRACTOR."
- (2) The cost of defective work which CONTRACTOR has not remedied.
- (3) Liquidated damages assessed against CONTRACTOR.
- (4) Penalties for violation of labor laws.
- (5) The cost of materials ordered by the DISTRICT pursuant to Article 33 entitled "MATERIALS AND WORK."
- (6) The cost of completion of this Agreement if there exists a reasonable doubt that this Agreement can be completed for the balance then unpaid to CONTRACTOR.
- (7) Damage to DISTRICT, another contractor, or subcontractor.
- (8) Site clean-up as provided in Article 44 entitled "CLEANING UP."
- (9) Payments to indemnify, defend, or hold harmless the DISTRICT.
- (10) Any payments due to the District including but not limited to payments for failed tests, utilities or imperfections.
- (11) Extra services for ARCHITECT.
- (12) Extra services for the INSPECTOR including but not limited to reinspection required due to CONTRACTOR's failed tests or installation of unapproved or defective materials and CONTRACTOR's requests for inspection and CONTRACTOR's failure to attend the inspection.
- (13) Failure of CONTRACTOR to submit on a timely basis, proper and sufficient documentation required by the Project Documents, including without limitation, monthly progress schedules, shop drawings, submittal schedules, schedule of values, product data and samples, proposed product lists, executed change orders and verified reports.
- (14) Any other obligation(s) of the DISTRICT which the DISTRICT is authorized and/or compelled by law to perform.



(b) If the above grounds are in the opinion of the DISTRICT removed by or at the expense of CONTRACTOR, payment shall be made for amounts withheld because of them.

(c) DISTRICT may apply such withheld amount or amounts to payment of such claims or obligations at its discretion. In so doing, DISTRICT shall make such payments on behalf of CONTRACTOR. If any payment is so made by DISTRICT, then such amount shall be considered as a payment made under contract by DISTRICT to CONTRACTOR and DISTRICT shall not be liable to CONTRACTOR for such payments made in good faith. Such payments may be made without prior judicial determination of claim or obligations. DISTRICT will render CONTRACTOR an accounting of such funds disbursed on behalf of CONTRACTOR.

(d) As an alternative to payment of such claims or obligations, DISTRICT, in its sole discretion, may reduce the total contract price as provided in Article 61 entitled "ADJUSTMENTS TO CONTRACT PRICE."

#### ARTICLE 65. TAXES

(a) CONTRACTOR will pay all applicable federal, state and local taxes on all materials, labor, or services furnished by it, and all taxes arising out of its operations under the Project Documents.

(b) If under federal excise tax law any transaction hereunder constitutes a sale on which a federal excise tax is imposed and the sale is exempt from such excise tax because it is a sale to a state or local government for its exclusive use, the DISTRICT, upon request, will execute documents necessary to show (1) that the DISTRICT is a political subdivision of the State for the purposes of such exemption and (2) that the sale is for the exclusive use of the DISTRICT. No excise tax for such materials shall be included in any bid price.

#### ARTICLE 66. NO ASSIGNMENT

The CONTRACTOR shall not assign, transfer, convey, sublet or otherwise dispose of this Agreement or of its rights, title or interest in or to the same or any part thereof. If the CONTRACTOR shall assign, transfer, convey, sublet or otherwise dispose of the Agreement or its right, title or interest therein, or any part thereof, such attempted or purported assignment, transfer, conveyance, sublease or other disposition shall be null, void and of no legal effect whatsoever; and the Agreement may, at the option of the DISTRICT, be terminated, revoked and annulled, and the DISTRICT shall thereupon be relieved and discharged from any and all liability and obligations growing out of the same to the CONTRACTOR, and to its purported assignee or transferee.

#### ARTICLE 67. NOTICE

Any notice from one party to the other or otherwise under the Agreement shall be in writing and shall be dated and signed by party giving such notice or by a duly authorized

representative of such party. Any such notice shall not be effective for any purpose whatsoever unless served in one of the following manners:

- (1) If notice is given to DISTRICT, by personal delivery thereof to DISTRICT, or by depositing same in United States mail, enclosed in a sealed envelope addressed to DISTRICT, and sent by registered or certified mail with postage prepaid;
- (2) If notice is given to CONTRACTOR, by personal delivery thereof to said CONTRACTOR, or to CONTRACTOR's superintendent at site of Project, or by depositing same in United States mail, enclosed in a sealed envelope addressed to said CONTRACTOR at its regular place of business or at such address as may have been established for the conduct of work under this Agreement, and sent by registered or certified mail with postage prepaid;
- (3) If notice is given to surety or other persons, by personal delivery to such surety or other person, or by depositing same in United States mail, enclosed in a sealed envelope, addressed to such surety or person at the address of such surety or person last communicated by surety or other person to party giving notice, and sent by registered or certified mail with postage prepaid.

#### ARTICLE 68. NO WAIVER

The failure of the DISTRICT in any one or more instances to insist upon strict performance of any of the terms of this Agreement or to exercise any option herein conferred shall not be construed as a waiver or relinquishment to any extent of the right to assert or rely upon any such terms or option on any future occasion.

#### ARTICLE 69. NON-UTILIZATION OF ASBESTOS MATERIAL

- (a) The CONTRACTOR will be required to execute and submit the Certificate Regarding Non-Asbestos Containing Materials.
- (b) Should asbestos containing materials be installed by the CONTRACTOR in violation of this certification, or if removal of asbestos containing materials is part of the Project, decontaminations and removals will meet the following criteria:
  - (1) Decontamination and removal of work found to contain asbestos or work installed with asbestos containing equipment shall be done only under the supervision of a qualified consultant, knowledgeable in the field of asbestos abatement and accredited by the Environmental Protection Agency (EPA).
  - (2) The asbestos removal contractor shall be an EPA accredited contractor qualified in the removal of asbestos and shall be chosen and approved by the asbestos consultant who shall have sole discretion and final determination in this matter.

(3) The asbestos consultant shall be chosen and approved by the DISTRICT who shall have sole discretion and final determination in this matter.

(4) The work will not be accepted until asbestos contamination is reduced to levels deemed acceptable by the asbestos consultant.

(c) Cost of all asbestos removal, including, but not necessarily limited to the cost of the asbestos removal contractor, the cost of the asbestos consultant, analytical and laboratory fees, time delays and additional costs as may be incurred by the DISTRICT shall be borne entirely by the CONTRACTOR.

(d) Hold Harmless: Interface of work for the Project with work containing asbestos shall be executed by the CONTRACTOR at his/her risk and at his/her discretion with full knowledge of the currently accepted standards, hazards, risks and liabilities associated with asbestos work and asbestos containing products. By execution of the Agreement, the CONTRACTOR acknowledges the above and agrees to hold harmless the DISTRICT, its Governing Board, employees, agents, and ARCHITECT and assigns for all asbestos liability which may be associated with this work. The CONTRACTOR further agrees to instruct his/her employees with respect to the above mentioned standards, hazards, risks and liabilities.

#### ARTICLE 70. LEAD

Pursuant to the Lead-Safe Schools Protection Act (Education Code Sections 32240, et seq.) and other applicable law, the CONTRACTOR shall not use lead-based paint, lead plumbing and solders, or other potential sources of lead contamination in the construction of any new school facility or the modernization or renovation of any existing school facility.

#### ARTICLE 71. CRIMINAL RECORDS CHECK

Education Code Section 45125.1 provides that if the employees of any entity that has a contract with a school district may have any contact with pupils, those employees shall submit or have submitted their fingerprints in a manner authorized by the Department of Justice together with a fee determined by the Department of Justice to be sufficient to reimburse the Department for its costs incurred in processing the application. The CONTRACTOR shall not permit an employee to come in contact with DISTRICT pupils until the Department of Justice has ascertained that the employee has not been convicted of a violent or serious felony. The CONTRACTOR shall certify in writing to the Governing Board of the DISTRICT that none of its employees who may come in contact with pupils have been convicted of a violent or serious felony. Criminal Records Check Certification by CONTRACTOR is included in the Project Documents.

## ARTICLE 72. DISABLED VETERAN BUSINESS ENTERPRISES

Each bidder must meet goals and requirements relating to three percent (3%) participation by Disabled Veteran Business Enterprises, established by the DISTRICT and the State Allocation Board (SAB), or make a good faith effort with respect thereto, in accordance with the DISTRICT's policies and procedures. CONTRACTOR may obtain information from the Office of Small Business Certification and Resources (OSBCR) at <http://www.dgs.ca.gov/osbcr> or (916) 323-5478. The CONTRACTOR shall be required to submit to the DISTRICT the DVBE Certification which is included in the Project Documents. Prior to, and as a condition precedent for final payment on the Project, the CONTRACTOR shall provide appropriate documentation to the DISTRICT so that the DISTRICT can assess its success at meeting the DVBE participation goal.

## ARTICLE 73. TOBACCO FREE POLICY

CONTRACTOR has been advised and is aware that DISTRICT has adopted a Board Policy which prohibits the use of tobacco products, including smokeless tobacco, anywhere on DISTRICT property. CONTRACTOR shall be responsible for the enforcement of DISTRICT's tobacco-free policy among all CONTRACTOR's employees and subcontractors while on DISTRICT property. CONTRACTOR understands and agrees that should any employee or subcontractor of CONTRACTOR violate the DISTRICT's Board Policy after having already been warned once for violating DISTRICT's tobacco-free policy, CONTRACTOR shall remove the individual for the duration of the Project. CONTRACTOR shall not be entitled to any additional compensation and/or time in completing the Project for such removal.

## ARTICLE 74. GOVERNING LAW

The laws of the State of California shall govern the Project and the Agreement.